



More than storage: system flexibility - FactBook

# Hydrogen-based energy conversion

A.T. Kearney Energy Transition Institute  
February 2014

# Compiled by the A.T. Kearney Energy Transition Institute

## Acknowledgements

A.T. Kearney Energy Transition Institute wishes to acknowledge for their review of this FactBook: Amgad Elgowainy, principal energy systems analyst at Argonne National Laboratory; Marcel Weeda, manager hydrogen transitions and infrastructure at Energy Research Center of the Netherlands; Alexander Körner, lead author of the Hydrogen Technology Roadmap of the International Energy Agency (IEA). Their review does not imply that they endorse this FactBook or agree with any specific statements herein. The Energy Transition Institute expresses its gratitude to Kamel Bennaceur, former Board Member of the Institute, for his guidance and support throughout the study, and also gratefully acknowledges individuals, companies, research centers and industry associations interviewed during the preparatory phase of the study. Finally, the Institute also wishes to thank the authors of this FactBook for their contribution: Benoît Decourt, Bruno Lajoie, Romain Debarre and Olivier Soupa.

## About the FactBook – Hydrogen-Based Energy Conversion

The FactBook provides an extensive technoeconomic analysis of the entire value chain, from power conversion to end-uses of hydrogen. The objective was to view the hydrogen industry through a technological prism, revealing barriers to progress and providing stakeholders – be they policy-makers, energy professionals, investors or students – with the tools needed to understand a complex and often misunderstood sector. In addition, the Energy Transition Institute summarizes and assesses nine business cases for hydrogen, based on academic literature and research.

## About the A.T. Kearney Energy Transition Institute

The A.T. Kearney Energy Transition Institute is a nonprofit organization. It provides leading insights on global trends in energy transition, technologies, and strategic implications for private sector businesses and public sector institutions. The Institute is dedicated to combining objective technological insights with economical perspectives to define the consequences and opportunities for decision makers in a rapidly changing energy landscape. The independence of the Institute fosters unbiased primary insights and the ability to co-create new ideas with interested sponsors and relevant stakeholders.

# Table of Contents

<b>Executive Summary</b> .....	<b>4</b>
<b>1. Making the case for hydrogen conversion: intermittency, flexibility &amp; energy storage</b> .....	<b>14</b>
1.1 The intermittency challenge.....	17
1.2 The need for flexibility.....	22
1.2 The new momentum of electricity storage.....	28
1.3 Making the case for hydrogen conversion solutions.....	36
<b>2. Techno-economic analysis of the value chain</b> .....	<b>45</b>
2.1 Electron-to hydrogen: water electrolysis.....	46
2.2 Hydrogen storage & transport.....	64
2.3 Hydrogen-to-electron.....	84
2.4 Hydrogen-to-gas.....	101
2.5 Hydrogen-to-liquid fuels.....	125
2.6 Hydrogen-to-mobility.....	136
2.7 Hydrogen-to-chemical.....	152
2.8 Integrated hydrogen projects.....	165
<b>3. Business cases</b> .....	<b>176</b>
3.1 Monetizing hydrogen conversion.....	177
3.2 Selected business cases.....	188
<b>4. Environmental impact, safety and social acceptance</b> .....	<b>226</b>
4.1 Environmental impact.....	229
4.2 Safety.....	236
4.3 Social acceptance.....	246
<b>5. Outlook</b> .....	<b>250</b>
<b>Appendix</b> .....	<b>263</b>

# The increasing share of wind and solar photovoltaic energy in the power mix is making the case for hydrogen-based energy conversion solutions

**The need for flexibility** - Since the 2000s, onshore wind and solar photovoltaic [PV] technologies have grown exponentially. While wind and solar PV still represent a limited proportion of the global power mix (around 7% of installed capacity and 3% of power generated), their share in some regions is significant and deployment is expected to continue at a strong pace.

Wind and solar PV are unique in the power-generation technology landscape because of the intermittent nature of their output. Their production is variable, largely uncontrollable and hard to predict, while the most favorable locations for generating variable renewables are often far from consumption centers. They make demand-supply matching more difficult since they increase the need for flexibility within the system, but do not themselves contribute significantly to flexibility.

Even if flexibility management can be optimized, for instance by refining the design of power systems, additional flexibility will be needed in the form of demand-side participation, better connections between markets, greater flexibility in baseload power supply and electricity storage.

**The new momentum of electricity storage** - Electricity storage is not new. In 2012, an estimated 128 GW of storage power capacity was installed around the world. However, 99% of that was pumped hydro storage [PHS]. All other technologies are at earlier stages of development and still have to demonstrate their commercial potential. However, not all electricity storage technologies are in direct competition with each other, as they may be designed to provide different types of storage service. For bulk-storage applications, there are three main options: PHS, compressed air energy storage [CAES], and hydrogen-based energy storage.

There are two reasons to store electricity: first, to provide back-up power for times when intermittent renewables are not producing energy; and second, to make use of surplus supply, reflected in low power prices or curtailments in wind power, both of which have occurred in various regions in recent years. Surplus is likely to be the major driver for bulk-storage technologies, since it results in low electricity costs.

The increasing use of wind and solar PV is bringing the potential and limitations of existing storage applications into sharp focus. Hydrogen-based storage technologies may be the best way of absorbing peaks in renewable electricity supply and avoiding the wastage of large quantities of renewable power, especially when natural sites for pumped hydro storage are not available or already occupied.

**Making the case for hydrogen-based energy solutions** - Hydrogen energy storage solutions are based on the electro-chemical conversion of electricity into a new energy carrier, hydrogen, by means of water electrolysis, in which water [H<sub>2</sub>O] is split by an electric current into its constituent elements, (di)-hydrogen [H<sub>2</sub>] and oxygen [O]. Exploiting hydrogen's versatility, chemical energy storage opens up alternatives to the usual approach to electricity storage.

First, time. Although the volumetric energy density of hydrogen is inferior to those of hydrocarbons, it is superior to those of other bulk-electricity-storage technologies. It is the only technology capable of compensating for several weeks of windless or cloudy conditions.

Second, location. Hydrogen-based technologies could reduce infrastructure investments required for integrating intermittent generators into the grid. Converting electricity produced from renewables into hydrogen allows existing infrastructure to be leveraged: power networks by locating storage facilities at congestion nodes to level the load; gas networks (in a process known as power-to-gas); and hydrogen transport options (e.g. pipelines, road transport on truck-trailers etc.).

Third, application. The versatility of hydrogen-based storage solutions, compared with other electricity-storage technologies, means they are not restricted to providing electricity back to the grid, using fuel cells or combustion turbines. Hydrogen can be used in its traditional markets, as an upgrader in refineries or as a commodity in many industrial processes. Hydrogen can also be used as transport fuel, directly, in fuel cell electric vehicles [FCEV], it can be blended with natural gas to fuel compressed natural gas vehicles and it can even be used as a feedstock for producing synthetic fuels. Finally, it can play an important role in decarbonizing end-uses of heat through power-to-gas concepts.

Why hydrogen-based energy storage? And why now? Energy systems must be considered as a whole. Within such a vision, hydrogen could play a central role as a bridge between the intermittent electricity provided by wind and solar energy and the dominant molecular energy system based on hydrocarbons. However, hydrogen technologies have yet to demonstrate their potential and overcome their efficiency, cost and safety challenges.

# Converting intermittent electricity into hydrogen by means of water electrolysis is the main economic and technological challenge for hydrogen-based electricity storage

**The missing link** - Cost-effective electrolysis is the missing link in the hydrogen-conversion value chain. Although continuous-load water electrolysis is a mature technology, the need for electrolysis systems to withstand variable loads requires significant flexibility and this has changed the game.

**Electrolysis: the momentum is with PEM technology** - The need for flexibility is making proton exchange membrane [PEM] technology a popular alternative to alkaline systems. The latter is currently the lower-cost option and the only practical solution for large systems, but it suffers from its limited ability to respond to load changes and from a complex design that offers limited cost-reduction potential.

Conversely, PEM is highly flexible and has a simple design. There will be considerable potential for cost reduction if the technology enters mass-production. The economics of PEM electrolysis would also benefit from a reduction in the amount of noble metal catalysts used. In addition, PEM cells can operate at higher current densities than alkaline cells and are, as a result, more compact; last, but not least, they can more easily supply self-pressurized hydrogen— limiting the need for hydrogen compression. Most manufacturers, including Siemens, Hydrogenics and ITM Power, are now betting heavily on PEM and the first megawatt systems have been completed in 2013.

High-temperature solid oxide electrolyzer cells [SOEC] are a groundbreaking technology, at the R&D stage. SOECs can theoretically achieve unrivaled efficiency due to their ability to recover heat to supply the energy needed for electrolysis. Combined with the absence of noble metal catalysts and their simple design, these advantages are expected to lower capital costs per unit of capacity. SOECs also enable regenerative electrolysis (*i.e.* electrolysis with the ability to run in reverse mode) and the co-electrolysis of carbon dioxide and water. However, they will not be viable in the near term because of the relatively rapid degradation rate of their membrane and to their limited ability to withstand variable loads.

**Hydrogen production cost and utilization rate** - Electrolyzers cannot yet compete with conventional H<sub>2</sub>-production processes, but their competitiveness may benefit from two features.

First, due to the modular nature of electrolyzer plants, the levelized cost of hydrogen [LCOH] is not significantly affected by plant size. Under prevailing market conditions and operated in baseload mode, decentralized production costs roughly 5% more than centralized production. If steam methane reforming [SMR] – the most common hydrogen-production technology – is being used to make hydrogen, then decentralized production costs twice as much as centralized production. Even though production by electrolysis is closer to competing with SMR in decentralized production, grid-connected electrolyzers are still generally unable to compete with SMR when operated continuously.

Second, discontinuous operation should reduce the LCOH by enabling the arbitrage of grid electricity price variations (using off-peak electricity prices where possible) and, more importantly, by generating revenues from power grid services (being rewarded for the ability to adjust electricity withdrawal upwards or downwards very quickly and on demand). At present, electricity price spreads on the spot markets are still too narrow to enable significant hydrogen-production cost reductions through price arbitrage. Indeed, the most important factor is how frequently low price events occur rather than how negative they can be at any one time.

**Capital cost decrease priority** - Improving efficiency has long been the priority of electrolyzer manufacturers, since electricity costs are the main component of hydrogen-production costs in continuous-load electrolysis. Significant improvements in the electrochemical performance of electrolyzers have been made; PEM and Alkaline can now attain efficiencies of 78%. The next priority, especially for PEM, is to lower manufacturing costs, which have a greater impact than efficiency on the LCOH, if the electrolyzer is operated highly discontinuously. In view of this, electrolyzers are entering a phase of development in which engineering and manufacturing will become the prevalent issues.

# The use of hydrogen storage and transport must be minimized in order to avoid cost and efficiency penalties incurred by initial conditioning

**The challenge of hydrogen conditioning** - Hydrogen storage and transport form the most mature segment of the chain, benefiting from the chemicals and petrochemicals industries' extensive experience of hydrogen utilization. The challenge is, first and foremost, economic. Due to hydrogen's very low volumetric energy density at ambient conditions, the volume of hydrogen gas produced by water electrolysis must be reduced in some way: compression, liquefaction (cooling to  $-253^{\circ}\text{C}$ ) or absorption into metal hydrides.

This initial conditioning step incurs energy losses of 5-15% in the case of compression (depending on pressure differentials), 25-45% during liquefaction, and 5-20% in the case of absorption into metal hydrides, varying according to heat-recycling capability. Conditioning also incurs additional capital costs. In order to minimize those costs, electrolyzers delivering self-pressurized hydrogen to end-user sites are likely to be the preferred option. Note that minimizing the handling costs of hydrogen is also of the main rationales behind power-to-gas.

**Hydrogen storage: pressurized tank as preferred option** - Even if its role is reduced, hydrogen storage will still be needed in most cases, at least to act as buffer along the value chain. The choice of storage type depends largely on the energy-capacity requirement and space constraints, but also on the desired operating cycling rate.

Pressurized tanks are likely to remain the main means of storing hydrogen. They are well suited to small- to mid-scale applications, safe thanks to years of experience, efficient and affordable, as long as the cycling rate is high. Underground storage in man-made salt caverns allows lower cycling rates and is the most competitive option for large-scale storage. However, bulk hydrogen storage seems unlikely to be needed in the near future and could suffer from limited geological availability; other than salt formations, reservoirs being considered for hydrogen storage are still at the early demonstration phase.

Liquefied hydrogen is, in many ways, ill-suited to electrolytic hydrogen storage. The large investment required for cryogenic facilities and the intensive use of energy in liquefaction are constraining the technology. However, since liquefied-hydrogen storage benefits from economies of scale and provides extremely pure hydrogen, it could play a role in the long-distance cryogenic transport of large quantities of hydrogen to refueling stations. Finally, metal hydrides may change the rules of the game for small-to-medium-scale applications in the medium term. Avoiding hydrogen compression or liquefaction is, in theory, very appealing. Yet the industry remains torn between optimism and caution when it comes to hydride storage. Its potential outside niche markets, where its safety and density are crucial advantages, remains to be proved.

**Hydrogen transport: distance, throughput and distribution criteria** - Transport requirements must be considered because the choice of conditioning and storage constrains the type of transport that can be used. The choice of transport depends on transport distance, on hydrogen throughput and on the distribution of end users.

Road transport enables distributed delivery. The transport of compressed hydrogen in tanks is limited to short distances and low throughputs. Liquid hydrogen transportation may only be viable for large quantities delivered over long distances to numerous locations, most likely refueling stations. Finally, pipelines can provide a low-cost option for point-to-point delivery of large volumes of hydrogen. However, they lack the flexibility of road vehicles for distributed delivery. Furthermore, pipe-laying incurs significant up-front costs, which, in view of current demand for hydrogen, will inhibit the expansion of hydrogen pipelines.

The final configuration of a hydrogen system could include a mix of solutions, such as decentralized electrolysis located on end-user sites, with centralized production centers as back-up or to adjust for fluctuating demand for road deliveries.

# Re-electrification is likely to come last in the merit order of end-uses of electrolytic hydrogen because of its very poor round-trip efficiency

**Fuel cells and combustion turbines** - Hydrogen can be re-electrified in a direct electrochemical process, using fuel cells, but also using conventional thermal combustion turbines. These processes do not compete for the same applications: fuel cells are much more suited to decentralized designs and prioritize reliability, autonomy and low-maintenance; turbines are more suited to large-scale centralized projects because of economies of scale. Both pathways pose only moderate technical issues.

Fuel cells have long been under development, driven by the promise of fuel-cell-electric vehicles. They are now in the early commercialization phase (505 MW installed as of end-2012), mainly because of the growing popularity of stationary applications. Because the technology in fuel cells and electrolyzers is basically the same, the issues are similar: manufacturing costs and lifetime. Fuel cells are generally slightly less efficient than electrolyzers, but technically more mature.

Combustion turbines can also be used to burn hydrogen – essentially a fuel gas. Pure-hydrogen turbines remain in the early demonstration phase because of limited demand, but would pose only moderate technical issues. However, most turbine manufacturers are focusing their attention on the use of mixture of natural gas and hydrogen in existing power plants. When the ratio of hydrogen exceeds a certain ratio of the mixture, safety, performance and environmental issues are raised.

**The energy efficiency impediment** - The process of converting hydrogen into electricity has a poor level of energy efficiency, ranging from around 30% (for low temperature fuel cells) to 60% (for best-in-class high-temperature fuel cells and combined-cycle gas turbines). Combined with the energy penalty from using electrolyzers and storing hydrogen, these re-electrification losses result in a round-trip efficiency ranging from 20% to, at best, 48%, if technology develops as expected. This means that, from an efficiency perspective, hydrogen will not be competitive with alternative bulk-storage technologies.

Recovering heat losses from re-electrification is essential in improving the energy efficiency of the system. Heat losses can be recycled in two ways: for heating purposes, within combined heat and power [CHP] applications; or converted into electricity in combined-cycle power plants. Depending on the technology, recycling heat can increase the efficiency of hydrogen-to-electricity conversion to up to 60% in the case of combined-cycle power plants, and to up to 80% in the case of high-temperature CHP fuel cells, including heat produced. However, the benefits of CHP are, in practice, highly dependent on the correlation of the heat and power demand curves, and by the presence of a district-heating network or of local demand for process heat.

**Fuel cell: reliability over efficiency** - Fuel-cell technologies are extremely reliable because they lack moving parts. Fuel cells could be particularly successful in applications where reliability and a low maintenance requirement are highly valued, such as back-up and auxiliary power, and uninterruptible power supply. One of the most promising markets is expected to be off-grid telecom towers in developing countries. In cases such as these, the main competitor to H<sub>2</sub> solutions would be diesel generators. Solar PV or wind turbine energy systems that incorporate batteries for diurnal storage and hydrogen storage solutions for smoothing seasonal variations are close to competitiveness in some countries. This illustrates the role that emerging countries may play in the development of off-grid energy storage because of the lack of legacy networks.

**Turbine: power-to-gas applications** - The use of electrolytic hydrogen in combustion turbines should be considered within the broader concept of power-to-gas and as one of the end-use of gas. Indeed, pure hydrogen turbines are unlikely to be needed in the mid-term. As a consequence, the use of hydrogen in combustion turbine will be subject to the common issues faced in the use of hydrogen-enriched natural gas. Blending 1-5% by volume would not require any changes, but higher ratios would require further R&D to mitigate potential hazards (e.g. flame flashback and overheating, embrittlement that could damage turbine) and to limit impacts on local air pollution and performance losses.

# Power-to-gas is an elegant solution at the crossroads of networks and energy sources, but its economics remain highly uncertain

**Power-to-gas [P2G]** - P2G was conceived as a way of using the gas grid to store renewable electricity. But, in practice, P2G does more than this. Its benefits include the “greening” of end uses of natural gas, such as heat generation; it also improves the flexibility of the energy system by pooling gas and power infrastructure. Power and gas grids can be linked in two ways: blending, which involves injecting hydrogen into the gas grid; and methanation – the conversion of hydrogen and CO<sub>2</sub> into methane, also known as synthetic natural gas [SNG].

**Blending** - Gas-distribution networks built to carry town gas, a mixture of hydrogen, carbon monoxide and methane, are familiar with transporting mixtures of methane and hydrogen. However, gas infrastructure and end-appliances have, since the creation of such grids, been designed to operate on pure methane, making the injection of H<sub>2</sub> problematic.

Three main constraints must be addressed: the integrity and safe use of pipeline and grid appliances; the energy capacity of the grid; and the sensitivity of end-use appliances to hydrogen/methane blends. The latter is likely to impose the greatest limitation. In general, the gas grid should tolerate 1-5% volume blending at any point of the network, and up to 20% in distribution pipelines with no critical downstream appliances (and not made of exotic materials).

Even with such conservative assumptions, blending into the gas grid provides large short-term market for electrolytic hydrogen. This is due to the scale of the gas grid, which provides the energy equivalent of around 1,000 TWh both in the UK and in Germany. Hydrogen blending is a low-cost, early-stage solution for monetizing electricity surpluses in countries with a highly developed natural-gas infrastructure. In that situation, business models will depend to a large extent on the cost of hydrogen production by water electrolysis and on the existence of feed-in-tariffs for “green gas”.

**Methanation** - Despite incurring additional capital costs and energy losses – of 40% when heat is not recovered – methanation is considered a promising way of getting round blending-ratio limitations. However, due to the process’s huge CO<sub>2</sub> requirements, it is constrained by the availability of affordable CO<sub>2</sub> sources. CO<sub>2</sub> capture from air is extremely energy intensive, resulting in an efficiency drop from 60% to 39%. As a consequence, methanation is mainly done by recycling large quantities of fatal CO<sub>2</sub>.

For now, the best CO<sub>2</sub> sources are biomethane plants. This is partly because biomethane reactors produce raw biogas, which can be upgraded with electrolytic hydrogen instead of being purified, reducing energy losses by around 10%. In addition, the heat from methanation can be recycled to power the biogas unit, boosting the efficiency of biomethane production from 68.7% to 85.3%. This increases the ratio of methane output to biomass input by a factor of up to 2.5 and optimizes land use, which has societal benefits. In the longer term, large P2G projects could source CO<sub>2</sub> from carbon-capture plants, and would work especially well with oxy-combustion capture technology because electrolysis also produces oxygen, which could be used in the oxy-combustion process.

There are two competing methanation processes: thermochemical catalysis and biological methanation. The former is likely to remain the preferred option in the short to mid-term; Etogas commissioned a 6 MW plant for Audi, in 2013, in Werlte, Germany. The latter, derived from anaerobic digestion processes of producing biogas, may become a viable alternative for distributed small-scale plants. Unlike thermochemical catalysis, biological methanation operates at low pressure. It is also more flexible (it has a quick start-up time) and more tolerant of raw gas impurities. Danish start-up Electrochaea completed a 250 kW demonstration plant in 2013 and has announced a 2.1 MW project to demonstrate upscaling, which is, as with any biological reaction, difficult to achieve.

**Competition with natural gas** - Power-to-gas, whether it involves hydrogen blending or the manufacture of SNG, will struggle to compete with natural gas on a calorific value basis. Hydrogen produced from electrolysis is currently too expensive. The levelized production costs of SNG are still uncertain because of a shortage of reliable data. According to economic models produced by the proponents of methanation, even if there were a significant decline in investment costs, it would not be competitive with natural gas for utilization rates below 50% and for average electricity prices above \$40/MWh. Unless customers are willing to pay a green premium and without a mechanism for integrating lower external costs, P2G is unlikely to become competitive in the short term. However, methanation should be investigated as a solution for decarbonizing heating and mobility, and several countries are considering this option.

# Mobility will probably be the main driver of hydrogen use in the medium-to-long term, but not necessarily for fuel cell electric vehicles

**A vital molecule for mobility** - Contrary to the common perception, the role of hydrogen in mobility is not limited to fuel cell electric vehicles [FCEV]. This is because its chemical energy content is contained in most of the fuels that powers our vehicles: fossil fuels, where it is used to upgrade crude oil or natural gas; synthetic fuels, where it is used as a feedstock or carbon recycler.

**Hydrocarbon upgrader** - Historically, the primary use of hydrogen has been in crude-oil refining processes. In fact, refineries, where hydrogen is a by-product of catalytic reforming, have turned from net H<sub>2</sub> producers to H<sub>2</sub> consumers. This trend is likely to continue. Therefore, using hydrogen in refineries that has been produced from renewable electricity could be, alongside improvements in the efficiency of internal combustion engines [ICE], an elegant way of reducing the carbon intensity of mobility. In a similar vein, hydrogen can be used to upgrade natural gas for natural gas vehicles [NGV]. There are currently more than 15 million NGVs on the road, compared with around 100,000 battery electric vehicles [BEVs]. It is believed that blending hydrogen with methane, and calibrating the engines to run on such a mixture, reduces air pollution and incurs a negligible loss of power performance.

**Feedstock for synthetic fuels** - Methanation, described in the power-to-gas section, is a valuable option for decarbonizing gas-powered transport and is being considered by several European countries, notably Germany and Sweden. Audi has taken the lead with its e-gas project and a 6 MW demonstration plant in Werlte, Germany. Hydrogen could also play a similar producing / upgrading role for liquid biofuels. The easiest solution would be to produce short-chain molecules such as methanol or dimethyl ether [DME], which can be blended with gasoline and diesel, respectively. The 2.8 MW Iceland-based George Olah Renewable plant has been producing methanol from geothermal electricity since 2011. Several other projects are under consideration, including Canadian Blue Fuel Energy. In cases such as these, the integration of high-temperature SOECs capable of co-electrolyzing water and CO<sub>2</sub> could be a game changer. These units could generate – in one step and within a single stack – methane or methanol, which can make use of existing infrastructure. Combining synthetic fuel production with renewable-based hydrogen is not economic at the moment, but is indisputably worth further investigation to quantify the deficiencies and value of H<sub>2</sub> as an upgrading and recycling feedstock.

**Fuel for hydrogen internal combustion engine [H2ICE]** - This type of hydrogen-fuelled vehicle uses a traditional internal combustion engine, modified to burn hydrogen instead of gasoline. Their only advantages over FCEVs are that the engine design is more mature and currently cheaper. Nevertheless, these motors have an efficiency of 24%, which is comparable to diesel engines, but half that of FCEV motors. Therefore, on-board H<sub>2</sub> storage tanks need to be twice as large as those in FCEV vehicles to achieve the same range, and liquefied hydrogen storage is usually required. In addition, the cost of owning this type of vehicle is even more sensitive to hydrogen fuel costs than FCEVs. So is the environmental footprint of H2ICE to the carbon content of hydrogen production. As a result, H2ICEs are no longer considered a viable option.

**Fuel for fuel cell electric vehicles [FCEV]** - Using fuel cells to power electric vehicles [FCEV] has long been considered a promising solution for mobility. FCEVs would benefit from the advantages of electric drivetrains (namely high efficiency and no pollution at the point of use), while not incurring its drawbacks (refueling time, mileage range). However, despite a strong push in the 2000s, FCEVs are still struggling to overcome the deployment “valley of death”. They must resolve three major challenges: onboard hydrogen storage, the durability and high cost of fuel cells, and hydrogen distribution.

However, after years of stasis, FCEVs are back in the spotlight. Automakers have teamed up to renew the push towards hydrogen mobility. In 2013, Toyota and BMW; Daimler, Nissan and Ford; and General Motors and Honda announced partnerships to foster the development of hydrogen mobility. Several public-private mobility programs have also been announced to foster the deployment of hydrogen infrastructure. Recent initiatives include UKH<sub>2</sub>Mobility, H<sub>2</sub>USA and Hydrogen mobility France, following the lead of existing, ambitious programs in South Korea, Japan and Germany.

## Non-energy uses of electrolytic hydrogen could provide market opportunities in remote locations or for customers requiring small quantities of high-purity hydrogen

**Non-energy uses** - Industry is the largest consumer of hydrogen and will remain so in the near- to mid-term. But industry is also one of the main producers of hydrogen, a by-product of several industrial processes. However, despite being distorted by “over-the-fence “ sourcing by refineries, the share of merchant hydrogen has been steadily increasing on a global level – from 6% of consumption in 2003 to 12% in 2011. By 2016, it is expected to reach 16%.

**Refineries** - Refineries produce H<sub>2</sub> as a by-product of catalytic reforming and consume H<sub>2</sub> to reduce the sulfur [SO<sub>x</sub>] content of oil fractions and to upgrade low-quality heavy oil. On a macro level, the H<sub>2</sub> balance of refineries has turned from positive to negative, a trend that is expected to continue because of: more stringent SO<sub>x</sub> regulations; the processing of heavier crudes; and falling demand for heavy end-products and growing demand for light products. Most of this deficit will be supplied by the reforming of natural gas. Electrolytic hydrogen is not yet able to compete with steam methane reforming, but it could provide operational flexibility for refineries that are close to hydrogen equilibrium.

**Ammonia plants** - For the same reason, electrolytic hydrogen will remain marginal as a feedstock for ammonia plants. Ammonia synthesis, which consumes more than half of the hydrogen produced worldwide, is a captive market and usually coupled with steam methane reforming in large integrated plants. However, small-scale ammonia production for fertilizers, coupled with distributed renewable electricity production, could make economic sense in remote locations. In such places, the cost of transporting ammonia might make electrolytic H<sub>2</sub> competitive. Several projects have been considered, but none has yet been completed.

**Small-scale industry uses** - Small-scale industrial applications, such as semi-conductor factories, food factories and hospitals, may be the most attractive industrial markets. Merchant hydrogen distributed in cylindrical pressure tanks is sold for around \$8-15 /kg (\$203-381 /MWh) to large industrials. The price varies according to purity, volume, contract length and the market price of natural gas, and a significant premium is charged for very small quantities. Decentralized H<sub>2</sub> production using electrolysis may therefore be competitive in this type of market and provides an interesting testing ground for electrolytic H<sub>2</sub>.

# The business cases for hydrogen conversion are very complex and rarely viable under current market conditions and existing regulatory frameworks

**Cost reduction & benefit monetization** - - The main challenge for hydrogen conversion is economic rather than technical. Even if the underlying technologies are at different stages of maturity and, in some cases, are yet to demonstrate their feasibility, the technology itself does not appear to be a significant impediment to the development of electrolytic hydrogen. The main uncertainties lie in the scope for cost reductions and monetizing the benefits of hydrogen services.

Cost reduction is a prerequisite for commercialization. Beyond innovations that could disrupt the technology landscape (e.g. new catalysts), the principal areas of focus is engineering and manufacturing to allow for greater scalability and capitalize on accumulated knowledge.

Furthermore, the benefits of electrolytic hydrogen solutions are difficult to assess and monetize. Most putative end-markets are virtually non-existent today and subject to the growing penetration of variable renewables. A few niche applications, such as back-up power in remote locations, could emerge in the short term, but are unlikely to develop into a mass market in which significant cost reductions could be achieved.

**Hydrogen product and conversion services** - The use of electrolytic hydrogen as a product is closer to commerciality, as electrolytic hydrogen fits better in the current market structure and fetches higher end-market prices than when conversion is monetized as a service. However, in current market conditions and with the exception of a few merchant hydrogen applications, support mechanisms for low-carbon solutions will still be needed. For instance, hydrogen blending and methanation cannot compete with natural gas on a calorific value basis in the absence of a premium for being carbon neutral.

Putting conversion services into effect – such as electricity storage for price arbitrage, baseload plant optimization or deferred investment in the power grid – seems difficult in the near term. Providing grid services using electrolyzers for control power is a noteworthy exception.

Remote areas and islands could offer opportunities to trial the monetization of hydrogen services by testing the economics of power mixes with a high contribution from renewable energy, and the ability of such mixes to guarantee energy supplies. Hybrid back-up power solutions with batteries, for example, could be economic for remote telecoms towers powered by solar PV electricity.

**Business model challenges** - Reflecting the complexity of hydrogen's technical value chain, numerous stakeholders interact in hydrogen conversion, storage and end-uses. This complexity may be an impediment to hydrogen conversion, as it could dissuade small players from investing. Simplifying and clarifying processes and regulation is therefore essential for making the conversion business model attractive.

Business models for conversion will require further R&D to develop optimization tools. As underscored in this report, the profitability of hydrogen is likely to depend on the bundling of applications and revenue streams. The numerous inputs and outputs that exist require multi-dimensional optimization tools, which are, at present, lacking in the energy sector. Academic research has made more progress on the technical side than in economics and finance. A significant effort is, therefore, essential in order to develop the modeling dimension.

Finally, the economics of hydrogen-based energy storage solutions are inherently system- and application-specific. Investors, policy-makers and decision-makers, therefore, need to assess how appropriate hydrogen-based solutions are compared with the alternatives, in the context of local, application-specific conditions. Storage modeling must be done at a very high level of detail in the dimensions of time and space to be useful and this remains a real challenge for the industry.

# Hydrogen solutions based on renewables incur few environmental challenges, but safety concerns and social acceptance should not be underestimated

**Environmental impacts** - The conversion of variable renewable electricity to hydrogen incurs few environmental challenges. In general, hydrogen-storage solutions result in lower emissions than other energy-storage technologies, although their full lifecycle pollutants and GHGs emissions depend on the primary energy source and power-production technology.

Land use is also very unlikely to be a constraint on hydrogen-based conversion solutions, although renewable-based systems could face problems because of their land requirements. Electrolyzing modules require a minimum surface area (typically around 75 m<sup>2</sup>/MW of H<sub>2</sub>, as low as 16.7 m<sup>2</sup>/MW for PEM). When hydrogen is used to enrich biofuel production by recycling excess of CO<sub>2</sub>, it is actually maximizing the land use of bioenergy.

Finally, the water requirement of electrolysis – water is used as a feedstock and for cooling – is an important factor to consider in an environmental-impact assessment of H<sub>2</sub> solutions, but is usually lower than for other low-carbon power generation technologies. Typically, around 250-560 liters of water are required per MWh of hydrogen produced. Cooling requirements are much higher, but can be avoided by using evaporation towers and closed-loop circuits.

**Safety challenges** - Hydrogen raises safety challenges due to the combination of its flammable, explosive nature and its molecular composition. The risks are relatively limited in open-air conditions, where hydrogen quickly rises and dilutes into non-flammable concentrations. But, in confined spaces, it may lead to high concentrations at the top of an installation, increasing the risk of explosion and fire.

In fact, hydrogen risks are particularly problematic because hydrogen leaks are difficult to detect. Hydrogen is colorless and odorless, and the addition of an odorant is not possible because of the gas's small molecular size. It is virtually undetectable to humans. Sensors are therefore crucial in preventing incidents. Although they exist and are used in industry, the technologies are very bulky and expensive, and cannot reliably distinguish between hydrogen and methane molecules. A history of false signals makes them impractical for a wide deployment of H<sub>2</sub> solutions. Further R&D is needed into sensors, testing facilities and certification.

**Education and social acceptance** - Finally, international collaboration is essential for the development of harmonized regulation, codes and standards. Hydrogen has a history of safe use in the chemicals and petrochemicals industries, where it is handled in similar ways to other fuels. Small end-users, meanwhile, are subject to very stringent regulatory frameworks that may be over-protective. Passing from limited use by trained workforces to public use will require a delicate balancing of existing regulations.

In addition, the use of hydrogen as an energy carrier is a relatively new concept and may be vulnerable to erroneous public perceptions. To that end, education is essential and must provide information on safety as well as emphasizing the environmental advantages of hydrogen as a fuel.

## Conclusion - the value of hydrogen-based solutions lies more in conversion than in storage but there is still a long way from mass deployment

**Conversion more than storage** - The value of hydrogen-based energy solutions lies predominantly in their ability to convert renewable power into green chemical carriers – hydrogen, methane, methanol and ammonia. In other words, hydrogen's value lies mainly in its versatility. More than just an energy carrier, hydrogen can act as a bridge between different branches of the energy-supply system – optimizing the use of energy generated from renewable power at the energy-system level while also utilizing chemicals infrastructure.

Applications of hydrogen-based conversion solutions are, in essence, system-specific. However, whatever the end-use and the energy system, the development of hydrogen-based solutions is subject to three pre-requisites: a greater penetration of variable renewables in the power mix; the reduction in the cost of electrolysis; and some kind of support from public authorities in the near and medium terms.

**Public and corporate support needs** - Individual hydrogen-based technologies are now sufficiently proved to enable the establishment of large, integrated demonstration projects. These, however, are still largely locked in the investment “valley-of-death” – where technology is both expensive to demonstrate at full scale and its feasibility/profitability remain uncertain, although mid-scale demonstration projects exist in Europe. As a result, public and corporate funding remain essential.

In addition to R,D&D funding, public authorities must harmonize and adapt regulations, codes and standards [RCS] to enable growth in the hydrogen industry. This includes reviewing the conditions under which electrolyzers contribute to ancillary services, introducing RCS governing natural-gas blending, and fostering social acceptance and education by engaging stakeholders and by training future hydrogen professionals.

Finally, public authorities have a wide variety of temporary incentives at their disposal to help transform hydrogen-based solutions into self-sustaining commercial activities. These include feed-in tariffs, grid-fee exemptions, tax exemptions, and quotas. The choice is primarily a political decision and depends on the particular features of each system.

## Section 1 - Making the case for hydrogen conversion



# Summary & Key Findings: Section 1

- 1. Renewable energy sources are at the forefront of the drive to decarbonize the power system, together with electricity savings, carbon capture and storage [CCS] and fuel switching (coal-to-gas, nuclear).** Wind power and solar photovoltaic [PV] energy have been the fastest-growing renewable technologies and are expected to continue expanding rapidly. Unlike electricity production from traditional energy sources, such as hydrocarbons, nuclear and biomass, intermittent renewable energy, like wind and solar PV, is flow energy. Its production is variable, largely uncontrollable and sometimes hard to predict, while the most favorable locations for generating variable renewables are often far from consumption centers.
- 2. Wind and solar PV systems make demand-supply matching more difficult since they increase the need for flexibility within the system, but do not themselves contribute significantly to flexibility.** The increased need for flexibility is reflected in the residual load variations (demand minus intermittent output). The minimal participation in flexibility pool resources is mirrored by the low capacity credit of wind and solar that are granted by system operators to measure the amount of power that they can reliably be expected to produce at peak of demand.
- 3. Flexibility management can be optimized** by perfecting models for forecasting output from wind and solar plants, fine-tuning market regulations and refining the design of power systems. **But additional flexibility will be needed** in the form of demand-side participation, better connections between markets, greater flexibility in base-load power supply or electricity storage.
- 4. Mid- and large-scale electricity storage is not new.** In 2012, an estimated 128 GW of storage capacity was installed around the world. However, 99% of that was pumped hydropower storage, which uses the gravitational potential energy of two vertical reservoirs. All other technologies, including compressed air energy storage, flywheels, batteries and hydrogen-based solutions are at earlier stages of development and still have to demonstrate their commercial potential.

**Electricity storage is a three-step process that consists of withdrawing electricity from the grid in times of surplus, storing it and then re-injecting it at a time of shortage.** There are two main elements to measuring this process: (1) the power capacity of the charging/discharging phases, measured in watts, which defines the ability to withdraw/inject electricity from/to the grid, and (2) the energy capacity of the storing phase, measured in watts hour, that quantifies how much energy could be stored.

**Given this, electricity storage technologies are not necessarily in direct competition with each other, as they may be designed to handle differing storage needs.** Flywheels, supercapacitors and some types of battery will be competing for use in power quality applications that mainly value power capacity (e.g. frequency and voltage control). However pumped hydro storage and compressed air energy storage are best for energy management (e.g. price arbitrage) and load shifting (grid investment deferral) applications that value energy capacity and the discharge time.

**Increasing use of wind and solar PV is bringing the potential and limitations of existing storage applications into sharp focus.** It may also create new frontiers in electricity storage, given the need to meet long-term (seasonal), large-scale (terawatt-hours) needs that chemical-based storage technologies seem best able to satisfy.

## Summary & Key Findings: Section 1 *continued*

5. **Hydrogen-based energy storage solutions are based on the chemical conversion of electricity into a new energy carrier, hydrogen, by means of water electrolysis**, in which electric current splits water [H<sub>2</sub>O] into its constituent elements, (di)-hydrogen [H<sub>2</sub>] and oxygen [O]. Once produced, hydrogen acts essentially like a fuel gas. This is relatively familiar to utilities used to handling gaseous fuels, such as natural gas and town gas, a mix of hydrogen and carbon monoxide that has been in use for decades. To provide electricity back to the grid, hydrogen can be fed into a fuel cell (reverse electrolysis), or fed into combustion engines or gas turbines, similar to those used with hydrocarbon fuels, where the hydrogen gas is burnt.
6. **Chemical storage, exploiting hydrogen's versatility and energy value per mass opens up alternatives to the usual approach to electricity storage, due to its three-dimensional shifting ability:**
  - *Time-shifting*. Even though the volumetric energy density of hydrogen is not as good as hydrocarbons, it still offers unrivalled energy density compared to other bulk storage technologies such as pumped hydro storage. It represents the only technology that would be able to bridge several weeks of windless or cloudy conditions or to provide security of supply on the same level as gas or oil stocks;
  - *Location-shifting*. Hydrogen-based technologies could also reduce infrastructure investments for integrating wind and solar PV generators to the grid. The conversion into hydrogen of temporary excesses of electricity produced from renewables enables existing networks to be leveraged: (i) the power network, by locating storage facilities at congestion nodes to level the load (as with any storage technology); (ii) the gas network, when it already exists as a legacy gas network; (iii) hydrogen road, rail and maritime transport options and, in some regions, hydrogen pipelines; and
  - *End-use-shifting*. The versatility of hydrogen-based storage solutions, compared with other electricity storage technologies, means they are not restricted to producing electricity. Hydrogen can be used in its traditional markets, as an upgrader in refineries for removing sulfur from sour crude and enriching heavy oil fractions into lighter, more valuable products. It can also be used as a commodity in many industrial processes, such as ammonia production and in semiconductors. As a transport fuel, hydrogen can be used not only in fuel cell electric vehicles. It can also be blended with natural gas in gas networks or in gas refueling stations to fuel compressed natural gas vehicles without any change in the process (up to certain limits). Hydrogen is also commonly used to synthesize liquid and gaseous fuels (e.g. methane, methanol, dimethyl ether) that are essentially chains of hydrogen and carbon molecules.
7. **Why hydrogen-based energy storage? And why now? Energy systems must be considered as a whole**, as the IEA advocates in the 2012 edition of its Energy Technology Perspectives: "Efficiently integrating different sectors and technologies is critical, because technologies interact and depend on each other... In this context, systems thinking is essential to explore opportunities to leverage technology deployments within existing and new energy infrastructure." To that end, hydrogen could play a key role as a bridge between intermittent electricity provided by wind and solar energy and the dominant molecular energy system based on hydrocarbons. However, hydrogen technologies have yet to demonstrate their potential and overcome their efficiency, cost and safety challenges.

## 1.1 - The intermittency challenge



# Low carbon technologies are needed to reconcile increasing energy demand with the decarbonization challenge

Global energy demand has increased by more than 67% from 1980 to 2009, increasing CO<sub>2</sub>-related emissions from 18 Gt to 31 Gt per year in 2009 (figure 1). The energy system accounts for 67.4% of global greenhouse gas emissions [GHG], with CO<sub>2</sub> alone representing 61% of the total. The Intergovernmental Panel on Climate Change [IPCC], to which thousands of scientists contribute, reached a consensus that these manmade GHGs are largely responsible for the global warming that has occurred concurrently, as their concentration in the atmosphere has increased. The IPCC has warned that accelerating global warming would have catastrophic effects.

According to the IEA, if the current demand trajectory and average carbon intensity remain unchanged, average annual global CO<sub>2</sub> emissions of 58 Gt would result by 2050, probably inducing an increase in global temperatures of at least 6°C in the long term (6DS scenario). If all decarbonization and energy efficiency measures announced so far were applied, carbon emissions would still increase to 40 Gt per year, slowing global warming to 4°C (4DS scenario). So the IEA is calling for urgent action to reduce emissions to 16 Gt per year in order to limit global warming to 2°C by 2050 (2DS scenario).

To that end, all decarbonization levers must be used: limiting losses during processing and distribution (e.g. heat & power cogeneration), decarbonizing fossil fuels (e.g. carbon capture & storage), promoting more efficient end-appliances (e.g. low energy light bulbs), but also displacing carbonized fossil fuels with renewable primary energy sources, as well as switching from coal to natural gas.

Figure 1: IEA CO<sub>2</sub> emissions and energy supply evolution, plus development pathways

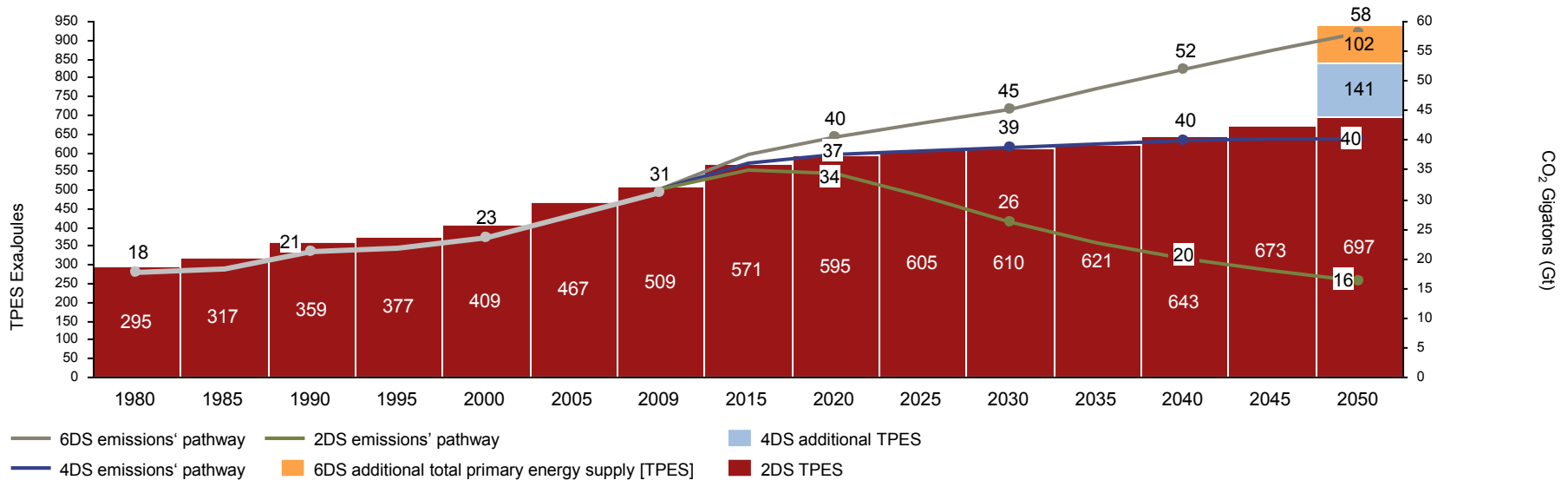

# Box 1: Energy system

An energy system has three main components: (1) primary energy sources, (2) transformation processes and (3) end-energy uses. As illustrated by the figure below depicting the global energy system in 2010:

- Primary energy sources [PES] typically need to be transformed into energy carriers before they can be used by the final consuming sector (91.2% of PES).
- The two main transformation processes are the refining of fossil fuels (51.5% of PES) and the generation of electricity and heat (38% of PES). While energy carriers are easier and cheaper to transport, store or use, they entail large losses: 31.8% of PES are lost in the system through transformation. Electricity generation is the least efficient process, with 62.4% lost during the conversion process and consumed for own use. In some cases, losses can be partly recovered (e.g. cogeneration of electricity and heat, where energy loss through high temperature heat can be recycled to drive steam turbines).
- Each energy carrier requires its own transmission and distribution network (e.g. power grid, gas network, district heating network) inhibiting fuel switching and therefore limiting the flexibility of the system.
- Several energy carriers are competing for the same end-energy uses (e.g. electricity and natural gas for heating buildings), but transport continues to rely almost exclusively on refined products (96.5%).

The decarbonization challenge will put levers in gear throughout the energy system by, for example, reducing end uses of energy, or encouraging consumers to switch to energy carriers that make use of renewables, switching PES from fossil fuels to renewables, limiting energy losses, capturing carbon emissions of fossil-fuel PES. This effort will also face the legacy of existing infrastructure. The midstream segment may provide additional flexibility and is considered essential in the energy transition.

**Figure 2: The global energy system 2010 (ExaJoules [EJ])**

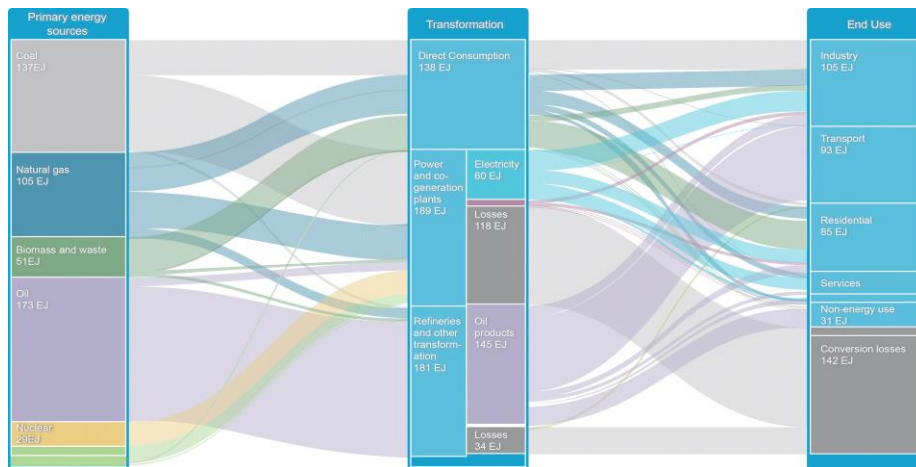

# Wind and solar PV are at the forefront of power-sector decarbonization and set to expand rapidly

**Cutting power-sector emissions is a fundamental step on the path to decarbonization.** Power generation is the largest energy consuming sector (189 EJ, compared with 181 EJ for refining) and the largest generator of energy loss (71%) in the entire energy system (see Box 1). In its 2DS scenario, the IEA estimates that the power sector alone should reduce CO<sub>2</sub> emissions by 42% relative to the 4DS by 2050, a much larger cut than transport (21%). For this purpose, electricity savings and CCS are crucial (28% and 18% of CO<sub>2</sub> reductions in the 2DS relative to the 4DS), but renewables account for the lion's share, with an expected 35% reduction in CO<sub>2</sub> emissions (figure 4).

**Hydropower is still, by far, the dominant renewable power generation technology,** providing about 82% of all renewable electricity in 2010 (16.2% of global electricity generation). But the fastest-growing renewable technologies have been wind power, with 24% average annual growth, from 31 GW in 2002 to 282 GW in 2012, and solar PV, with 51% average annual growth, from 5 GW in 2005 to 96.5 GW in 2012 (figure 3).

**Wind and solar PV are expected to continue growing rapidly,** with wind capacity reaching 490 GW and solar PV capacity 230 GW by 2017, generating 1,065 TWh and 279 TWh respectively. In its most ambitious climate-change mitigation scenario, the IEA estimates that wind and solar PV capacities would need to reach 2,350 GW and 2,000 GW to account, respectively, for 15-18% and 6-12% of global electricity generation by 2050. They are thus expected to be the largest contributors to CO<sub>2</sub> reduction, with wind accounting for 14% and solar PV for 7%.

**Figure 3: Wind & solar PV technologies lifting off (estimates for 2013-2017)** Capacities in GW (left axis) and generation in TWh (right axis)

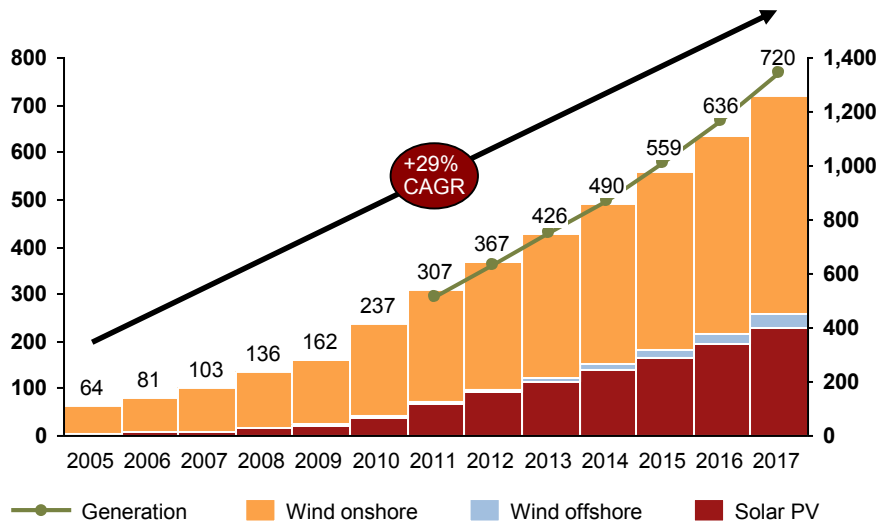

**Figure 4: Key technologies to reduce CO<sub>2</sub> emissions in the power sector in the 2DS, relative to the 4DS GtCO<sub>2</sub>**

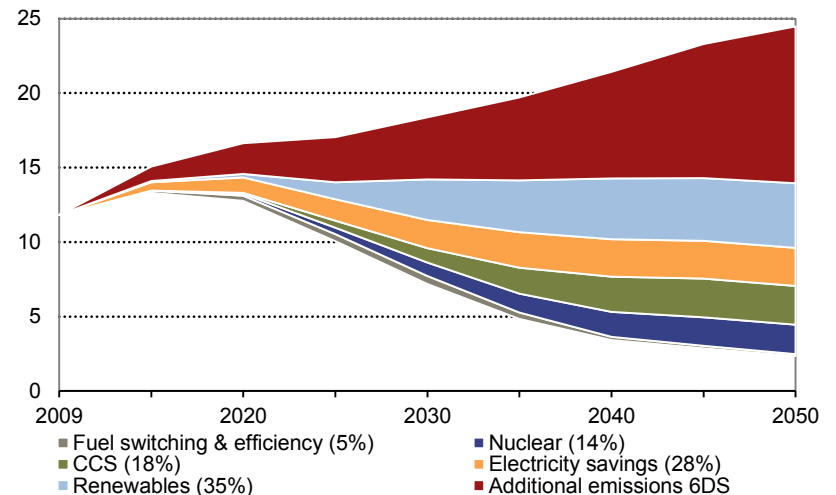

1. Note: CAGR: compound annual growth rate.  
Source: IEA (2012a); IEA (2012b).

## Wind and solar PV generation's dependency on variable primary energy sources, often located far from consumption centers, impedes its integration into the existing power system

**Wind and solar PV technologies are characterized by their intermittency** (figure 5). (1) Output is variable on multiple timescales, depending on daily or seasonal patterns (e.g. day & night for solar power generation) and on weather conditions. (2) This variability makes long-term forecasting difficult and certainly less predictable than output from fossil-fuel technologies. (3) Wind and solar output are subject to ramp events, *i.e.* those that vary upwards and downwards very rapidly (e.g. the shutting-off of wind turbines when wind speeds are excessive or clouds passing over a PV farm).

**Their load factor and thus their competitiveness depend on the quality of natural resources, *i.e.* wind speed and solar radiation. Unfortunately, the best wind and solar resources tend to be far from major consumption centers.** In China, for instance, the fastest wind speed and highest solar radiation are found in the south-west region, while the population and industry are largely concentrated on the east coast. In the US, the best onshore wind sources are mostly in the plains states, far from the most densely populated hubs (figure 6).

**These characteristics do not fit well with the existing infrastructure of the power system.** Electricity is difficult and expensive to transport and store. Prioritizing the provision of reliable and competitive supply, power systems have historically been built to adjust the output of centralized dispatchable generators according to end-user demand variations. They were not designed for variable renewable loading. With an increasing penetration of wind and solar PV, power system management will have to evolve to develop additional flexibility.

**Figure 5: Wind & PV intermittency: 1st-7th of January 2011, northern Germany MW**

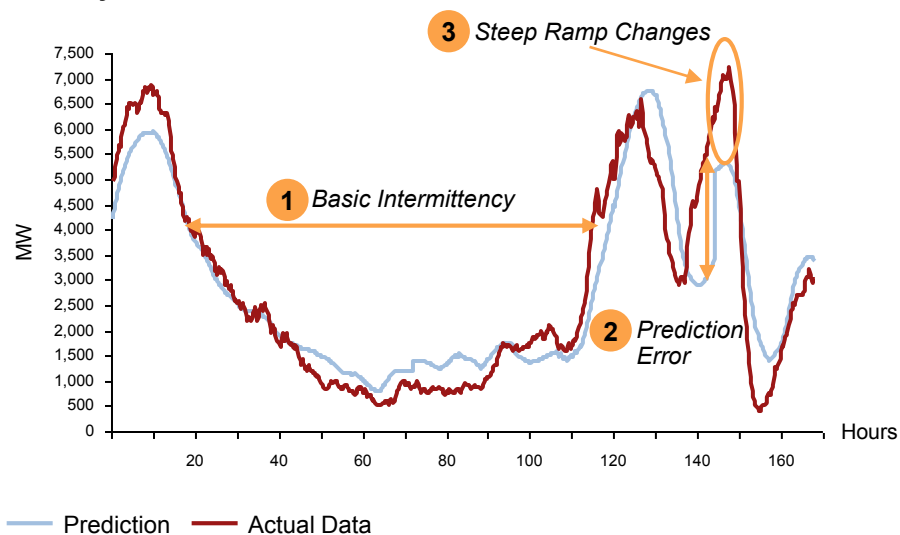

**Figure 6: Wind resources and densely populated hubs in the US**

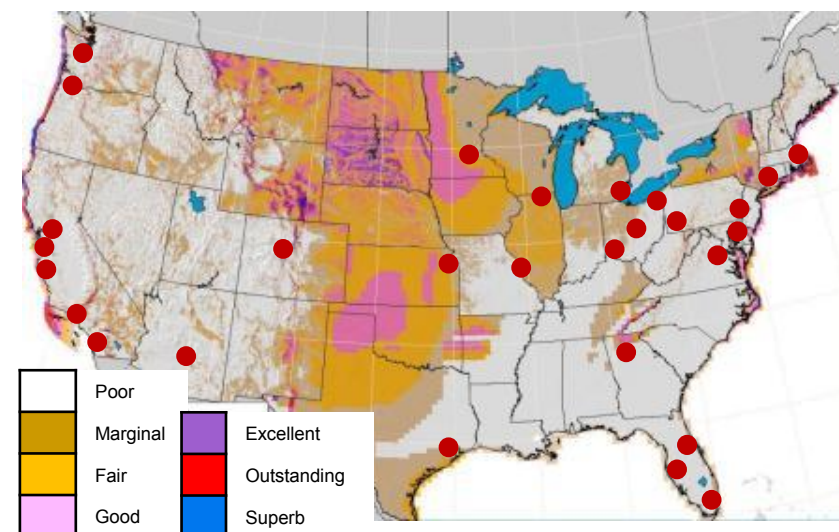

## 1.2 - The need for flexibility



# Flexibility has always been needed in the power system to cater seamlessly to variable demand and mitigate grid and generator contingencies

**Power-system operation is challenging as it relies on the precise balancing of supply and demand at all times.** This constant matching is needed not only to ensure that supply meets end-use requirements, but also to prevent equipment damage, human injury and the negative impact on investment caused by blackouts. The largest blackout in North American history occurred on August 14<sup>th</sup> 2003, and is believed to have contributed to at least 11 deaths and cost an estimated \$6 billion.

**Power consumption changes perpetually.** Its profile follows quite predictable daily (figure 7), weekly (figure 8) and annual patterns (e.g. the load is lower at weekends, due to reduced business and industrial activities, or between midnight and 6:00 am), but it is still impossible to forecast consumption variations perfectly at all times, especially considering generator and transmission line contingencies. This means variability and uncertainty are common to all power systems, which have had to incorporate flexible resources to accommodate load fluctuations.

**Flexibility needs are often divided into three groups, depending on the timescale:**

- **Stability** refers mainly to frequency and voltage control to comply with the grid's technical limits over a period of seconds;
- **Balancing** refers to load changes over minutes or days that must be balanced;
- **Adequacy** refers to capacity needed to meet peak demand even under the most extreme conditions in the long term (months to years).

**Figure 7: Daily load curve on 5th January 2013 in France<sup>1</sup>**

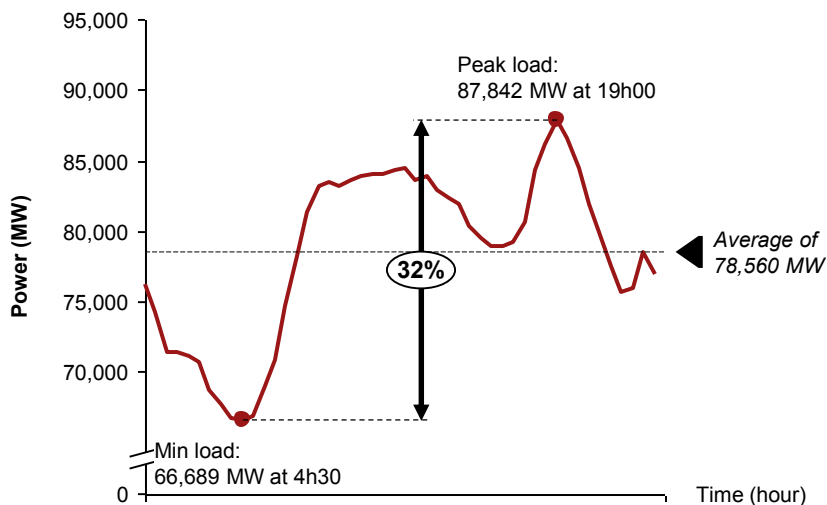

**Figure 8: Weekly load curve in winter vs. summer in northern Germany<sup>2</sup>**

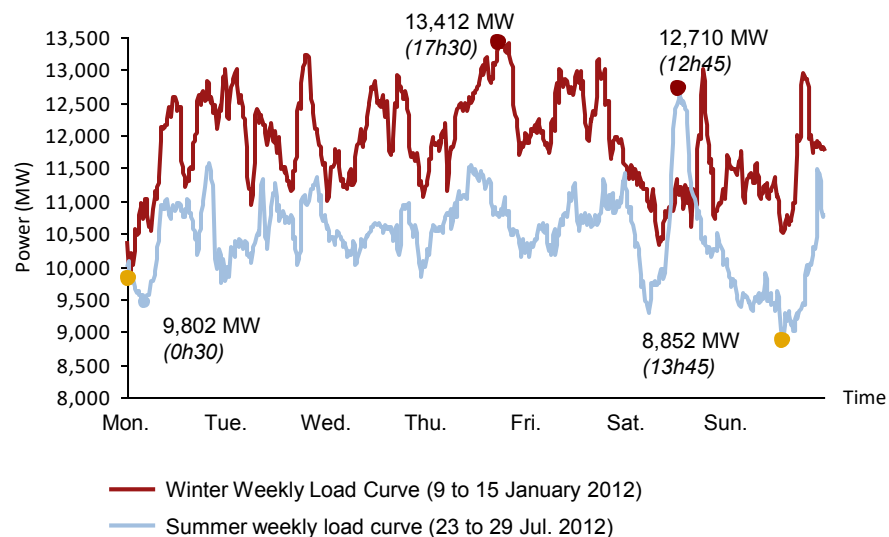

# Current systems are built for flexible generation, able to adjust output according to a defined ramping rate for a specified amount of time

**In the current operating paradigm, generation must follow the load.** The balance between supply and demand is maintained using a hierarchical control scheme, with crude matching at the longer timescale and finer matching at the shorter timescale<sup>1</sup>. Flexibility is, for the most part, ensured by dispatchable generators able to adjust their output upwards and downwards.

**System operators activate dispatchable generators, depending on their flexibility and their marginal cost of production.**

- Minor changes in voltage or frequency can notably provide stability to the grid. To that end, system operators can rely on certain generators that have commitments – to a capacity market or through bilateral agreements with the system operator – to adjust their output up or down, on request, in given time frame and according to a defined ramping rate (figure 9). Known as ancillary services, these capacity reserves are usually at least equal to the power rating of the largest power plant of a power system.
- To meet **balancing** needs and address more predictable changes in demand, such as a morning increase, system operators call upon plants, depending on their marginal operation costs (figure 10). Baseload power plants are designed to operate at full power at all times, though they still have a degree of flexibility (e.g. nuclear, coal), while mid-merit power plants operate discontinuously following their merit order ranking (e.g. combined cycle gas turbines).
- To address **adequacy**, system operators rate power plants according to the amount of power that they can reliably be expected to produce at peak demand times. This capacity is measured by the capacity credit granted to each power plant.

**Figure 9: Categorization of ancillary services used to ensure grid stability**

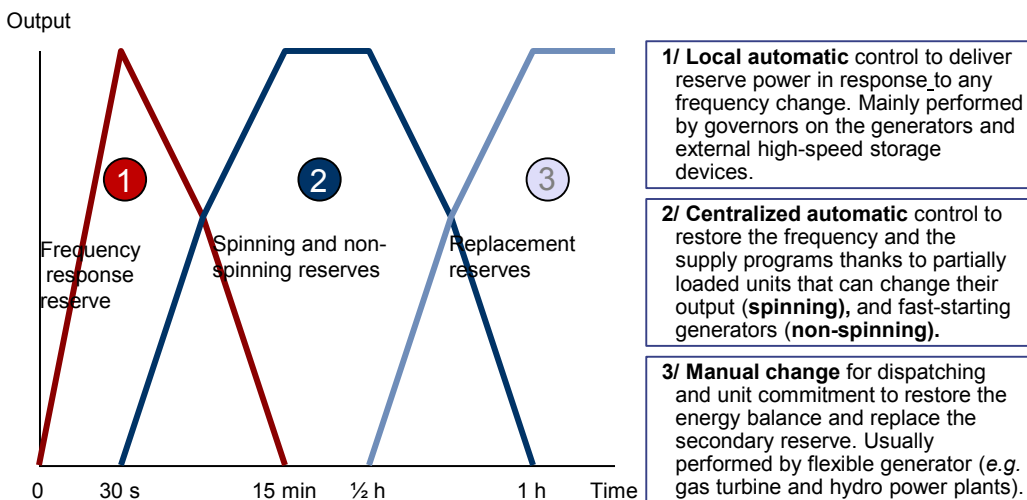

**Figure 10: Price and load duration curves, Sweden, 2011**

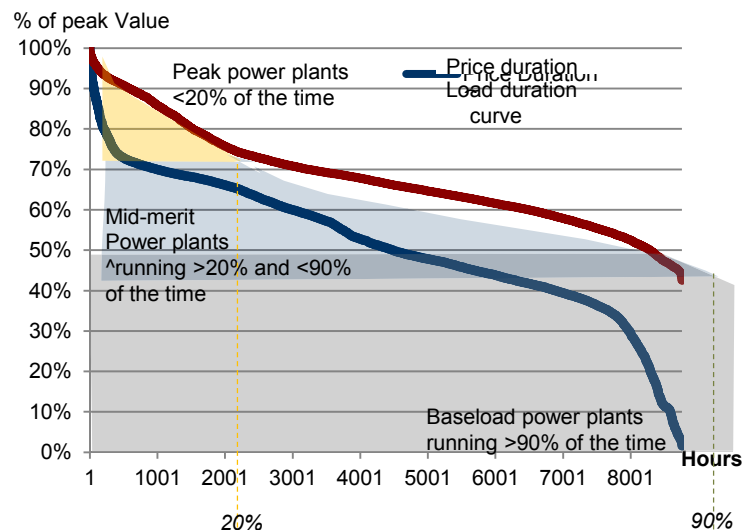

# Wind and solar PV increase flexibility needs without contributing significantly to the pool of resources that can adjust for flexibility, resulting in higher system inefficiency

The intermittency of variable renewables makes it more difficult to balance supply and demand, increasing flexibility needs. Wind and solar output create variability and uncertainty on the supply side, and have the additional problem of being less predictable than demand. Demand follows relatively stable daily, weekly and yearly patterns and is well understood by system operators, reflecting decades of experience and data. The increasing need for flexibility is apparent by observing the residual load (i.e. demand minus wind and solar generation), shown on figure 11.

Variable renewables make virtually no contribution to the flexibility pool of resources, as they cannot be relied upon to produce energy at a given time with any certainty. The IEA estimates in its New Policies scenario that the capacity credit of wind and solar will range between 5% and 20% by 2035 depending on regional variations and technologies. The 5% lower limit for European wind capacity credit means that, out of 450 GW of installed capacity, only 22.5 GW can be relied on to meet peak demand, while average annual output is around 112 GW. From this, it can be estimated that 89.5 GW of additional flexibility capacity (i.e. the difference between average annual output and capacity credit) must be found elsewhere to ensure system adequacy (figure 12).

**Figure 11: Wind & solar photovoltaic generation vs. demand in northern Germany<sup>2</sup> MW, December 2012 on the 50Hertz Operated Gri**

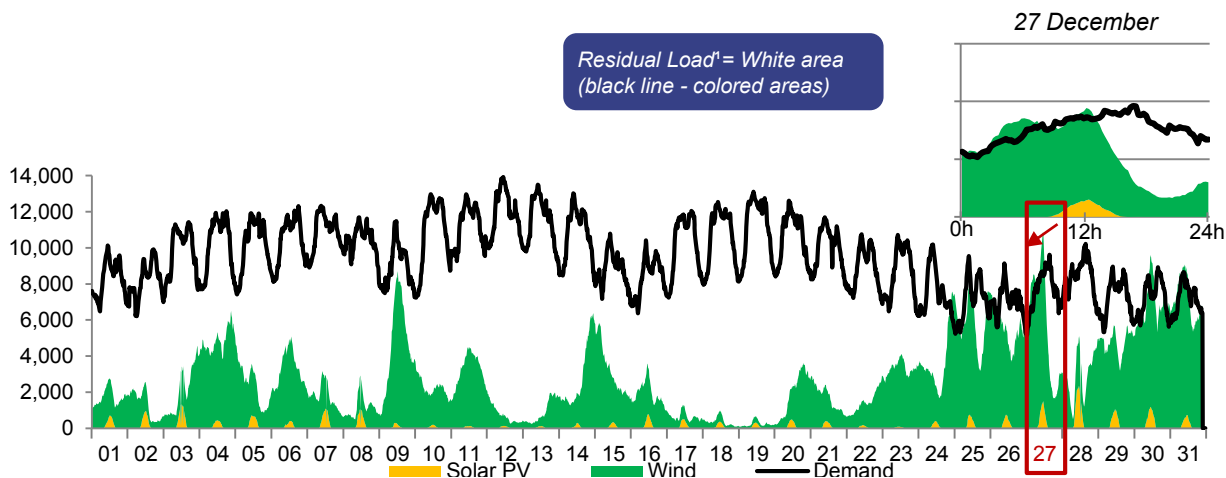

**Figure 12: Capacity credit of wind in 2035<sup>3</sup> GW, project in the IEA New Policies Scenario**

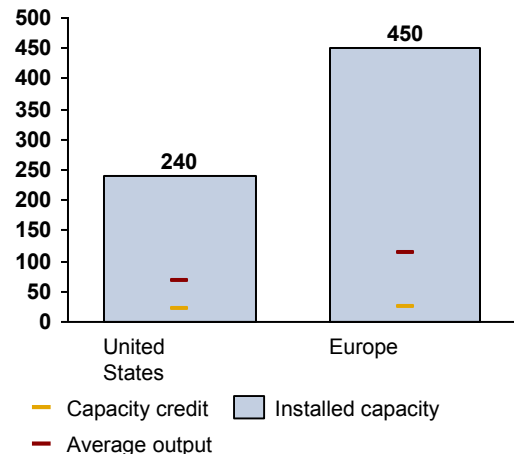

Note: <sup>1</sup>Residual Load varies from -1,985 MW to 13,262 MW compared to 5,164 to 13,927 MW for the load.  
 Source: 2A.T. Kearney Energy Transition Institute analysis, based on 50 Hertz Data (Wind and Solar Actual In Feed 2012, Control Load 2012); 3IEA (2012c).

# Forecast growth in intermittent renewables is expected to add complexity to balancing power supply and demand, increasing need for curtailment and back-up resources

Existing flexible resources may, up to a point, be able to manage the additional load variations that result from the use of wind and solar PV, assuming these energy sources can be used more efficiently. Penetration thresholds are subject to debate and tend to be system specific, but there are upper limits beyond which a radical change in the way power systems operate will be needed.

This is due to three factors. (i) **The ability of variable renewables to meet peak demand declines as deployment increases** – *i.e.* the higher the penetration rate, the lower the capacity credit. (ii) **The average annual power output of variable renewables increases roughly linearly with installed capacity**<sup>1</sup>. As a result, the differential between average annual output and the capacity credit, which measures additional flexibility needs, will increase. (iii) **Variable renewables have the lowest marginal operating costs** because of the absence of fuel costs. They come first in the merit order ranking used by system operators to decide which generator to dispatch.

Consequently renewables will (i) displace baseload plants, increasing their levelized cost of production – very high utilization rates are required to amortize the initial investment in baseload plants (*e.g.* nuclear). They will also (ii) affect the economics of the peak power plants used to back up wind and solar, as back-up plants will be used less often, resulting in price rises to maintain profitability. Finally, (iii) production of electricity from renewables may need to be curtailed, if the system cannot accommodate it (figure 13).

**In the existing power system's operating model, system costs are likely to increase faster than growth in the penetration of variable renewables.**

**Figure 13: Illustrative impact of growing variable renewable penetration on load duration curve & residual load duration curve<sup>2</sup>**

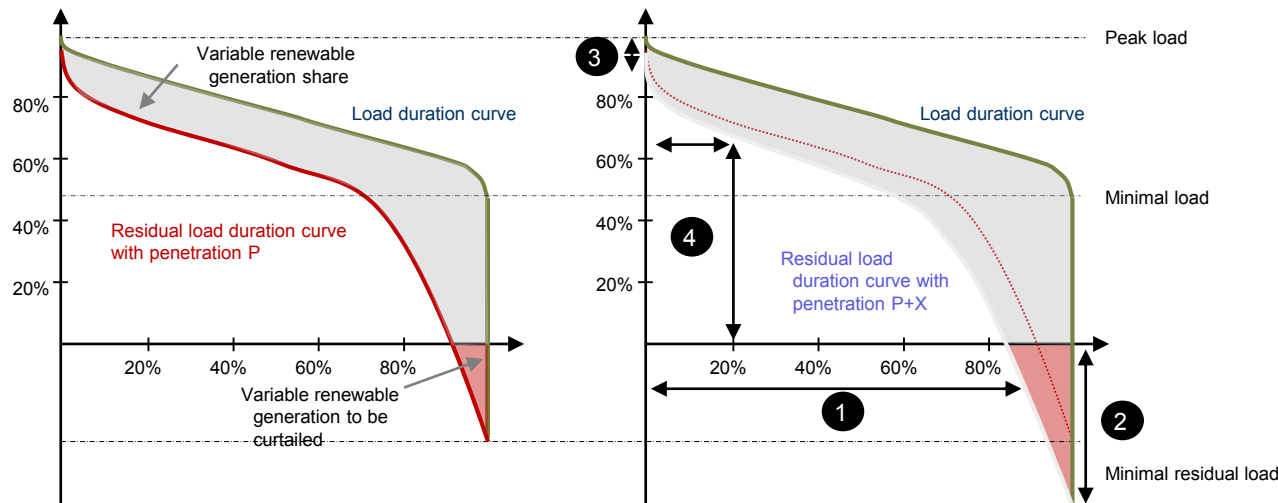

Impact of increased variable renewables in the power mix:

1. Reduce the residual base load *i.e.* full load hours utilization of the power plants
2. Increase the wasted energy *i.e.* time when renewables need to be curtailed due to excessive production.
3. Provide smaller capacity credit *i.e.* participate less in system adequacy.
4. Reduce the utilization of peak power plants running infrequently (<20% of the time).

Note: <sup>1</sup>It could even grow in the coming years as a result of technical innovations that increase the load factor; <sup>2</sup>Assuming no alternative flexibility resources.

Source: A.T. Kearney Energy Transition Institute analysis, based on Ueckerdt et al. (2012).

# New flexibility resources must be developed in addition to dispatchable power plants, including demand-side control, better market inter-connections, more efficient system operation and improvements in energy storage

To mitigate the integration costs of growing variable renewables, system operators will have to draw upon alternative flexibility resources (figure 14). This will be particularly crucial in mitigating the low capacity credit of wind and solar PV and in monetizing temporarily available excess electricity in order to avoid curtailment and waste (e.g. energy storage, and inter-connections covering larger areas to export excess energy and partially smooth the effects of regional weather variations). **Alternative resources are known and are already being used to some extent** (e.g. demand response of industry, export and import, electricity storage), but their role is expected to grow in importance, and their task should be made easier by improved market rules and processes for system management.

**Figure 14: Flexibility resources and flexibility needs in the power system**

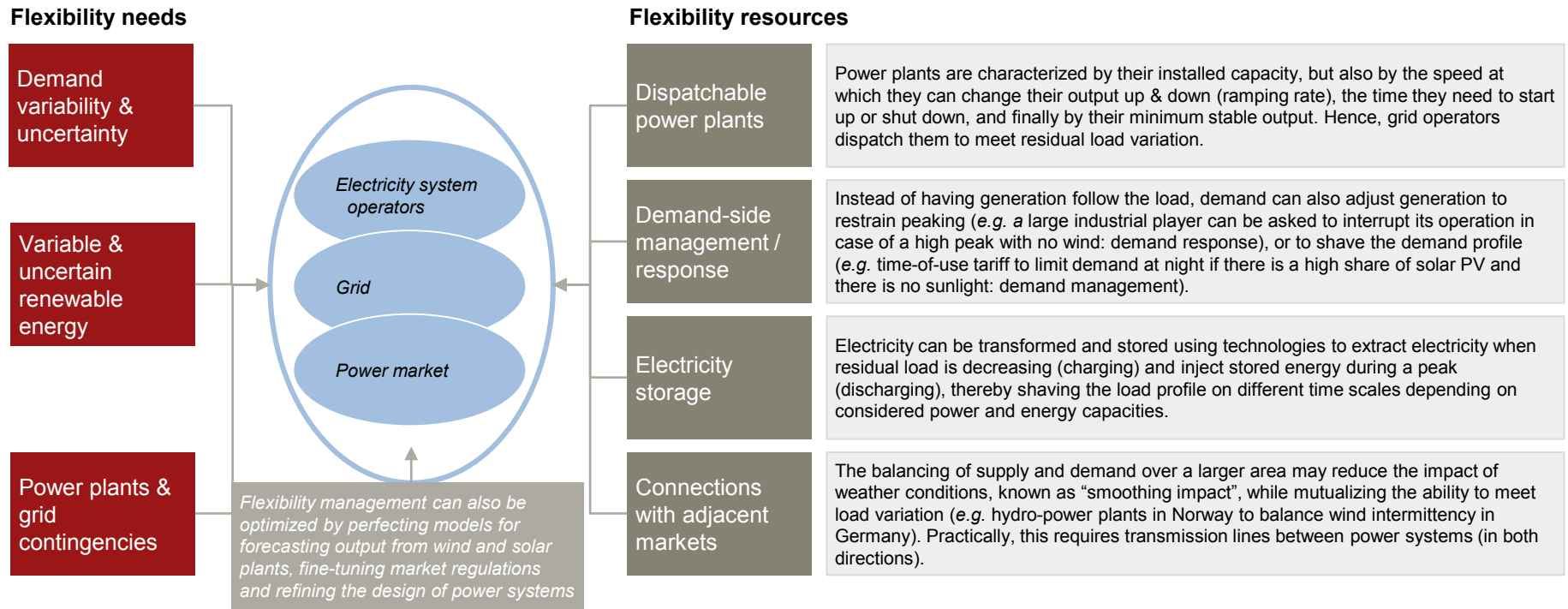

## 1.3 - The new momentum of electricity storage



# Box 2: Energy storage technologies

Electricity can be stored using several physical principles:

- **Electrical energy:** (i) Superconducting magnetic energy storage [SMES] stores electricity in a magnetic field by passing a direct current through a coil of cryogenically cooled, superconducting material, (ii) ultra-capacitor polarizes an electrolytic solution to store energy electrostatically.
- **Mechanical energy:** (i) Pumped hydro storage [PHS] makes use of two, vertically separated reservoirs, pumping water from the low one to the high one during charging and releasing it through a turbine back to the low reservoir during discharge; (ii) Compressed air energy storage [CAES] uses electricity to compress air into a confined space and releases the pressurized air to drive the compressor of a gas turbine, (iii) flywheels use the inertia of a rotating mass within a frictionless container, increasing its velocity under charging and vice versa.
- **Electro-chemical energy:** (i) batteries consist in electrochemical reactions. Upon charging, ions move from the positive to the negative electrodes through an electrolyte (e.g. a molten sulfur positive electrode to a molten sodium negative electrode in NaS batteries); (ii) flow batteries use the same reaction but with two externally stored electrolytes pumped through a single fuel cell upon discharge. It allows the decoupling of power (fuel cell rating) and energy (electrolyte rating).

Thermal and chemical-based solutions are also playing a major role in the electricity storage landscape, but differs from “conventional” electrical energy storage as it uses an alternative energy carriers (heat, molecules):

- **Thermal Storage** stores heat produced in the course of the power generation (e.g. heat from the sun in Concentrating Solar Power plants) instead of electricity .
- **Chemical energy** stores electricity by converted it into a new energy carrier that it stores (hydrogen, synthetic fuel). Once stored, it is not necessarily converted back to electricity.

Figure 15: Energy storage technologies categorizations

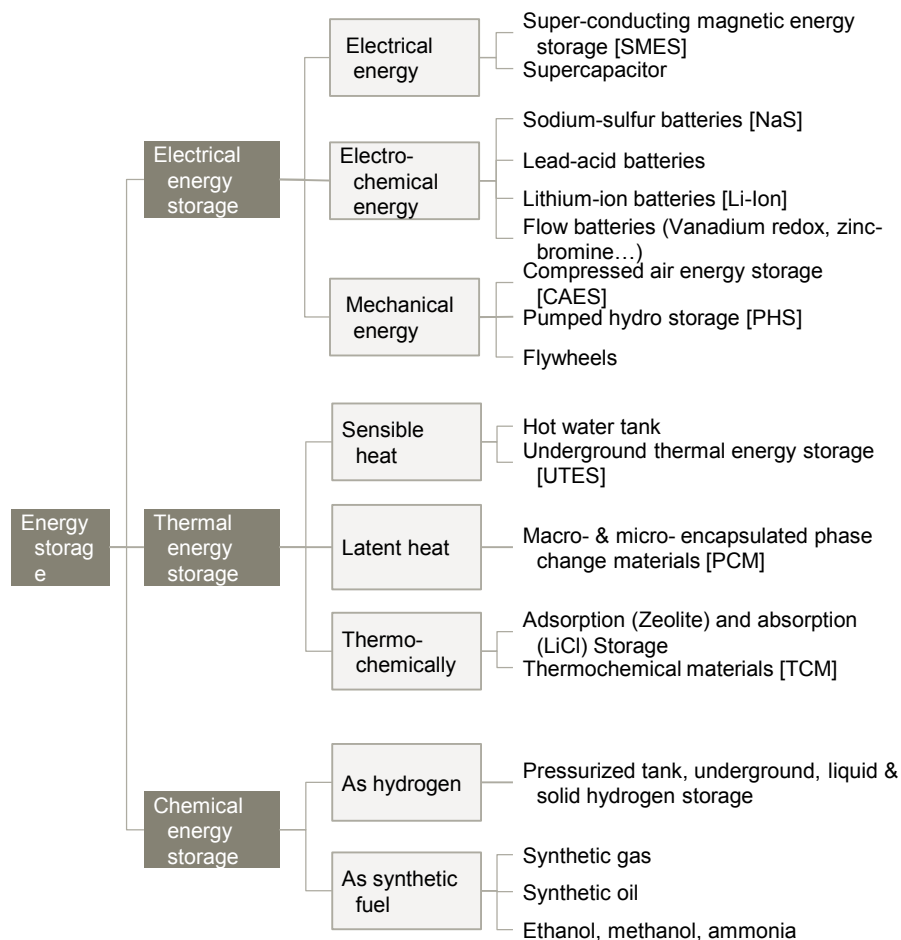

# Large-scale electricity storage, apart from pumped hydro storage, has long been perceived as impractical and has been generally avoided in favor of storing primary energy sources and energy inertia in power generators

Electrical storage is very common in mobile applications involving small storage devices (e.g. mobile phone batteries). However on a larger scale, storage has long been perceived as prohibitively expensive. Power system operators have bypassed the need for electricity storage by instead storing primary energy sources such as coal, gas, oil, biomass (chemical energy) or water in power dams (figure 16) and by using energy stored in the form of inertia in power generators (spinning reserves).

Electricity storage is already a reality, with around 128 GW of capacity installed at the end of 2012. Yet this remains negligible compared with total generation capacity, accounting for no more than 2.6% of the global power fleet.

Pumped hydro storage [PHS] is currently the only widespread large-scale technology. Its development was boosted in the 1980s by price arbitrage opportunities arising from the growing spread between low and peak electricity prices. Attempts to develop compressed air energy storage, batteries or flywheels have, so far, been unsuccessful at a large scale. Their use has been limited to niche applications and a small number of demonstration plants (figure 17). Thermal-based electricity storage is emerging in parallel with the development of concentrating solar power plants. Finally, chemical electricity storage is getting increasing attention, despite still being at an early stage of development, with around 8 MW of demonstration capacity in existence.

**Figure 16: Energy storage dedicated to power producers in the US in 2011<sup>1</sup>**

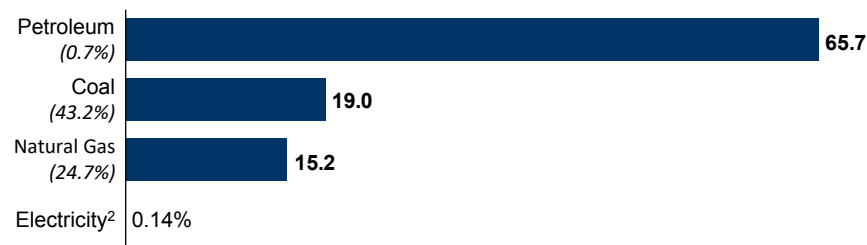

*How to read this graph?*

In this example, coal accounts for 43.2% of total power generated: in 2011, 19% of coal consumed in US power generation was stored and constitutes reserves. Petroleum, coal and natural gas stored for other purposes (e.g. industry) are not included in the graph. They may amount to additional reserves (e.g. total natural gas stored was equivalent to 49% of the gas used to generate power)

**Figure 17: Electricity energy storage installed capacities by technology<sup>2</sup>**

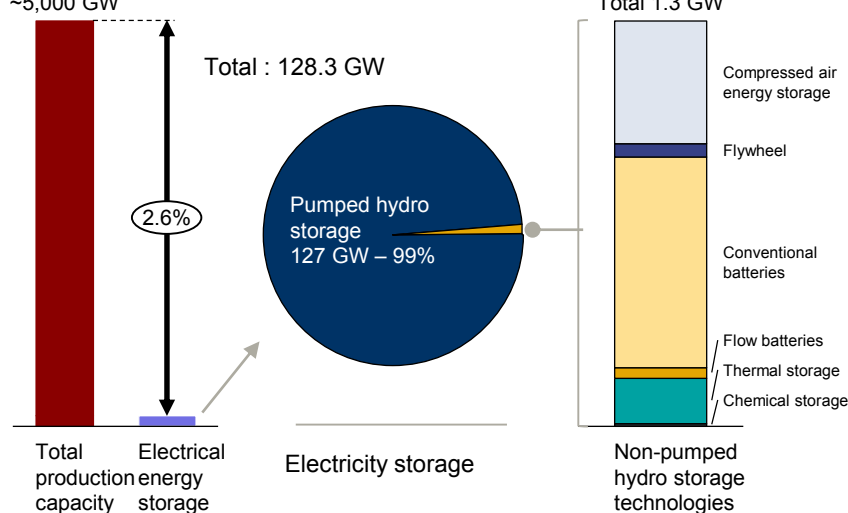

Note: 1The power sector share of the total gas consumption has been applied to the US underground gas stored and does not take into account the pipeline storage capacity. Electricity storage is meant as the electricity used in pumped storage facility. Source: A.T. Kearney Energy Transition Institute analysis, based on 1EIA (2012a); 2EPRI (2010).

# Electricity storage is a three-step process – charge, store and discharge – for leveling the load

Electricity storage is a three-step process, enabling electricity to be withdrawn from the grid in times of abundant supply and low demand, and stored for re-injection at times of low supply and high demand (figure 18).

- 1. Charging** acts like consumption and is characterized by the rate at which energy can be withdrawn (power) and the time needed to start this process (ramping rate).
- 2. Discharging** acts like generation and is characterized by the rate at which energy can be injected (power) and the time needed to start this process (ramping rate);
- 3. The storing phase** adds a time-shift dimension and is characterized by how much energy can be stored (where energy is equal to power multiplied by time).

The combination of power and energy limits the time-shifting ability of a storage system.

- The **power/energy** ratio determines the typical cycling time of the system and provides an indication of the cycling frequency.
- The **energy losses** along the storage chain, measured by the ratio of energy injected to energy withdrawn, define the efficiency of the system. Time-shifting ability can be limited by storage losses, which define duration boundaries.

While electricity storage consists, in essence, of leveling the load, the storage system's power, energy and efficiency characteristics have a great influence on its operational pertinence and determine where it is applicable. Other key factors are initial investment requirements, operation and maintenance costs and reliability.

**Figure 18: Storage systems schematic representation**

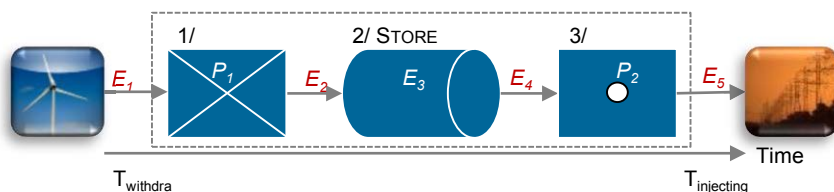

Illustration for a 8 MW charging / discharging storage system

STORAGE RATING (E <sub>3</sub> )	CHARGING TIME
24 MWh	3 hours
4 MWh	30 minutes
192 MWh	1 day

Cycling frequency & efficiency impact, depending on the power/energy ratio

1. Systems with a high power/energy ratio are usually ill-suited for long-term storage and will tend to require high-frequency cycling (a high number of charge and discharge cycles) and vice versa.
2. The importance of efficiency ( $E_5/E_1$ ) increases as the number of charging /discharging cycles rises.

# The application of energy storage entails a wide variety of technical requirements, concerning energy, power, efficiency and location on the grid

Energy storage can be used for a multitude of applications, depending on the system design and its location on the grid. The most important variables are the power requirements and the desired discharge time of the storage unit (figure 19):

- 1.Short-term storage** is usually used as a power management tool to ensure power quality (frequency and voltage control), as well as an uninterrupted power supply (frequency response reserve).
- 2.Medium-term storage** (from an hour to a day) is used to shift the load to shave daily peaks. This may help avoid grid congestion, and can also take advantage of price differentials between low- and high-demand periods (price arbitrage).
- 3.Long-term storage** is used to level the annual load (e.g. winter and summer patterns), minimizing the need for capacity reserves, as well as ensuring security of supply.

The strategic location of stores on the grid plays an important role in avoiding or deferring investment in transmission and distribution [T&D] lines and integrating distributed renewables. Most applications are considered to be on the generator side, but T&D operators and end-users are also important storage stakeholders (figure 20).

Figure 19: Applications depending on discharge time and capacity<sup>1</sup>

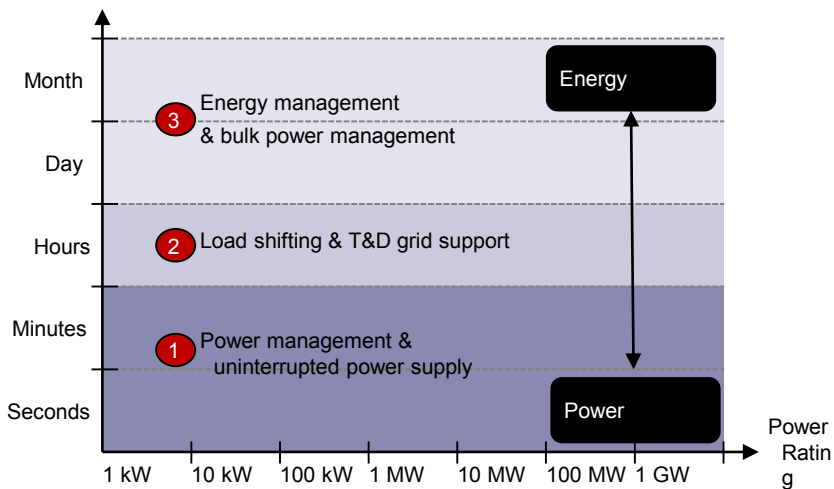
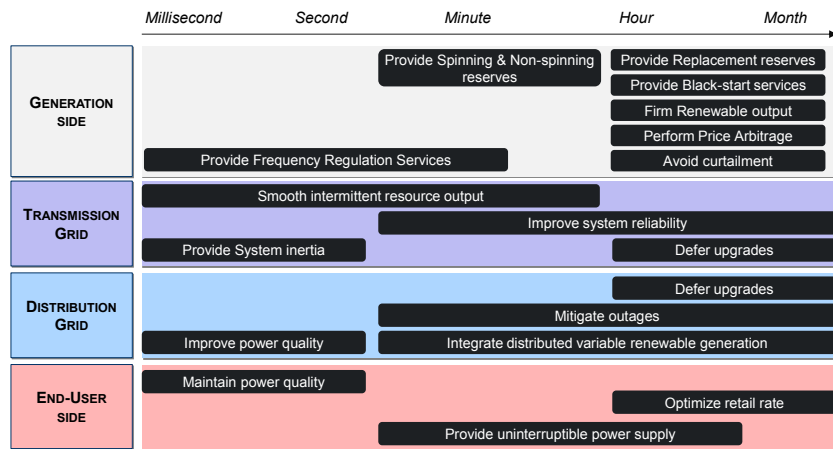

Figure 20: Applications depending on grid location<sup>2</sup>



Note: Spinning reserve is generation capacity that is already operating and synchronized to the system that can increase or decrease generation within a limited timeframe (10 minutes in the U.S.); Non-spinning reserve is capacity that is not operating, but can be up and running within a limited timeframe (30 minutes in the U.S.) to provide generation if needed.  
 Source: A.T. Kearney Energy Transition Institute analysis, based on IEA ECES (2012); EPRI (2010).

# Storage applications are critical to ensuring variable renewables can be integrated into the grid

## Greater use of variable renewables increases the importance of storage applications:

- 1. Power quality** may diminish due to sudden variations in wind and solar output (e.g. higher wind speed than a turbine's capacity).
- 2. Daily load** is more variable and uncertain, resulting in higher peaks to be shaved off in order to limit reserve requirements or to take advantage of price differentials.
- 3. Energy management** becomes critical to avoid expensive capacity-reserve needs.

Integrating variable renewables is often considered a specific storage application, even if it tends to be a combination of current applications. The link between the market price of electricity and generation variability is illustrated in the graphs below using market projections for the Irish market in 2030 (figure 21).

**Figure 21: Irish market projections for 2030 based on weather patterns from January 2000 adapted from Pöyry<sup>1</sup>**

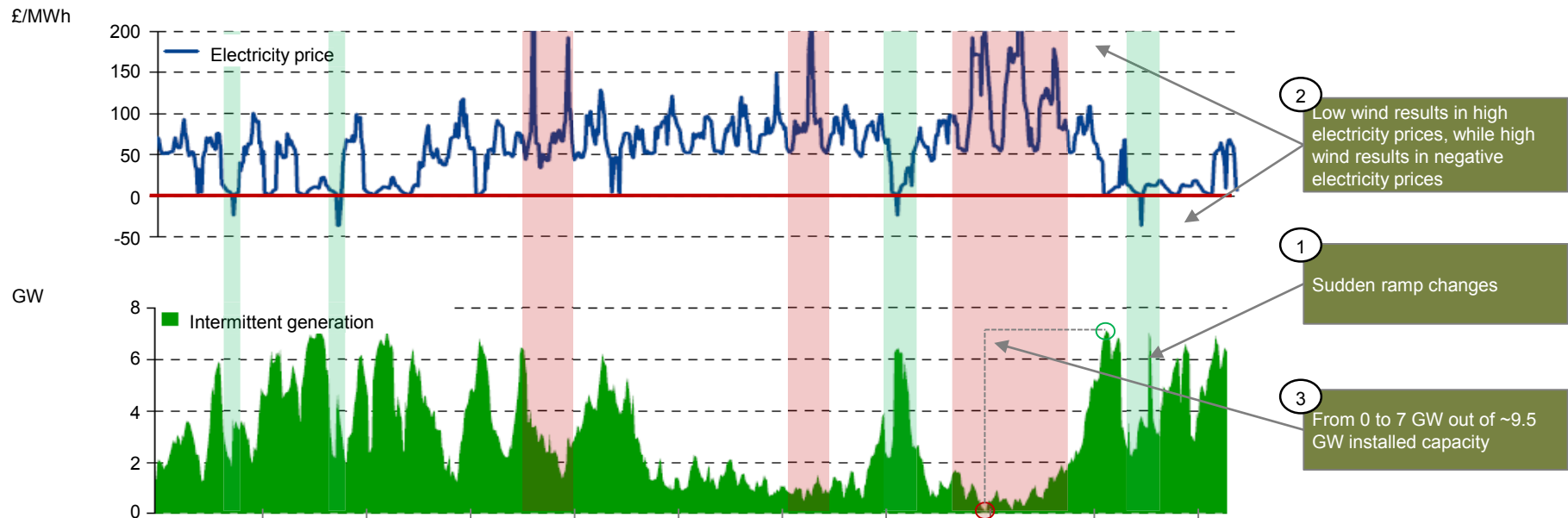

# Several storage technologies are under development but their features must match application requirements

In order to cope with the growing need for energy storage, several electrical and chemical energy-storage technologies are being developed (figure 22). Technologies are still constrained by their design limitations and can therefore only compete for applications suited to their technical features. For instance, pumped hydro storage is not competing for the frequency-response market, as it has a high power and energy rating (figure 23).

- Flywheels, supercapacitors and superconducting magnetic energy storage [SMES], as well as some chemical batteries, such as nickel metal hydrides [NiMH] and lead-acid, are competing to provide power quality and reliability.
- Batteries with a multitude of chemical compositions – such as sodium sulfur [NaS], lithium ion [Li-ion] and lead acid – are competing with flow batteries – such as vanadium redox [VRB] and zinc bromine [Zn Br]; two externally stored electrolytes enable flow batteries to decouple energy and power, for hour-to-day load shifting. Flow batteries are scalable and could compete for applications with wider power and energy ranges.
- Pumped hydro storage [PHS] and compressed air energy storage [CAES] are the main technologies for power-fleet optimization and large-scale intermittent balancing.

Hydrogen-based storage solutions (using fuel cells for small power requirements and combustion turbines for large power needs) are the only technologies that can meet intermittent balancing requirements at very high penetration levels.

Figure 22: Electricity storage application requirements

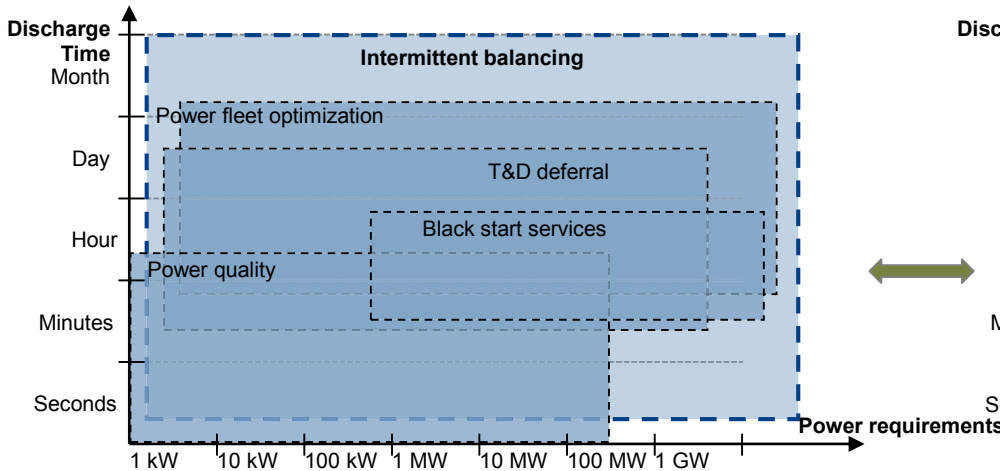
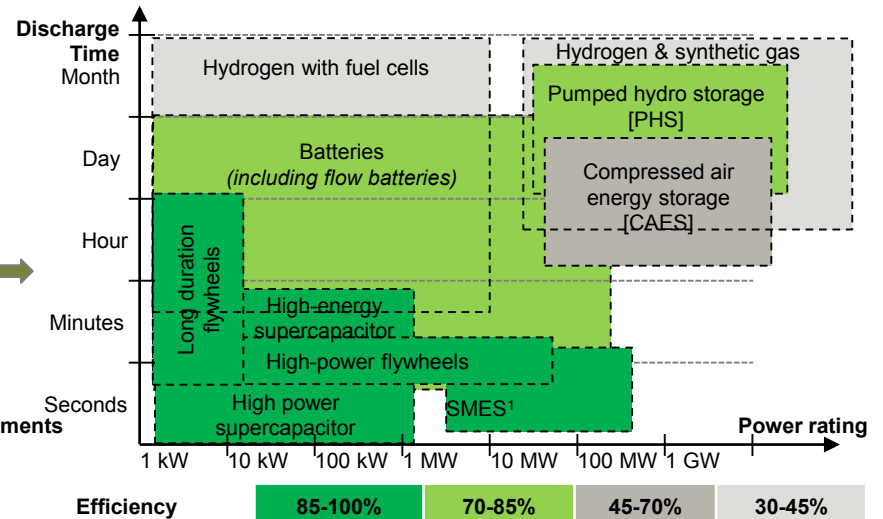

Figure 23: Electricity storage technologies' features



Note: SMES: superconducting magnetic energy storage.  
Source: A.T. Kearney Energy Transition Institute analysis, based on US DoE (2011) and Hydrogenics (2012).

# A very high penetration rate for variable renewables will make large-scale, long-term energy storage indispensable

**The increased penetration of variable renewables in the electricity mix is expected to create new long-term (seasonal) and large-scale (TWh) electricity storage requirements.** It is likely to reduce the correlation of supply and demand, generating very large deficits of supply at times of high demand, if the weather is unfavorable, and significant surpluses when demand is low but the wind is blowing or the sun is shining.

The Fraunhofer Institute simulated a 100% renewables-based electricity system for 2050 on behalf of the German Ministry of Environment. With load management (e.g. scheduling charging times for electric vehicles or air-conditioning use), the model predicts 82.7 TWh and 84.7 TWh of surplus and deficit respectively (figure 24). **This model is only illustrative, but it highlights that, when variable renewables form a very high share of the electricity mix, long-term, large-scale energy storage is essential to avoid massive waste of energy and complement other flexibility sources** (e.g. without load management, the deficit would be 52.8 TWh and the surplus 153.9 TWh). The penetration threshold of renewables is under debate and is, in essence, system specific (from 35% to 100% in the literature), but it is generally agreed that above 80% there will be a need for long-term, large-scale electricity storage.

**Figure 24: German residual basic load for 2050, based on 2009 data**

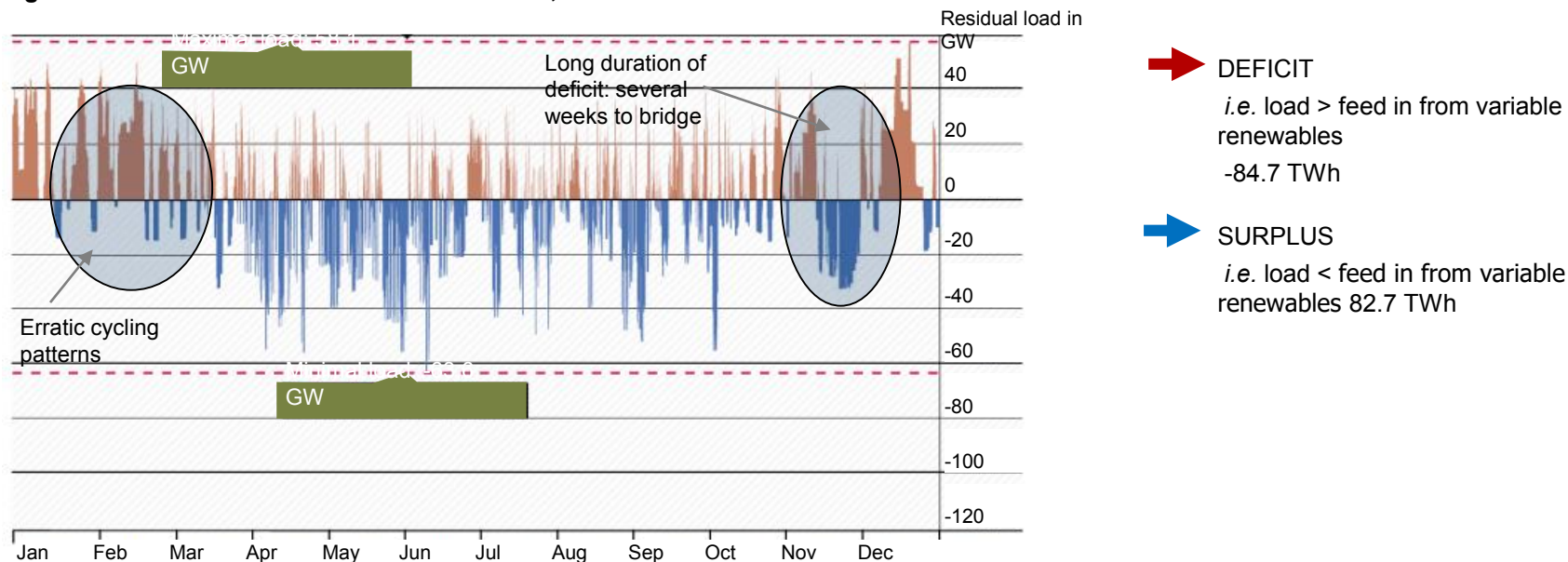

Note: Residual load with load management i.e. re-scheduling the charging of electric vehicles or the use of air-conditioning.  
Source: Fraunhofer IWES for Umwelt Bundes Amt (2010).

## 1.4 - Making the case for hydrogen conversion solutions



# Box 3: Hydrogen basics

## ID Card<sup>1</sup>

- **Name:** hydrogen, meaning “water former” in ancient Greek.
- **Chemical composition:** chemical element with atomic number one and symbol H.
- **Size:** smallest element in the Universe
- **Weight:** lightest element in the Universe
- **Age:** oldest element in the Universe that appeared after the Big Bang more than 13 billion years ago
- **Location:** most abundant element in the Universe (~75% of the universe’s baryonic mass)
- **State:**
  - At standard temperature and pressure it is gaseous and diatomic with formula H<sub>2</sub>
  - Liquid at temperatures below -259.14°C
- **Properties:**
  - Colorless, odorless, tasteless, non-toxic, non-metallic
  - Highly diffusive (density is 14 times less than that of air)
  - Flammable over a broad range of concentrations in air (4-75%)
  - Can take a negative (hydride) or positive charge in ionic compounds
  - Readily forms covalent compounds with most organic elements
  - Found most notably in combination with carbon (hydrocarbons), oxygen (water), nitrogen (ammonia)

## Figure 27: H<sub>2</sub> - history of use<sup>1</sup>

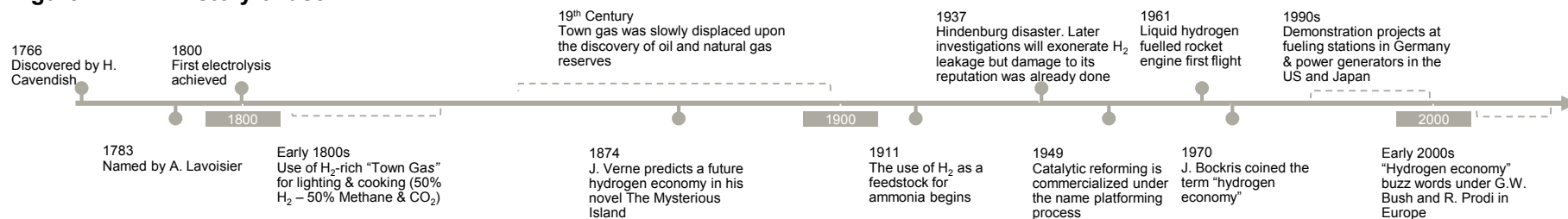

Source: A.T. Kearney Energy Transition Institute analysis, based on 1Ball et al. (2009); 2Carbon Counts (2010).

Figure 25: Estimated hydrogen production by technology in 2008<sup>2</sup>

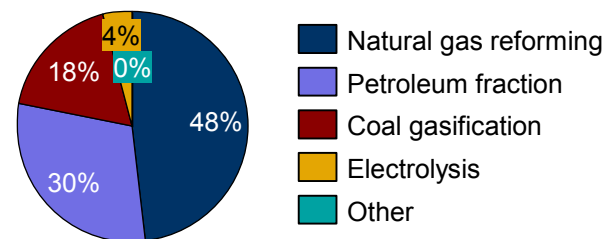
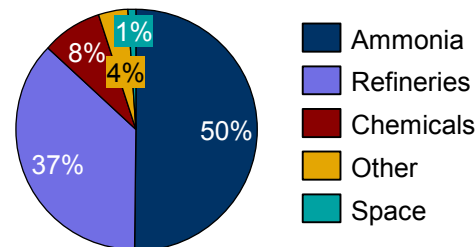

Figure 26: Estimated hydrogen consumption by end use in 2008<sup>2</sup>



# Unlike rival technologies, hydrogen-based storage involves chemical energy storage – the conversion of electricity into a new energy carrier, hydrogen, which is easier to store and transport than electricity

Hydrogen-based energy storage solutions are unique, creating a new group of storage technologies – chemical storage (figure 28). In contrast to peer electricity storage technologies, chemical storage is based on a conversion process from a carrier to another – the charging phase – where electricity produced from renewables (wind and solar), the primary energy sources, is converted into a new energy carrier – hydrogen. Although the volumetric energy density of hydrogen (kWh/l) is inferior to those of hydrocarbons, its energy density is superior to those of other bulk-storage technologies, such as pumped hydro storage.

As with conventional storage technology, electricity stored as hydrogen can be converted back into electricity during the discharge phase. Here, the main value of hydrogen solutions lies in their ability to store electricity in bulk. Besides providing a re-electrification pathway, chemical storage creates alternative uses for the stored energy. These include blending hydrogen with gas, converting it to gas, converting it to liquid fuel, valorizing hydrogen for use as a feedstock in the chemicals and petrochemicals industries, or using it as a fuel for mobility<sup>1</sup> (figure 28).

Conversion has defects associated with its virtues. It can lead to additional losses and requires investment in conversion (and re-conversion) facilities. The big questions are: under which circumstances do the virtues of chemical storage outweigh its defects? Can a system operate without it even when variable renewables are a large part of the electricity mix? And finally, can the defects be mitigated by technological progress?

Figure 28: Hydrogen-based storage system - schematic representation<sup>2</sup>

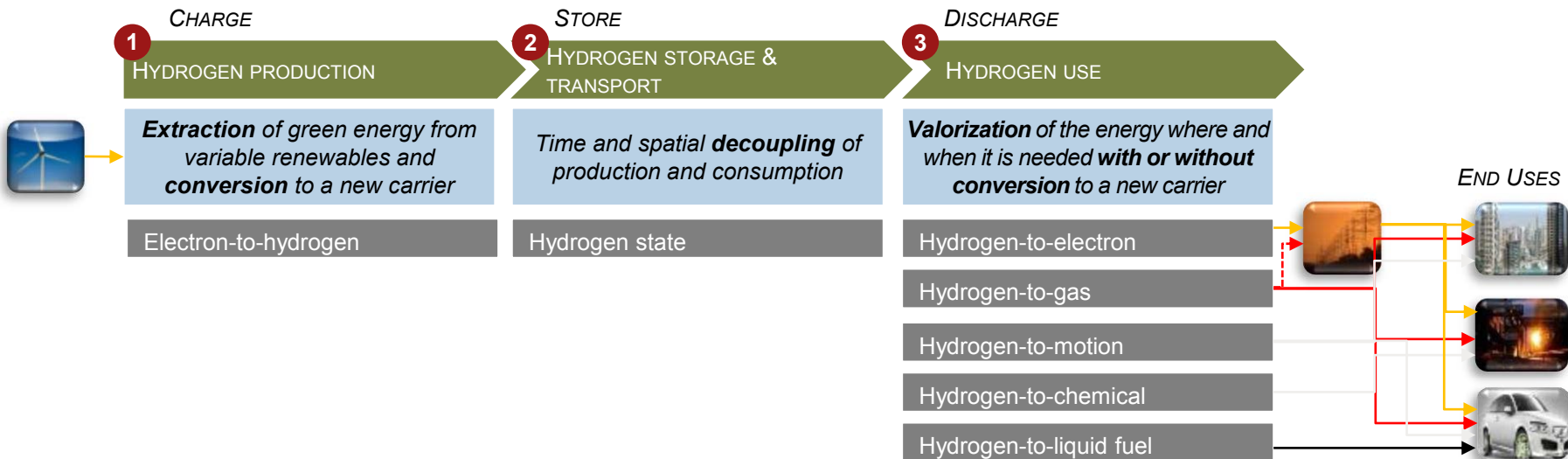

Note: Fuel cell electric vehicles involve on-board re-electrification, but is considered as a 'direct' application of hydrogen in this report; Heating is considered an end-use in the study, and hydrogen-to-heat is therefore not displayed on the graph, but included in hydrogen-to-gas, hydrogen-to-electron and hydrogen-to-liquid fuel.  
 Source: A.T. Kearney Energy Transition Institute analysis.

## The physical properties of hydrogen make it particularly suited to large-scale, long-term re-electrification applications, as well as niche markets that benefit from its discharge time and reliability

**Hydrogen-based storage solutions can, in theory, compete for the whole spectrum of storage applications**, as they decouple charging, storage and discharging, as well as benefiting from a hydrogen molecule's very high energy density per unit of mass. However, energy losses inherent in the conversion processes (power-to-hydrogen and hydrogen-to-power) are likely to limit the cycling frequency except in niche applications that leverage the unique properties of hydrogen (discharge time, energy density) and those of its underlying technologies (reliability of fuel cells for back-up power or power quality applications).

**In practice, the main applications of hydrogen-based storage solutions are expected to combine the three chief advantages of chemical storage.** (1) Very high energy density, allowing extensive storage capacity. A hydrogen molecule has an energy density per volume of 2.7-160 kWh/m<sup>3</sup> for pressures from 1 to 700 bar, compared with 0.27 kWh/100 meter elevation differential per m<sup>3</sup> of water for pumped hydro storage<sup>1</sup>, and 2-7 kWh/m<sup>3</sup> for compressed air energy storage for pressures from 20 to 80 bar (figure 29). (2) Hydrogen solutions benefit from negligible losses during the storage phase, allowing long-term storage, unlike, say, batteries. (3) Hydrogen-based technologies have the ability to react to erratic weather patterns and thus to fluctuations in storage requirements.

**Figure 29: Comparison between hydrogen and conventional storage<sup>2</sup>**  
MW, 50 Hertz data from 23<sup>rd</sup> January to 2<sup>nd</sup> February 2008<sup>3</sup>

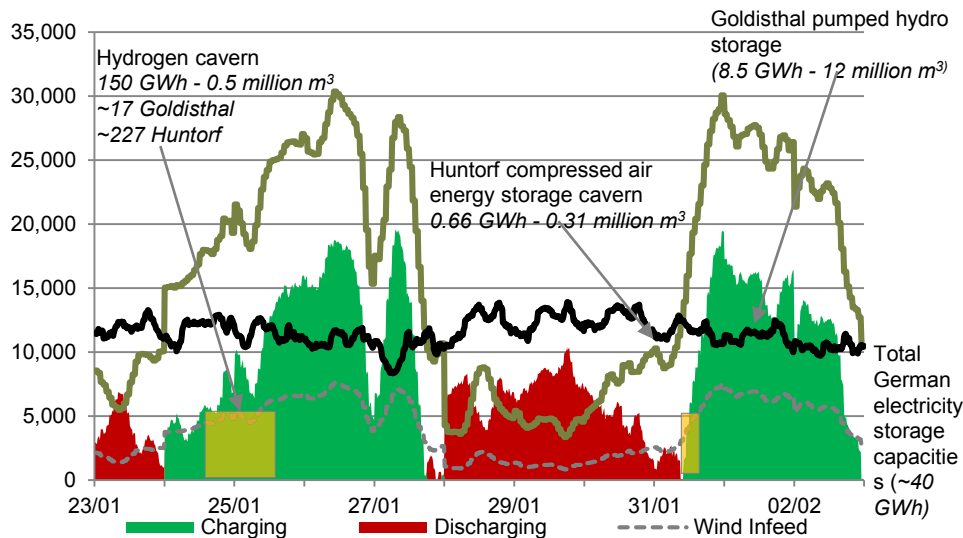

### How to read this graph?

To simulate the storage potential that would result from a fourfold increase in wind capacity in northern Germany, the wind power that was actually generated and fed into the 50Hertz grid during the week of the 23<sup>rd</sup> January to the 2<sup>nd</sup> February 2008 (the dashed grey line) has been multiplied by four: this is the Wind x 4 blue line.

The difference between this simulated wind power production (Wind x 4) and power demand (black line) in that week – demand is assumed to be the same as it was in the same week in 2008 – is depicted by the green and red areas:

- Green when simulated wind generation > demand, enabling storage charging
- Red when simulated wind generation < demand, requiring storage discharge

Finally, the yellow rectangles depict, on the same scale as storage charging/discharging potential, the energy-storage capacity of a typical hydrogen cavern and of existing storage plants in Germany: a compressed-air energy storage cavern (Huntorf), a pumped hydro storage plant (Goldisthal), as well as the country's total electricity-storage capacity. The location of the yellow rectangles is unimportant.

Note: 1For existing pumped hydro plants, the volumetric energy density of pumped hydro storage is estimated by Chen et al. (2009) to range between 0.5 and 1.5 kWh/m<sup>3</sup>; 2Wind in-feed is assumed to be four times higher with same weather pattern and load factor.

Source: 3A.T. Kearney Energy Transition Institute analysis, based on HyUnder Proceedings and 50 Hertz Data.

## Besides permitting time-shifting, converting electricity to a new energy carrier enables extracted energy to be transported through alternative infrastructure

The locations of wind and solar PV farms are constrained by the quality of the resources and tend to be concentrated far from large consumption centers (e.g. Chile's wind and hydro resources are in the south of the country and electricity is needed in the north for mining). Their integration may consequently face transmission and distribution availability and congestion issues. **Conversion to hydrogen allows multiple transport options** (figure 30), which depend on (1) where conversion and end-use transformation take place (production site, end-use site, intermediary site) and on (2) the chosen energy carrier and the availability of alternative networks (electricity, gas and hydrogen).

**Figure 30: Hydrogen-based energy transport routes**

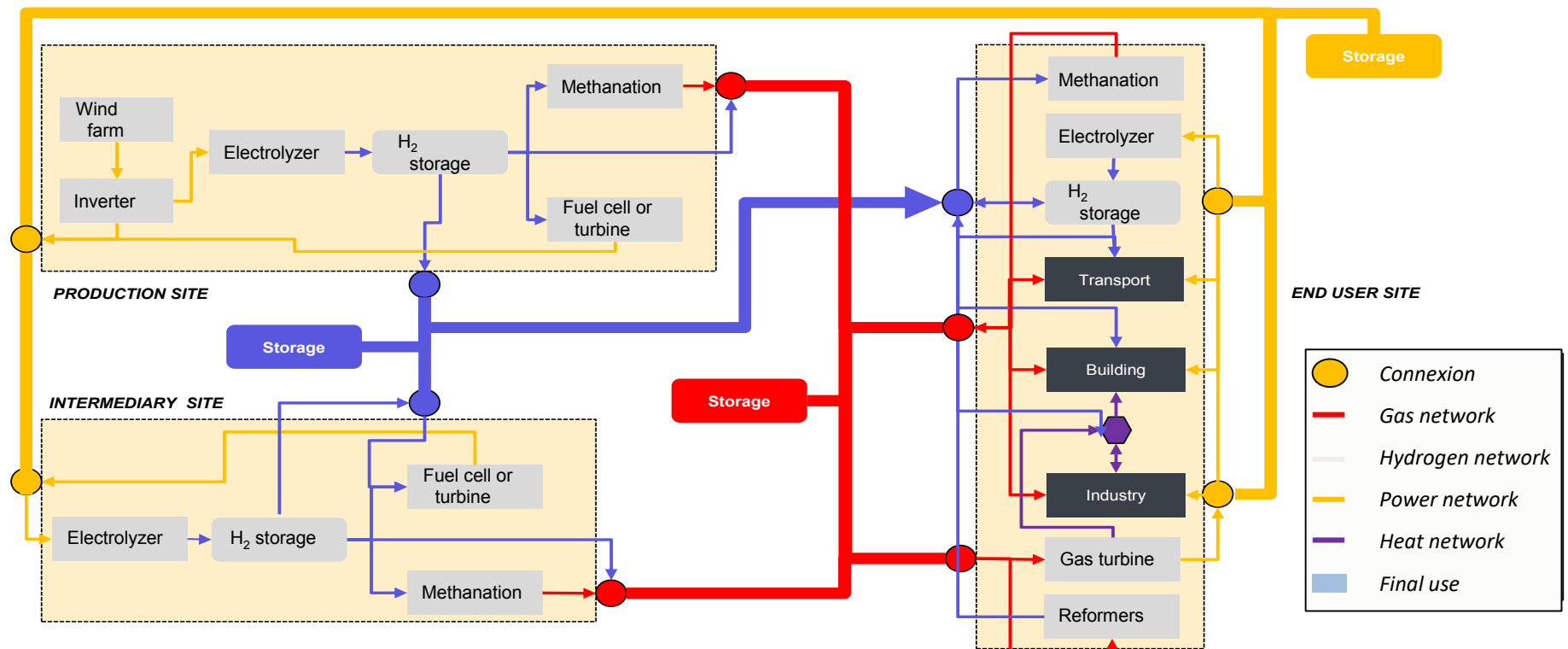

# Hydrogen-based energy storage solutions are not limited to re-electrification, due to hydrogen's versatility

**Converting electricity to hydrogen provides a bridge between the electricity carrier and the dominant molecular energy system.** In other words, it allows surplus electricity from variable renewables to go to new end-uses that are out of reach for conventional electricity storage technologies, notably mobility applications (figure 31).

**Electricity only accounts for a limited share of energy end-uses** (17% in 2009 and 26% forecast for 2050 in the International Energy Agency 2DS scenario<sup>1</sup>). Our energy systems are principally based on chemical fuels (80% in 2009 and expected to be as high as 71% in 2050) that are essentially chains of hydrogen, carbon (gasoline, diesel, natural gas) and oxygen (biomass, coal) molecules.

**Energy systems must be considered as a whole.** As the IEA advocates in the 2012 release of its *Energy Technology Perspectives*: "Efficiently integrating different sectors and technologies is critical, because technologies interact and depend on each other... In this context, systems thinking is essential to explore opportunities to leverage technology deployments within existing and new energy infrastructure". To that end, hydrogen could play a key role as a bridge between energy carriers.

**Figure 31: Energy carrier distribution by end-use, 2009 and 2050 (IEA's 2DS scenario)**

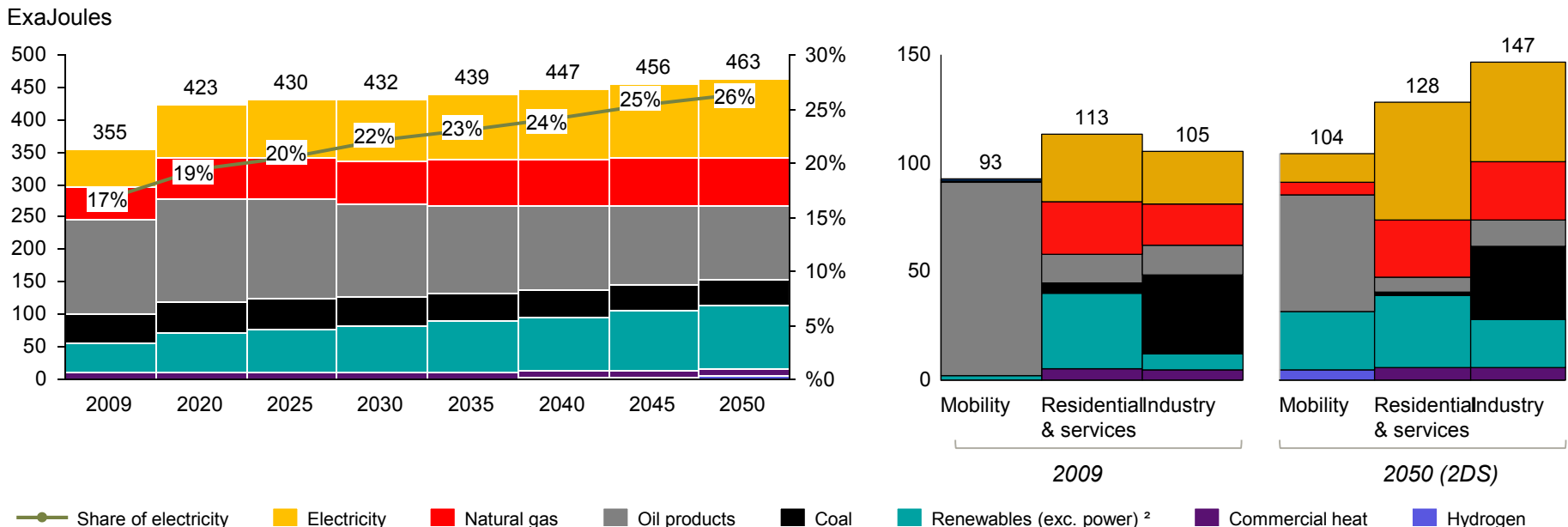

Note: <sup>1</sup>Renewables excluding power correspond mainly to biomass & waste (89% in 2009, 62% in 2050), biofuels (5% in 2009, 28% in 2050) and solar thermal (1% in 2009, 10% in 2050); <sup>2</sup>The 2DS scenario is the IEA most ambitious decarbonization scenario and corresponds to a scenario that would limit global warming to 2°C by 2050.  
 Source: A.T. Kearney Energy Transition Institute analysis; IEA (2012a).

## The three dimensions of time, space and sector flexibility, in parallel with growing intermittent penetration, have driven renewed interest in stationary storage technologies that use hydrogen as an energy carrier

**Chemical storage, exploiting hydrogen's versatility and energy value per unit of mass, is revolutionizing energy storage.** On top of providing unrivalled large-scale, long-term time-shifting ability, it also provides two additional flexibility dimensions: (i) **location shifting**, which can use not only the power grid, but also gas and hydrogen transport infrastructure and (ii) **application shifting**, which can bridge all the sub-energy systems with renewable primary energy sources – energy carriers, energy end-uses for transport, heat and industry (figure 32).

**As a result, there is a resurgence of interest in chemical storage.** While the hydrogen buzz in the 2000s was largely driven by the demand-side, with the development of fuel-cell-electric vehicles, hydrogen's new momentum seems to be being created by the supply side, where there is a push for growth in renewables.

**Hydrogen is neither a technology nor an energy source, but an energy carrier that is interconnected with numerous other energy technologies and carriers.** In the current framework, hydrogen usage, far from competing with electricity, is being driven by the production of electricity from renewables and its deployment may even be helped by the new "Golden Age of Gas".

**Figure 32: Simplified value chain of hydrogen-based energy conversion solutions**

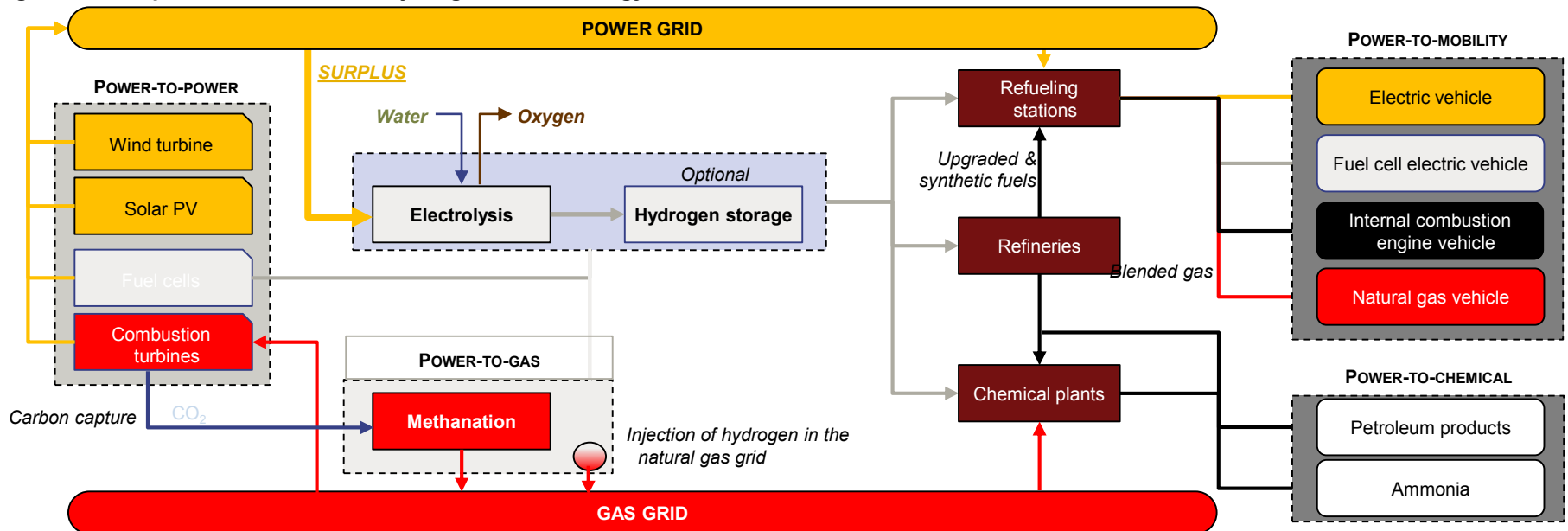

Note: Simplified value chain. End uses are non-exhaustive. Note that the power and gas grids are the main supplier to the residential and commercial end-uses (lighting, heating and cooling, cooking...).

Source: A.T. Kearney Energy Transition Institute analysis.

# Hydrogen solutions have yet to show their potential and overcome efficiency, cost and safety challenges

## Main challenges of hydrogen-based energy storage

### 1 EFFICIENCY



While Hydrogen is the most common chemical element on the planet, it is not found in its elemental form, so energy is needed to liberate it from its chemical source. Hydrogen also needs to be compressed, liquefied or absorbed into a material to become a storable and transportable commodity. Energy is lost when it is converted back into electricity in fuel cells or turbines.

Hydrogen skeptics, notably German scientist Ulf Bossel, point out the poor overall energy balance of hydrogen from well to wheels. They argue that, in a world dominated by renewable energy of a physical nature (heat from concentrated solar power and geothermal power, solar radiation for solar photovoltaic, mechanical energy in the cases of wind, waves and hydro), it is more efficient to distribute energy directly in the form of physical energy, without introducing intermediate chemical carriers.

Hydrogen would make sense as a complement and enabler of renewable electricity, due to its unique properties. Efficiency within the various steps of the hydrogen value chain is crucial to minimize the energy wasted and make it commercially viable.

### 2 INVESTMENT COSTS



Efficiency affects the operational costs [opex] of hydrogen production, but the large initial investment needed is also a big inhibitor to the development of hydrogen-based energy-storage technologies. Hydrogen energy-storage projects require high capital expenditure [capex] throughout the value chain: production (electrolyzers), storage (compressors, storage tanks, underground cavern), transport (trucks, pipelines), and end-use.

Like all new technologies, hydrogen-based energy storage is facing the 'valley of death' in its maturity curve. High capital requirements will be needed before the learning curve is completed and mass production results in lower costs. First-of-a-kind demonstration plants are high-risk endeavors. Competition with other technologies for capital is also likely to be an issue, as development is at the mercy of variable renewable penetration that shifts energy models from opex (e.g. gas power plants driven by marginal costs of production) to capex (no fuel cost).

The "chicken-and-egg" dilemma of hydrogen-use has been one of the main impediments to realizing the potential of the hydrogen buzz of the 2000s: constructing hydrogen refueling stations and pipelines is not worth the investment to serve just a small number of vehicles, but these hydrogen distribution facilities are a pre-requisite if fuel-cell-electric vehicles are to take off. While stationary applications of hydrogen-based storage could be incorporated into existing networks (gas and power), investment costs would remain an issue, especially if efficiency remains low (e.g. utilization vs feed-in costs; efficiency gains vs increases in investment costs).

### 3 SAFETY



For the public, hydrogen has long been associated with the Hindenburg disaster in 1937 (even though investigations found it was not to blame) and it is true that its properties do raise safety concerns. Like fossil fuels, hydrogen entails (i) flammability and (ii) detonability. Its concentration range for flammability is very broad, if mixed with air at concentrations from 4 % to 75%. The minimum energy required for ignition is also very low, around 15 times less than that of methane. While methane or gasoline detonate with leaner mixtures (18% for hydrogen vs. 6.3% for methane), hydrogen can detonate with much richer mixes (up to 59% for hydrogen). Besides, contrary to unlike most other gases, H<sub>2</sub> compressed at ambient temperature heats up when it expands to atmospheric pressure (Joule-Thomson Effect). On its own, this is unlikely to lead to spontaneous ignition, but has to be borne in mind due to its possible combination with other effects. Finally, hydrogen also carries the risk of (iii) embrittlement of handling vessels. Because of its very small molecule size, hydrogen easily migrates along micro-cracks in vessels. More generally, its size and low density leads to leaks and diffusion. Hydrogen is odorless and its flame is practically invisible in daylight, making leak detection more difficult.

A set of international codes and standards is thus needed, as well as education about the proper and safe handling of hydrogen. Ensuring safety is a pre-requisite to achieving public acceptance, which can be facilitated by communicating with the public and considering their opinions.

# Sources: section 1

- Air Liquide (2012), *“Financing Hydrogen Projects – Business cases and political support?”*, Proceedings of the IPHE Conference in November 16<sup>th</sup> Sevilla Workshop
- Ball et al. (2009), *“The Hydrogen Economy – Opportunities and Challenges”*, Michael Ball, Martin Wietschel, Cambridge University Press
- Bennaceur et al. (2005), *“Hydrogen: A Future Energy Carrier?”*, Kamel Bennaceur, Brian Clark, Franklin M. Orr Jr, T.S. Ramakrishnan, Claude Roulet, Ellen Stout, Oilfield Review pp. 30-41
- Carbon Counts (2009), *“CCS Roadmap for Industry: High-purity CO<sub>2</sub> sources”*, Paul Zakkour, Greg Cook
- Electric Power Research Institute – EPRI (2010), *“Electricity Energy Storage Technology Options - A White Paper Primer on Applications, Costs, and Benefits”*
- Etogas (2012), *“Meeting A. T. Kearney Energy Transition Institute – Etogas”*
- Fraunhofer Institut für Windenergie und Energiesystemtechnik für Umwelt Bundes Amt (2010), *“2050: 100% - Energie Ziel 2050: 100% Strom aus erneuerbaren Quellen”*
- Hydrogenics – (2012), *“Power-to-Gas: Technology and Business Model Progress”*, Proceeding of the IPHE Conference in November 16<sup>th</sup> Sevilla Workshop
- International Energy Agency – IEA (2012a), *“Energy Technology Perspectives 2012”*
- International Energy Agency – IEA (2012b), *“Renewable Energy – Medium Term Market Report 2012”*
- International Energy Agency – IEA (2012d), *“World Energy Outlook 2012”*
- International Energy Agency – IEA (2011a), *“Harnessing Variable Renewables - A guide to balancing challenge”*
- International Energy Agency – IEA (2011b), *“Deploying Renewables 2011 – Best and Future Policy Practice”*
- International Energy Agency Energy Conservation through Energy Storage – IEA ECES (2012), *“Energy storage for the integration of renewable electricity”*
- Intergovernmental Panel on Climate Change – IPCC (2011), *“Special report on renewable energy”*
- Massachusetts Institute of Technology – MIT (2011), *“The Future of the Electric Grid”*
- New Energy World Industry Grouping – NEW IG (2012), *“Study on the trends in terms of investments, jobs and turnover in the Fuel cells and Hydrogen sector”*
- National Renewable Energy Laboratory – NREL, Download from the Dynamic Maps, GIS Data, & Analysis tool webpage (<http://www.nrel.gov/gis/wind.html>)
- Pöyri – (2009), *“Impact of intermittency: how wind variability could change the shape of the British and Irish electricity markets”*
- Réseau de Transport d'Électricité Data – Download from Website: (<http://www.rte-france.com/fr/developpement-durable/eco2mix/telechargement-de-donnees>)
- Ueckerdt et al. (2012), *“Variable Renewable Energy in modeling climate change mitigation scenarios”*, Potsdam Institute of Climate Impact Research
- United States Department of Energy – US DoE (2011), *“Energy Storage Program Planning Document”*
- United States Energy Information Administration – EIA (2012), *“Electric Power Annual 2010”*
- United States Energy Information Administration – EIA (2012), Download from Coal Stocks (<http://www.eia.gov/coal/data.cfm#stocks>), Natural Gas storage (<http://www.eia.gov/naturalgas/data.cfm#storage>), and Petroleum Stocks (<http://www.eia.gov/petroleum/data.cfm#stocks>)
- Ulf Bossel (2006), *“Does an hydrogen economy makes sense?”*, Proceeding of the Institute of Electrical and Electronics Engineers Vol. 94, pp. 1826-1837
- 50 Hertz Data – Download from Website: Archive Wind Power (<http://www.50hertz.com/en/1983.htm>) and Archive Photovoltaics (<http://www.50hertz.com/en/PV.htm>)

## Section 2 - Techno-economic analysis



## 2.1 - Electron-to-hydrogen: water electrolysis



## Summary & key findings: section 2.1

1. **Water electrolysis is the process of using electrical energy to split water into its chemical constituents** (hydrogen [H<sub>2</sub>] and oxygen [O<sub>2</sub>]), thereby converting electrical energy into chemical energy. Hydrogen is an energy carrier that can be stored or transported before use. Its chemical energy content is measured by its Higher Heating Value [HHV]. Electrolysis plants are composed of stacked electrolyzer cells, and the balance of plant [BoP].
2. **Although continuous-load water electrolysis is a mature technology, hydrogen-based electricity storage requires, first and foremost, a flexible electrolyzer that is able to withstand variable loads.** Three types of electrolyzer are being developed for this purpose: alkaline, proton exchange membrane [PEM] and solid oxide electrolyzer cell [SOEC].
  - **Alkaline** has long been a commercial technology and is undergoing performance optimizations to improve operational flexibility and reduce maintenance costs. It is the most common option for systems larger than 200 kW, yet its complex design offers limited cost-reduction potential.
  - **PEM** is a promising alternative to alkaline technology, although it is still in the early deployment phase and can only compete with alkaline in small applications. It is highly flexible, easier to operate with a pressurized supply of hydrogen and has a simple design, creating considerable potential for cost reductions if the use of noble catalyst metals can be avoided or reduced.
  - **SOEC** is a groundbreaking technology, at the R&D stage. It could co-electrolyze water & CO<sub>2</sub> to produce syngas (H<sub>2</sub> + CO) and oxygen at very high rates of efficiency. SOEC could also be used in electrolyzers or fuel cells, as required. It is potentially cheap to manufacture, but cell lifetime is, at present, far from acceptable for commercial purposes.
3. **Electrolyzer R&D aims to optimize both capital costs per kW and energy efficiency.** This is a challenge, since for any given electrolyzer, energy efficiency decreases with the desired hydrogen-production rate. Operating an electrolyzer with an H<sub>2</sub> production rate above the manufacturer's recommendation (= nominal value) is technically feasible and would reduce investment costs per kW. However, this would reduce cell efficiency and lifetime. Significant improvements in electrolyzer efficiency have been made in the past decade; under nominal conditions, PEM and Alkaline can now attain 78% efficiency. The next priority is to lower manufacturing costs, which have a greater impact than efficiency on the levelized cost of hydrogen [LCOH], if the electrolyzer is operated highly discontinuously.
4. **Electrolyzer cannot yet compete with conventional hydrogen production processes**, but should rely on two key parameters to improve competitiveness:
  - Limited economies of scale thanks to the modular nature of electrolyzer plants: A decentralized 1 MW electrolyzer plant is only ~5% more costly per MW than a centralized 50 MW one. Electrolyzers are therefore closer to competitiveness with alternative production processes for decentralized applications.
  - Flexible utilization: Operated continuously, grid-connected electrolyzers are unable to compete with steam methane-reforming, even for decentralized production. Discontinuous operation should reduce the LCOH produced by: 1) arbitrating on grid electricity price variations (using in priority off-peak electricity prices) and 2) participating in grid stability mechanisms (being rewarded for adjusting electricity withdrawal upwards or downwards, on demand). However, at the moment, electricity price variations in most European markets are too small to enable significant cost reductions in hydrogen production..
5. **The main parameters that could reduce the LCOH production** are therefore, in decreasing order of importance: reductions in electricity input prices, reductions in the capital costs of electrolyzers, greater electricity-price volatility and the introduction of mechanisms to reward short-term grid-stability services or long-term storage services. The ability to sell by-produced oxygen or to valorize excess heat will also have an impact.

# Large-scale electrolyzers capable of tolerating variable loads are prerequisites for hydrogen-based electricity storage

Water electrolysis is the only technology that can store electricity in the chemical bonds of hydrogen molecules ( $H_2$ ). It is a mature concept (figure 33): the capacity of individual electrolyzer plants varies widely, ranging up to a maximum of 100 MW. Cumulative worldwide generation capacity amounts to about 8 GW and accounts for about 4% of the hydrogen consumed globally. Virtually all of the rest is produced from fossil fuels. Annual market for electrolysis is still very limited, ranging around 100 MW per year: since the 1970s, steam methane reforming plants have generally been preferred to water electrolysis in regions that do not have large hydroelectricity sources. Indeed, **most of the installed electrolyzer capacity has been built to convert cheap electricity from hydraulic power plants into hydrogen for fertilizer production. As a result, these electrolyzers have been designed to run continuously at full load, prioritizing energy efficiency over capital costs and flexibility.**

Over the past decade, following the rapid increase in the capacity of variable renewables, there has been an increasing focus on advanced electrolyzer R&D. More dispatchable (flexible and reactive) electrolyzer plants with lower investment costs are required in order to monetize temporary excesses of electricity from intermittent renewable generation sources or to provide grid-regulation services.

From a technical point of view, electrolyzers are “ready”. The cheapest commercial plants cost \$800 per  $kW_{ch}$  of  $H_2$ , the most efficient reach 78% $_{HHV}$ , and the most dispatchable have a ramping rate of about 1 second from ~0% to 100% load. Three main types of electrolyzers – Alkaline, proton exchange membrane [PEM], and solid oxide electrolyzers [SOEC] – are being developed and are at various stages of maturity. All of them are faced with the challenge of simultaneously optimizing costs, efficiency and flexibility.

Figure 33: History of water electrolysis

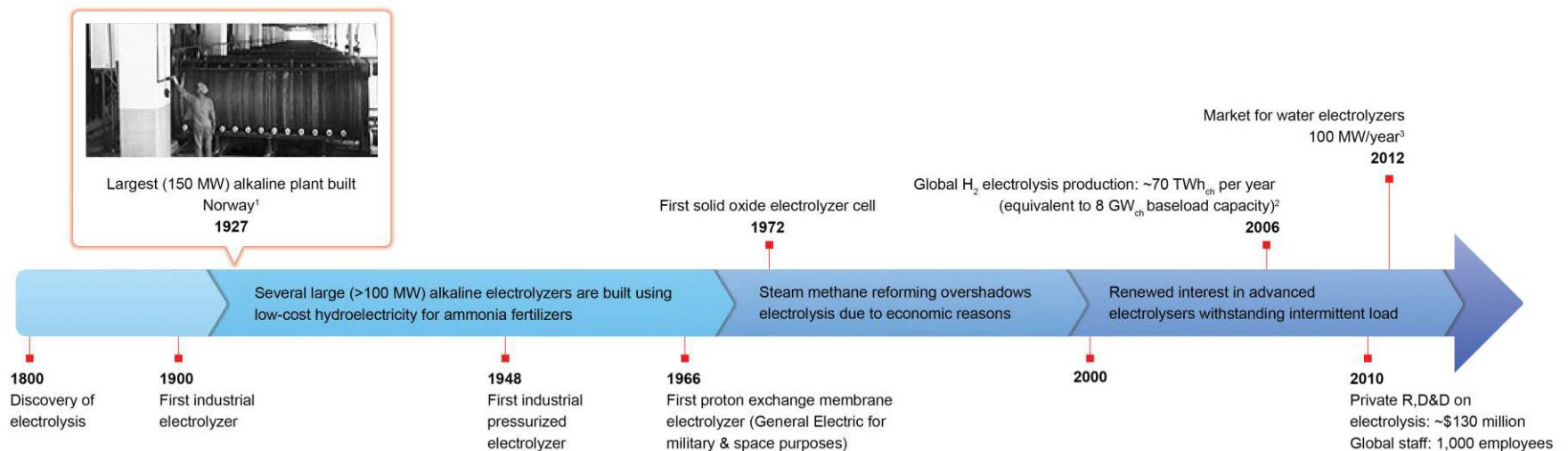

Note: The plant built in 1927 by Norskhydro consisted of 150 alkaline stacks of 1MW each. It was used to produce hydrogen from nearby hydroelectric plant to produce ammonia for fertilizers. Source: Image courtesy of: 1Norsk H Hydrodro; 2SRI (2007); 3FuelCellToday (2013).

## Box 4: Energy units

**Energy** is a quantity that exists in many forms, but can be measured by a single common unit: the watt-hour (Wh). One watt-hour is the cumulated energy generated during one hour at a **power** of one watt (W). Energy is never destroyed, but converted from one type to another: Throughout the report, the type of energy (and power) will be specified by a subscript attached to the unit:

- **Wh<sub>th</sub> refers to thermal energy.** This is, for instance, the energy contained in the hot steam generated by a nuclear power plant that will be converted into mechanical energy in the steam turbine. It is roughly proportional to the mass of matter multiplied by its temperature when measured in Kelvin.
- **Wh<sub>mec</sub> refers to mechanical energy.** This is the energy associated with the motion and position of an object; for instance, the energy contained in the rotation of a turbine, which is then converted into electrical energy in a generator. It is equal to the sum of potential energy and kinetic energy.
- **Wh<sub>e</sub> refers to electrical energy** (or electricity). This is, for instance, the electricity generated by a hydrogen fuel-cell and is equal to the electric power delivered (current times voltage) multiplied by the amount of time.
- **Wh<sub>ch</sub> refers to the chemical energy** of a fuel. That is to say, the heating value contained in the molecule and released upon combustion with oxygen. For hydrogen, the combustion reaction is:  $\text{H}_2 + \frac{1}{2} \text{O}_2 \rightarrow \text{H}_2\text{O} + \text{energy}$ . Apart from in the case of fuel cells, where the energy released is electrical, combustion generally results in the release of thermal energy. Theoretically, in perfectly insulated engines, all thermal energy is contained in the temperature of the water produced. Any conversion of this thermal energy into useful energy (such as mechanical energy) will lower the water temperature by a value that depends on the efficiency of the process. Two different heating values of the fuel therefore co-exist:
  - **Higher Heating Value [HHV]** assumes all heat from the water can be recovered by restoring the water temperature to its initial ambient state. It considers all energy absorbed by the H<sub>2</sub>O molecule to be potentially useful and is, therefore, the theoretical heating value of hydrogen. **Throughout this report Wh<sub>ch</sub> refers to Wh<sub>HHV</sub> unless stated otherwise.** Quantities of hydrogen are expressed in chemical energy content relative to higher heating value (Wh<sub>ch</sub>). Other frequently used units are weight (1 kg<sub>H<sub>2</sub></sub> = 39.39 kWh<sub>ch</sub>) and normalized volume at ambient conditions: 25°C, 1bar (1 Nm<sup>3</sup><sub>H<sub>2</sub></sub> = 3.3 kWh<sub>ch</sub>); and
  - **Lower Heating Value [LHV]** assumes that the water component of a combustion process is in vapor state at the end of combustion, and that the heat content from the condensing vapor is not recovered/useful. In other words, it considers that water heated to a temperature below 150°C is useless (the arbitrary value of 150°C is based on the fact that most burners / combustion engines reject water vapor at around 150°C). LHV is often used to provide a benchmark for thermo-electrical processes because it embellishes efficiency figures. However, it has little relevance in the cases of fuel cells and combined heat & power systems, and even less in non-combustion conversions, such as H<sub>2</sub>-to-chemicals, which can make use of most of a fuel's chemical energy. Hydrogen's HHV is 18.2% above its LHV (*i.e.* HHV/LHV = 1.182 and LHV/HHV = 0.846).

**Energy efficiency** of a conversion process is the dimensionless ratio, in %, of useful energy output divided by energy input. For processes with multiple types of energy input and/or outputs, it is important to specify which energy efficiency is referred to. For instance, the electricity-to-hydrogen energy efficiency of a high-temperature, combined heat & power electrolyzer is much lower than its overall energy efficiency, which is  $\frac{(\text{H}_2 + \text{recycled heat})_{\text{output}}}{(\text{Heat} + \text{Power})_{\text{input}}} = 100\% - \text{non-recycled losses}$ . Throughout this report, the Electricity/H<sub>2</sub> conversion energy efficiencies of electrolyzers and fuel cells are expressed as a percentage of the higher heating value of the hydrogen: %<sub>HHV</sub> = %. It is important to note that the round-trip efficiency of power-to-H<sub>2</sub>-to-power systems is unaffected by the convention selected for the heating value of hydrogen.

**Exergy** is the part of the total energy that can be converted into mechanical energy with the best theoretical machine. Exergy < Energy and the ratio Exergy/Energy (<1) is a measure of the *quality* of energy produced. Mechanical and electrical energy have the best quality: Energy = Exergy. Thermal energy's quality is null at ambient temperature, and increases with temperature (T), equaling  $1 - \frac{T_{\text{ambient}}}{T}$ . Chemical energy's quality depends on the temperature of combustion but is generally very close to 1 for H<sub>2</sub> and hydrocarbons fuels. Exergy is a useful concept in heat & power applications, where the by-product of low-temperature heat has a relatively low quality and value.

# Water electrolysis converts electricity and water into hydrogen and oxygen by means of electrolyzer cells

- The water electrolysis reaction  $\text{H}_2\text{O} + \text{electrical energy} \rightarrow \text{H}_2 + \frac{1}{2} \text{O}_2$  consists of using electrical power to split water molecules into their separate components (figure 34). An electrolyzer cell consists of two conductive metallic electrodes (anode and cathode) separated by an electrolyte. Direct current provides a flow of charge into the electrodes in the form of electrons ( $e^-$ ) and through the electrolyte in the form of an ion called the charge carrier ( $X^-$ ), which can take various forms, depending on the type of cell. The  $\text{H}_2$  production rate is directly proportional to the intensity of the current  $I$  (flow of charge per unit of time) or current density ( $i$ , intensity per electrode surface area). The efficiency of the cell  $\eta_{\text{cell}}$  is therefore inversely proportional to the voltage  $V$ , as long as the only power input is electric (power =  $I * V = \text{H}_2 \text{ flow} / \eta_{\text{cell}}$ ). A fundamental trade-off takes place between the efficiency of the cell and its  $\text{H}_2$  production rate.
- The optimal operating voltage  $V$  (and related intensity  $I$ ) that defines the nominal operation mode is set arbitrarily by the operator, depending on his preference between efficiency and  $\text{H}_2$  production rate (figure 35). Operating at  $V$  below the reversible potential ( $E_{\text{rev}}$ ), no electron has enough energy to split the water molecules. Intensity is null, as well as efficiency. Operating at  $V$  above  $E_{\text{rev}}$ , electrolysis can take place. Current flows and the cell's internal resistance creates heat losses that increase with voltage, reducing its efficiency. However, the water splitting reaction is endothermic, so that the cell tends to cool and electrolysis stops if no heat is provided. Two operating modes therefore exist:
  - Below the thermo-neutral potential  $E_{\text{tn}}$ , resistive heat losses do not cover the requirements of the reaction and additional, external heat is needed. Efficiency is 100% if the right amount of heat is provided, but the  $\text{H}_2$  production rate is very low, requiring expensive, oversized cells.
  - Above  $E_{\text{tn}}$ , resistive heat losses exceed the requirements of the reaction. Efficiency is therefore inversely proportional to voltage:  $\eta_{\text{cell}} = E_{\text{tn}} / V$ . The nominal operating mode is generally set in this range. The operator will vary intensity within this range in order to modulate the  $\text{H}_2$ -production rate: there will be a minimal load, but nothing to prevent the operator from pushing the intensity above the nominal value (manufacturers' spec) to increase  $\text{H}_2$  production temporarily, at the expense of efficiency<sup>2</sup>

Figure 34: Schematic principle of a water electrolysis cell

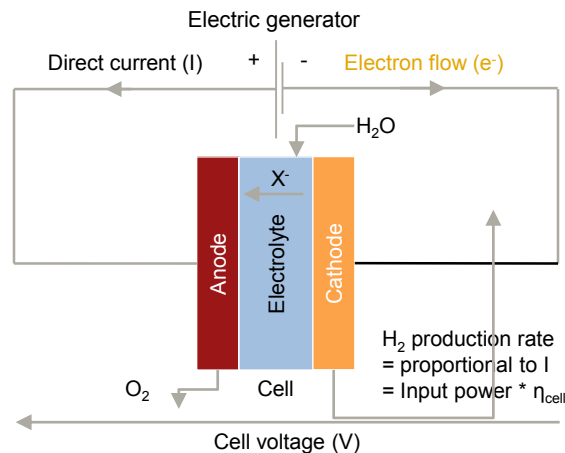
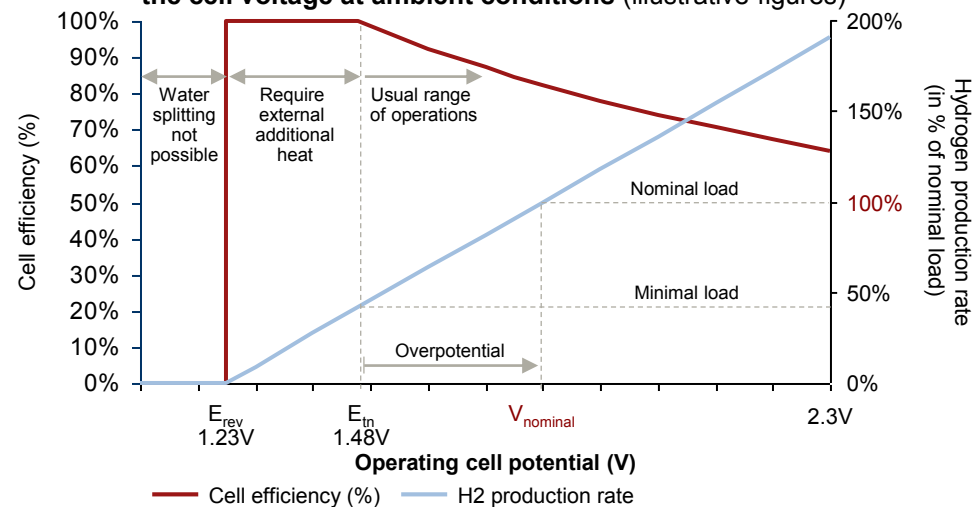

Figure 35: Cell efficiency<sup>1</sup> and  $\text{H}_2$  production rate as a function of the cell voltage at ambient conditions (illustrative figures)



1. In reality, parasitic current losses divert some electrons away from water splitting. The  $\text{H}_2$  production rate is proportional to the intensity of the current, but is reduced by a current-efficiency factor. The latter is close to 100% in nominal operating mode, but is a decreasing function of current density, especially when close to 0. It has a low impact at low intensities and voltages (i.e. close to  $E_{\text{rev}}$ ); 2 and generally at the expense of cell lifetime.

# An electrolyzer plant consists of electrolyzer stack(s) and the balance of plant

- **Electrolyzer cells** are very small (less than 5 kW), since the surface area of electrodes is limited by mechanical constraints (usually below 1 m<sup>2</sup>).
- **Electrolyzer stacks** (figure 36), which group up to a hundred cells together, generally in series (bipolar configuration), or occasionally in parallel (unipolar), are the basic products commercialized by electrolyzer manufacturers. Manufacturing constraints and voltage limitations across the stack limit the number of cells per stack.

- The simplest **electrolyzer plant** (or system) is made of an electrolyzer stack and the balance of plant [BoP].
- Larger plants (figure 37) are built by adding electrolyzer stacks in parallel, reducing the share of balance of plant of total capital costs (from 45% for one stack down to 35% for 50 stacks)<sup>1</sup>. Having multiple stacks in parallel also facilitates maintenance scheduling and increases plant flexibility and reliability. However, building multiple stacks in parallel is more expensive than building a single stack of equivalent capacity.
- The ability to increase the capacity of an individual stack is therefore of crucial importance in developing cost-efficient electrolyzer plants at the scale of tens of MW.

**Electrolyzer Key Performance Indicators:**  
**Investment costs (\$/kWch); Energy efficiency  $\eta$  (%); Capacity (kWch); Lifetime (h); Flexibility (min. load factor in %); and Reactivity (ramping rate in W/s)**

**Figure 36: Schematic of an electrolyzer stack**  
10 cells in bipolar configuration

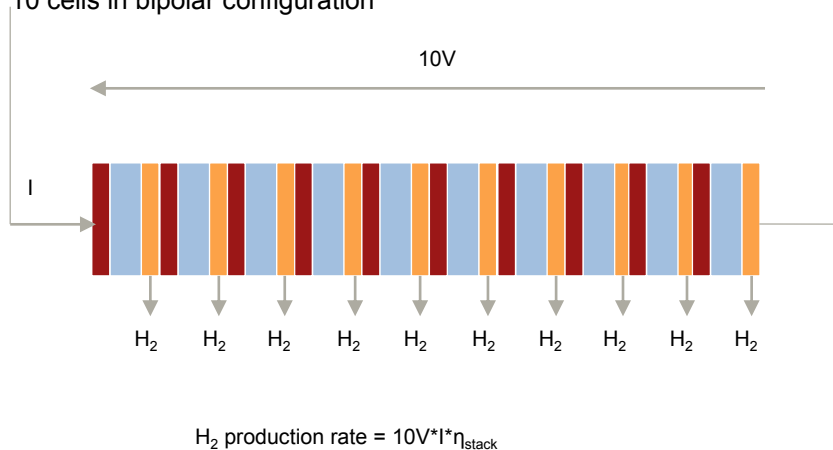

**Figure 37: Schematic of an electrolyzer plant<sup>2</sup>**  
Non-pressurized, Proton Exchange Membrane [PEM] system

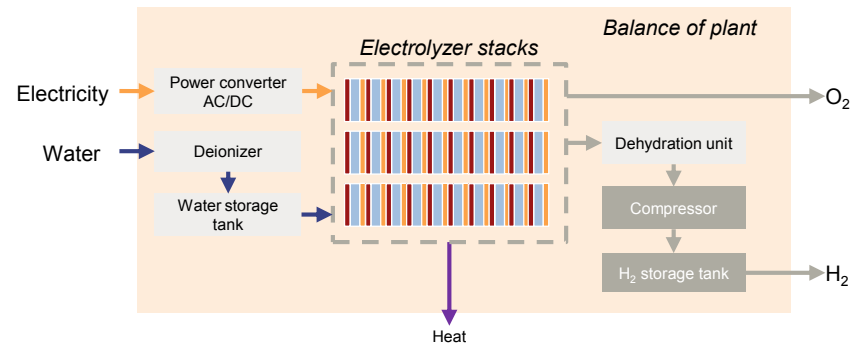

1. US DoE H2A analysis model for alkaline electrolyzer; 2Unlike other parts of the balance of plant that are integrated into any electrolyzer system, compressor and H2 storage tanks are optional.  
 Source: A.T. Kearney Energy Transition Institute analysis.

# Optimal operating conditions in electrolyzers (concerning temperature, pressure and current intensity) arise from a trade-off between efficiency, manufacturing costs and lifespan

For a given electrolyzer, operating conditions have various effects on efficiency, lifetime and investment costs per unit of capacity installed. These are summarized in figure 39.

- **Current intensity** improves a cell's hydrogen production rate at the expense of efficiency. Current density is often used to normalize intensity per surface of electrode.
- **Temperature** significantly improves electrolyzer efficiency, generally at the expense of the durability of materials used and stack lifetime. Below the boiling point of water, increasing the temperature slightly reduces the total energy required. At higher temperatures a significant part of the total energy required can be provided in the form of heat, which can be generated by recycling the cell's resistive losses.
- **Pressure:** Operating electrolyzer stacks at high pressure requires almost no more energy than under ambient conditions. Therefore, this procedure is more efficient at the overall plant level than compressing hydrogen after electrolysis. Nonetheless, pressurized operation creates more complex engineering challenges and requires more durable materials, which can increase manufacturing costs.

**Figure 38: Thermodynamic performances (voltage vs. current density), at different operating pressures and temperatures for a given cell**

*Influence of cell temperature*

*Influence of cell pressure*

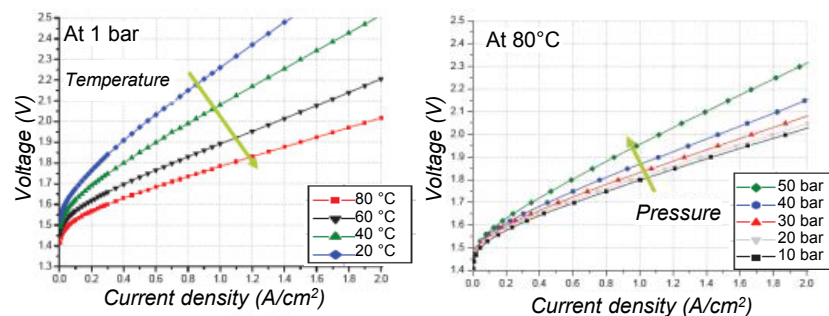

- Operating cell voltage – which is inversely proportional to cell efficiency – increases with current density, decreases with temperature, and is only slightly affected by pressure.

**Figure 39: Qualitative effects of operating conditions on electrolyzer performance**

Effect on performance	Operating condition	Current density	Pressure	Temperature
<b>Effect on system efficiency (or operating costs)</b>		Increases cell operating voltage	Saves compression energy at system level	Lowers operating voltage of cell
<b>Effect on investment cost per kW</b>		Decreases costs proportionally to current density	Avoid the need for mechanical compressor, but raises engineering challenges	Requires more robust materials
<b>Effect on stack lifetime (or maintenance costs)</b>		Can destabilize the stack if pushed to the limit	Can destabilize the stack if pushed to the limit	Speeds up degradation of materials

Negative effect  Positive effect

## Three different types of electrolyzers are competing, at different levels of maturity

Three main types of electrolyzers have been developed, differentiated by their cell electrolyte: alkaline, proton exchange membrane [PEM] and solid oxide electrolyzer cell [SOEC] by order of technical maturity (figure 41).

In terms of cell layout, PEM and SOEC are simple, compact and built around a solid membrane without any moving parts. In contrast, alkaline cells are made of cheap materials, but have a large cell area and a complex electrolyte circulation loop.

In terms of electrochemical performances – reflected by their operating voltage as a function of the operating current density (figure 40) – PEM electrolyzers can operate at much higher current densities than alkaline ones, and are therefore more compact and potentially cheaper to build (smaller cell area decreases manufacturing costs per kW). SOECs hold the most promising thermodynamic potential, as a result of their ability to operate at very high temperatures: as shown in (figure 40), they can operate below their thermo-neutral potential  $E_{tn, steam}$ , reaching 100% efficiency, in theory, at a relatively high current density.

The main thrust of R&D in alkaline cells is improving electrochemical performance by reaching higher temperatures, and improving flexibility and reactivity. Improvements to PEMs mainly concern the reduction of manufacturing costs. SOECs are still a laboratory-stage technology and need to demonstrate acceptable levels of cell degradation and durability.

Figure 40: Typical electrochemical performances of electrolyzers<sup>1</sup> (order of magnitude only)

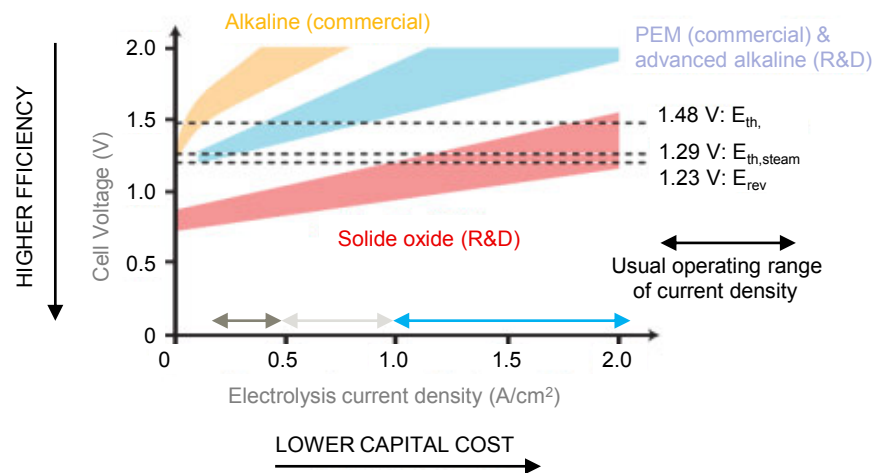

Figure 41: Comparative performance of alkaline, proton exchange membrane and solid oxide electrolyzer cells<sup>2</sup>

	Alkaline	PEM	SOEC
<b>Electrolyte</b>	KOH liquid	Polymer membrane	Ceramic membrane
<b>Charge carrier</b>	OH <sup>-</sup>	H <sup>+</sup>	O <sup>2-</sup>
<b>Temperature</b>	70-90°C	60-80°C	700-900°C
<b>Current density</b>	0.3 – 0.5 A/cm <sup>2</sup>	1 - 2 A/cm <sup>2</sup>	0.5 – 1 A/m <sup>2</sup>
<b>Technical maturity</b>	Commercial	Initial commercial	R&D
<b>Max stack capacity (kW<sub>ch</sub>)</b>	3,000	100 today, ~1,000 in Q2 2013	10 today, potential TBD
<b>System capital costs (\$/kW<sub>ch</sub>)</b>	850 today, 550-650 expected <sup>4</sup>	1,000-2,000 today, 760 expected <sup>4</sup>	200 expected at 500 MW/yr production <sup>5</sup>
<b>System efficiency at beginning of life (% HHV)</b>	68-77% today, potentially up to 82% at 300 mA/cm <sup>2</sup>	62-77% today, potentially up to 84% at 1,000 mA/cm <sup>2</sup>	89% (laboratory), potentially above 90%
<b>Annual degradation<sup>3</sup></b>	2-4%	2-4%	17% (1,000h test only)
<b>System lifetime (years)</b>	10-20 proven	5 proven, 10 expected	1 proven, potential TBD

3. Power consumption increase per year in baseload utilization; 4. Expected by 2025 according to assumptions from U.S. DoE H2A model;

5. Expected if industrial production capacity is reached

Source: 1. Reproduced from Graves et al. (2010); 2. Detailed in following slides.

# Alkaline is the most mature electrolyzer technology and can be produced for large-scale applications, but its complex cell design offers limited power density and, therefore, limited potential for cost reduction

## Status and outlook

Alkaline electrolysis (figure 42) is one of the easiest methods of hydrogen production. It is the most mature electrolyzer type (figure 43) and the cheapest to manufacture. It has been used since the 1920s to produce pure hydrogen in large quantities for the manufacture of chemical fertilizers, when electricity is inexpensive. Its thermodynamic performance is relatively poor, but great improvements in flexibility and reactivity have been made in the past decade. This has enabled alkaline electrolysis to take advantage of electricity price arbitrage opportunities on the spot market, but not to provide control reserves on the balancing market. It is the currently the most attractive electrolyzer for capacities larger than 250 kW, but its cost-reduction potential could be limited. Whether alkaline electrolyzers remain the most competitive technology depends on progress with other, less mature competitors. R&D is focused on lowering manufacturing costs, raising operating pressure, and improving reactivity and flexibility.

**Figure 42: Alkaline cell schematic<sup>3</sup> (left) and real 2.7 MW<sub>ch</sub> stack<sup>4</sup> (right)**



- Two electrodes (7) are submerged into a liquid, highly corrosive electrolyte (1,2), which also serves as a water feedstock. The electrodes are separated by a membrane (3) that is porous to the charge carriers, OH<sup>-</sup>, but not to oxygen and hydrogen, which are produced separately at the surface of each electrode. The liquid electrolyte must be circulated and regenerated in an additional circuit, increasing balance of plant complexity. Alkaline cells differ fundamentally from PEMs and SOECs, which consist of fixed elements only.

Note: The annual increase in cell potential is inversely proportional to its efficiency.

Source: NEL Hydrogen (2011); 2. A.T. Kearney Energy Transition Institute review, based on PlanSOEC (2011); EIFER (2011) and manufacturer websites;

3. Cell schematic: Fraunhofer (2012); 4. Image courtesy of: IHT, Electrolyzer type S-556.

## Advantages

- Commercial technology
- Cheapest electrolysis option at the moment (no expensive metals)
- Large stack size
- Ultra-pure hydrogen output

## Drawbacks

- Limited cost reduction potential due to low current densities
- Limited efficiency gains due to the maturity of the technology
- Complex cell design requires maintenance
- Corrosive electrolyte increases risks of deterioration outside nominal operating conditions
- Low reactivity (ramp-up time) compared with PEM
- Low flexibility (~20% minimal load factor to be maintained)
- Operates at high pressure, requiring advanced engineering
- Stacks under 250 kW operate at too low a voltage for usual AC/DC converters

**Figure 43: Alkaline electrolyzer characteristics<sup>2</sup>**

Maturity	Commercial
Current density	300 - 500 mA/cm <sup>2</sup>
Operating pressure	2-10 bars (most existing models), 60 bars (potentially)
Operating temperature	70-90°C
Flexibility (min. load)	5% (state of the art); 20-40% (1 <sup>st</sup> generation models),
Reactivity	Ramp-up from min load to max.: 10 min. before; 10s for new models Black start: 30 to 60 minutes due to nitrogen purging requirement
H <sub>2</sub> gas purity	>99.999%
System efficiency (HHV)	77% at best today, potentially up to 82% at 300mA/cm <sup>2</sup> in the future
System investment costs	\$850 /kW <sub>ch</sub> (today); \$550 /kW <sub>ch</sub> (projected)
Max stack size	2.7 MW <sub>ch</sub>
Largest plant operating	150 MW (150 stacks of 1 MW)
Lifetime	10-20 years proven at 2-4% annual degradation rate <sup>5</sup>

# Proton exchange membrane is a promising competitor to alkaline, but still needs to be proved to be cost competitive in MW-scale applications

## Status and outlook

PEM electrolyzers have the benefit of over 20 years of fuel-cell electric vehicle research, and are suitable for niche market applications, such as military and space engineering. In the past five years, PEM electrolyzers have greatly improved and regularly exceed US DoE performance targets. They remain more expensive than alkaline electrolyzers, but costs are expected to decrease as a result of a modular approach to manufacture<sup>4</sup>. R&D is focused on increasing the surface of the membrane of each cell in order to increase stack capacity, and reducing the precious metal content of the electrodes in order to lower costs. Efforts on the engineering side are principally directed at improving manufacturing processes. First 1 MW-scale PEM stacks are now operational, and will be 30 times smaller and much more flexible than their alkaline counterpart. Siemens is aiming to bring two MW-scale PEM plants into commercial operation in 2015 for efficient control power with slew rate of 30 MW/s, and black start in under ten minutes.

**Figure 44: PEM cell schematic<sup>1</sup> (left) and real 1 kW PEM stack<sup>2</sup> (right)**



- PEM cells (figure 44) do not require any moving parts. The two electrodes are built around a fixed polymer membrane that serves as the electrolyte. Water molecules in contact with the anode are split into oxygen and protons ( $H^+$ ) small enough to pass through the membrane. These recombine as  $H_2$  gas at the cathode. Hundreds of PEM cells are assembled in series to form a stack.

## Advantages

- Design simplicity & reliability (no moving parts, light, compact, modular)
- Compact system
- Similar efficiency to alkaline but at higher current densities
- Very fast response time
- High operating pressure
- Cost reduction potential (modular nature)

## Drawbacks

- High investment costs (noble metals for electrodes, membrane)
- Difficult to manufacture (batch production)
- Lifetime of membranes
- Stack size limited (membrane dimensionally unstable)
- Lower stack rated power
- Requires much greater water purity

**Figure 45: Proton exchange membrane electrolyzer characteristics<sup>3</sup>**

Maturity	Initial commercial stage
Current density	1,000 - 2,000 mA/cm <sup>2</sup>
Operating pressure	15-30 bars (most existing PEM), 300 bars (potentially)
Operating temperature	60-80°C (today). 130-180°C (High-temperature PEM in the labs)
Flexibility (min. load)	0%
Reactivity	<ul style="list-style-type: none"> <li>• From standby to full load: &lt; 10s (~1 second for best models)</li> <li>• Black start: &lt; 10 minutes</li> </ul>
H <sub>2</sub> gas purity	99.9%
System efficiency (HHV)	77% commercial, potentially up to 84% at 1,000mA/cm <sup>2</sup>
System investment costs	\$1,000-2,000 /kW <sub>ch</sub> (today), \$760 /kW <sub>ch</sub> (expected at mass production)
Max stack size	100 kW <sub>ch</sub> today (500 cm <sup>2</sup> membrane). 1 MW <sub>e</sub> stack under construction by Hydrogenics for the E.ON Hamburg P2G project
Largest plant operating	1 MW <sub>e</sub> made of hundreds of stacks
Lifetime	5 years proven at 2-4% degradation rate, and improving

Note: 4. This modular approach to manufacture could enable a “solar PV-like” learning curve, where economies of scale in the manufacturing of PV cells have roughly resulted in a 20% decrease in costs for each doubling of capacity

Source: Image courtesy of: 2. Hydrogenics; 1. Fraunhofer ISE (2010); 3. A.T. Kearney Energy Transition Institute review, based on PlanSOEC (2011); EIFER (2011) and manufacturer websites.

# The solid oxide electrolyzer cell is a groundbreaking technology at the laboratory stage that could co-electrolyze water & CO<sub>2</sub> to produce syngas for synthetic fuel processing with very high energy efficiency

## Status and outlook

Investigations into solid oxide electrolyzer cell [SOEC] started in the early 2000s, because SOEC was seen to offer two structural advantages over proton exchange membrane [PEM] and alkaline (figure 47) electrolyzers: SOECs operate at high temperatures, allowing very high efficiencies at reasonably high current densities, potentially allowing for low capital costs per kW; and the ability of SOECs to co-electrolyze water & CO<sub>2</sub> (figure 46) could be a shortcut to power-to-synfuel (see Section 2.5). SOECs can also be used in reverse mode (as a fuel cell to produce electricity), minimizing investment costs for hydrogen-based electricity balancing systems. However, this immature technology will only be viable if an increase in electrolyzer lifetime is achieved. As a result, SOECs are more likely to be used in co-electrolysis mode rather than for producing only hydrogen.

Figure 46: SOEC cell schematic and principle

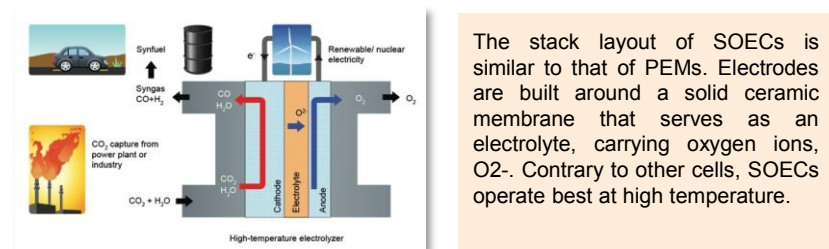

- A significant amount of the energy required can therefore be provided as thermal energy (heat) instead of electricity, improving energy efficiency up to nearly 100%. SOECs can also electrolyze both H<sub>2</sub>O and CO<sub>2</sub> to produce a mix of H<sub>2</sub> and CO called “syngas”, which can be further processed into synthetic fuel. Another advantage is that SOECs can be used both as electrolyzers and as fuel cells, paving the way for efficient and low-cost round-trip electricity storage.

## Advantages

- Highest energy efficiency (~100% at the stack level)
- Low capital costs: high density and no noble metals
- Possibility of co-electrolysis of CO<sub>2</sub> or H<sub>2</sub>O to produce syngas (H<sub>2</sub> + CO)
- Reversible use as a fuel cell with possibility of heat recycling synergies

## Drawbacks

- Immature technology
- Poor lifetime: material stability at high temperatures unproven, especially under high current density or variable load conditions
- Limited flexibility: constant load recommended to achieve better efficiencies and avoid cell breakdown

Figure 47: Solid oxide electrolyzer cell characteristics<sup>1</sup>

Maturity	R&D
Current density	500 - 1,000 mA/cm <sup>2</sup>
Operating pressure	10-40 bars favored for further syngas processing
Operating temperature	700-900°C
Flexibility (min. load)	N/A
Reactivity	N/A
H <sub>2</sub> gas purity	N/A
System efficiency (HHV)	89% (today); 98% (future potential)
System investment costs	\$212 /kW <sub>ch</sub> expected at mass production (500 MW per year)
Max stack size	10 kW <sub>e</sub>
Largest plant operating	18 kW <sub>e</sub>
Lifetime	1 year proven at 17% degradation rate, 1,000h proven with negligible degradation rate. Less than 8% is needed before commercialization

Note: 2. Energy efficiency is defined as hydrogen's higher heating value divided by the total energy input (heat + electricity). The power-to-hydrogen energy efficiency can be higher than 100%.

Source: 1. A.T. Kearney Energy Transition Institute review, based on PlanSOEC (2011), EIFER (2011), DTU (2012b).

# Significant improvements in the electrochemical performance of electrolyzers have been made in the past decade

There has been a renewed interest in electrolyzers in the past decade, motivated by the rapid increase in variable renewable power capacity worldwide:

- **Proton exchange membrane [PEM]:** Thermodynamic performance – efficiency vs. current density (figure 48) – has greatly improved as a result of R&D efforts in PEM fuel cell electric vehicles and now exceeds the US DoE's 2017 targets. In addition, stack capacities and operating pressures have increased tenfold in the past decade: the first 1 MW PEM stack should be operational in 2013<sup>4</sup> and lab tests above 300 bar have yielded encouraging results. R&D remains focused on materials used for the cell membrane, collector and separators (figure 50).
- **Alkaline:** The electrochemical performance of commercial alkaline technology is limited (figure 48). Nevertheless, state-of-the-art commercial models have successfully improved reactivity and flexibility, with proven minimal loads of 5% to 10% and ramping rates of under 10 seconds. Thermodynamic improvements are expected at higher operating temperatures (up to 200°C) and pressures: current densities of 2.3 A/cm<sup>2</sup>, achieving efficiency of up to 84.5%, have been reached at 250°C and 40 bar. New cells designs are required to inhibit degradation at higher temperatures (figure 49).
- **Solid oxide electrolyzer cells [SOEC]:** These high-temperature (800°C) electrolyzers achieve the highest possible electrochemical performance. Energy conversion efficiency approaches 100% at the stack level and 90% at the system level for current densities as high as 1A/cm<sup>2</sup>. The specific power-to-hydrogen efficiency can exceed 100% at the system level, provided the necessary heat is not generated from electricity. R&D is focused on improving SOEC cell lifetime. So far, only one year of operation has been completed, achieving a 17% degradation rate. Negligible degradation rates have been observed for 1,000 hours of operation<sup>2</sup>. A degradation rate of less than 8% over a period of 20,000 hours must be achieved before commercialization is possible.

**Figure 48: Electrochemical performance<sup>1</sup> of electrolyzer systems**

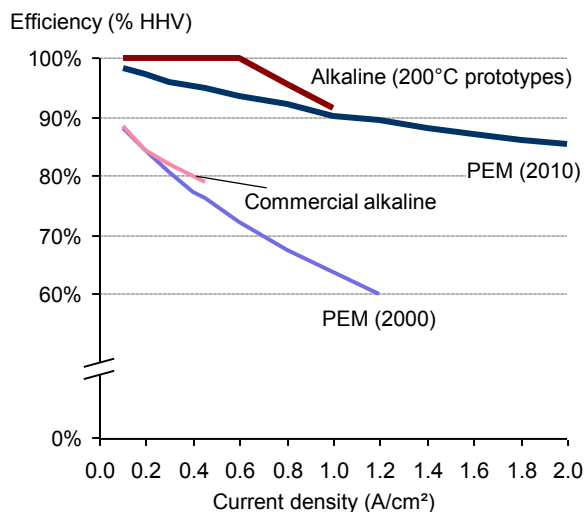

**Figure 49: Alkaline cell design R&D<sup>2</sup>**

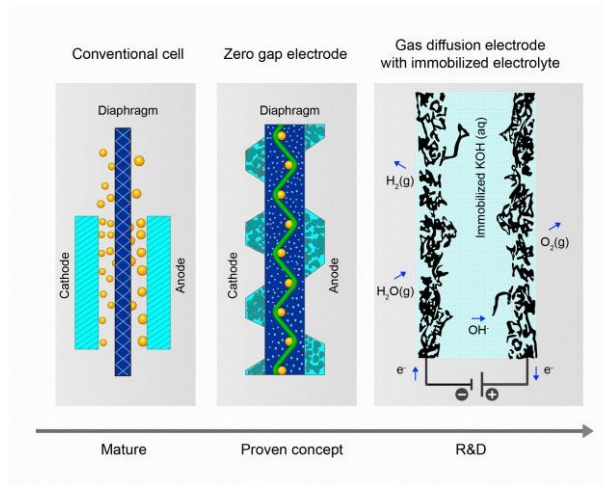

**Figure 50: PEM cell design R&D<sup>3</sup>**

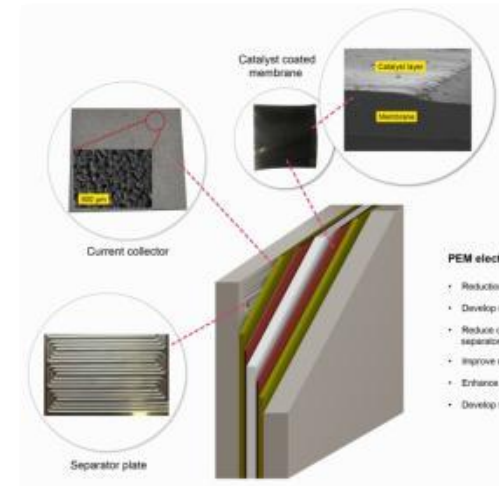

1. Commercial alkaline refers to mature models only.

Source: PEM 2010 performances are based on Hydrogenics (2012); 2. DTU (2012); 3. Carmo et al. (2013); 4. Hydrogenics' 1-MW PEM stack for E.ON Hamburg-Reitbrook pilot project in Germany.

# The priority is to continue to lower investment costs per capacity installed

- **Electrolyzers are entering a phase of development in which engineering and manufacturing will become the prevalent issues, rather than efficiency:** unlike early industrial electrolyzers, which used baseload hydroelectricity, modern electrolyzers use surplus electricity from low-cost renewables, which implies a relatively limited number of operating hours per year. **When utilization rates are low, investment costs become a greater consideration than efficiency.** Two main levers exist for reducing the capital costs of electrolyzers: (i) Reduce manufacturing costs per cell area and (ii) Increase current density.
- **The priority in the case of proton exchange membrane [PEM] technology** is reducing manufacturing costs per cell area: despite large reductions in the past decade, commercial PEMs still have higher capital costs than their alkaline counterparts (figure 51). Whether PEMs will be able to rival alkaline depends chiefly on their cost-reduction potential. Levers for cost reduction include: (1) Cell improvements: develop wider and thinner polymer membranes that are equally resistant to degradation; reduce noble metal catalyst loadings for PEMs electrodes. The cell currently accounts for 72% of stack cost and for 38% of total plant cost<sup>3</sup>; (2) Stack improvements: reduce labor costs (33-60% of PEM stack costs) through mass production and new manufacturing techniques; and (3) Plant improvements: achieve economies of scale on the balance of system.
- **The priority for alkaline cells** is increasing current densities (figure 52), which will require the development of more durable materials, capable of resisting higher temperatures. Finally, **SOECs** should have very low capital costs per capacity installed since their membranes do not require costly noble metal catalysts and current density is high. At mass production rate (500 MW/year), SOEC stack costs should fall to \$72/MWh<sub>ch</sub> and an installed plant should cost \$212/MWh<sub>ch</sub><sup>4</sup>.

**Figure 51: Evolution of PEM stack and system costs<sup>1</sup>**

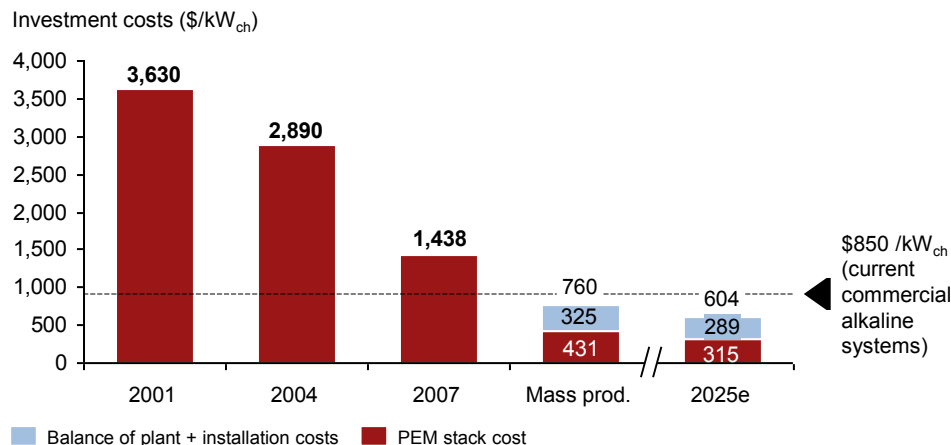

Note: System efficiency is 73% until 2007, 79% in 2011, 85.6% in 2025.

Source: 1. Stack costs are given by Giner (2012); BoP and installation costs were estimated by A.T. Kearney Energy Transition Institute, based on US DoE H2A models; 2. A.T. Kearney Energy Transition Institute analysis;

3. For a 20 kW PEM plant, according to Ayers et al. (2010); 4. Plan SOEC (2011).

**Figure 52: Comparative advantages and drawbacks of electrolyzer types<sup>2</sup>**

Qualitative scale (center: bad – periphery: good)

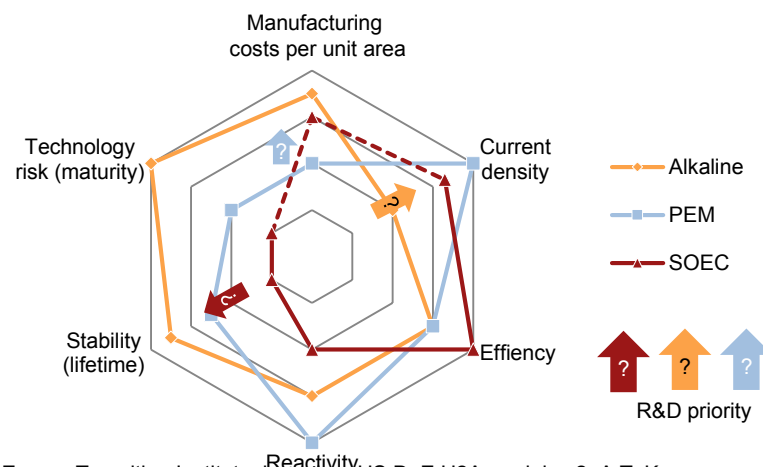

# The levelized cost of hydrogen depends not only on electrolyzer costs and efficiency, but also on the price of electricity, the utilization rate and the project's discount rate

The levelized cost of hydrogen [LCOH] (in  $\$/\text{MWh}_{\text{ch}}$ ) is the real production cost of hydrogen and may be benchmarked against alternative production processes. The LCOH is specific to each project and equals the price at which  $\text{H}_2$  needs to be sold to make the investment in the plant break even. LCOH depends on (figure 53):

- Electrolyzer performance:
  - Investment costs ( $\$/\text{kW}$ );
  - System efficiency profile (%) as a function of its load factor;
  - Maintenance costs (fixed:  $\$/\text{kW}/\text{year}$  or variable:  $\$/\text{kWh}$ ).
- External influences on project:
  - Utilization rate (load-factor profile throughout project lifetime);
  - Discount rate (%), which reflects the producer's cost of capital;
  - Electricity costs (price-duration curve of electricity costs);
  - Potential heat and/or oxygen selling price;
  - Local labor & installation costs.

Figure 53: Levelized cost of hydrogen's impacting factors

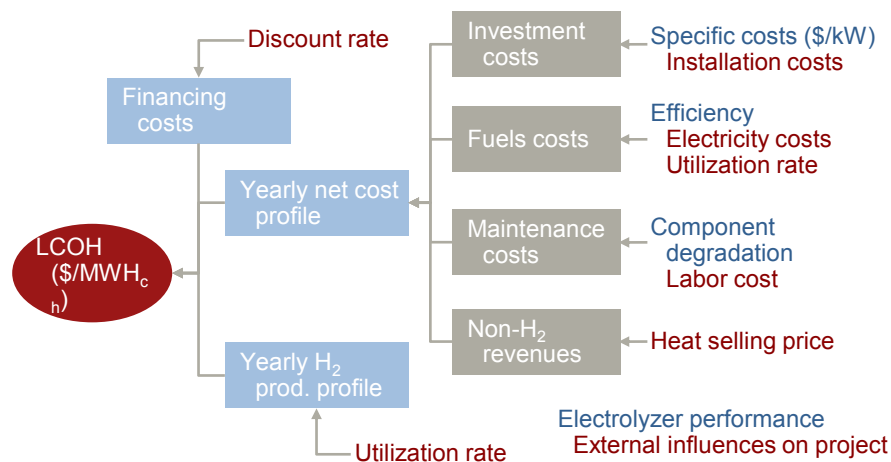

Note: Throughout the report, the levelized cost of output is calculated by A.T. Kearney Energy Transition Institute for a US alkaline electrolyzer plant, with associated O&M costs, plant lifetime of 30 years, real discount rate of 10% and prices in 2010 dollars. Assumptions on plant size, capital costs and efficiency are indicated in the notes; here: 85 MW plant size, capital cost  $\$733/\text{kW}_{\text{ch}}$  and system efficiency 79%.

Source: A.T. Kearney Energy Transition Institute analysis, based on US DoE H2A production models.

- The effects of the electricity price and capital investment on the LCOH vary according to the utilization rate (or annual load factor) of the electrolyzer plant (figure 54).
- When using the electrolyzer for baseload power or for peak shaving (nearly 100% load factor), electricity prices constitute the large majority of the LCOH. In this case, efficiency plays a decisive role in determining the share of LCOH for which the electricity price is responsible.
- If the electrolyzer is only utilized less than 20% of the time (for instance, for monetizing temporary excesses of electricity production), investment costs become the most critical component of LCOH.
- For utilization rates between 20% and 90% – such as in price arbitrage strategies based on variations in the market price of electricity – both capital costs and efficiency have an impact on project economics.

Figure 54: LCOH breakdown of an electrolyzer plant as a function of its annual load factor, for a fixed electricity price of  $\$65/\text{MWh}_e^1$

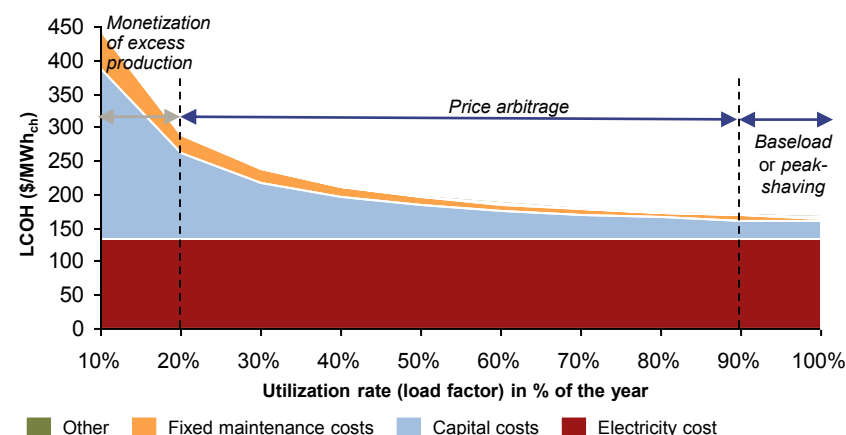

## Operated in baseload mode, electrolyzers incur higher levelized production costs than steam methane reforming

- **Assuming a plant load factor of 100% and invariable electrolyzer performance, the levelized cost of hydrogen (LCOH) is linearly dependent on the average electricity price.** State-of-the-art and future electrolyzer plants of various sizes have been benchmarked against each other and against steam methane reforming [SMR] plants – the most common hydrogen-production method (figure 55). The analysis does not take into account the compression, storage or delivery costs of hydrogen, nor environmental externalities such as the cost of carbon. Key findings are:
- **Electrolysis is generally more expensive than SMR**, except when average electricity prices remain very low throughout the year. The graph indicates the relative competitiveness of electrolysis/SMR according to electricity prices. Unless electricity prices are high, electrolysis is more profitable than SMR when H<sub>2</sub> production is decentralized in regions with high natural gas costs.
- **Electrolyzer LCOH is not significantly affected by plant size – the principal advantage of electrolysis over SMR.** Under prevailing market conditions and operated in baseload mode, decentralized production costs roughly 5% more than centralized production, whereas SMR production costs are twice as high when it is decentralized. The H<sub>2</sub> transport costs avoided by decentralized production amount to approximately \$30-60 /MWh<sub>ch</sub>, depending on plant configuration.
- **By 2025, improved electrolyzer performance should reduce LCOH in baseload mode by up to 10%.** SMR technologies are also expected to improve, with energy efficiency increasing from 69% to 83% by 2015. Feedstock costs (natural gas, electricity) remain uncertain.

**Figure 55: Range of LCOH for an electrolyzer utilized at full load, without compression, storage or delivery, as a function of feedstock electricity price**

LCOH (\$/MWh<sub>ch</sub>)

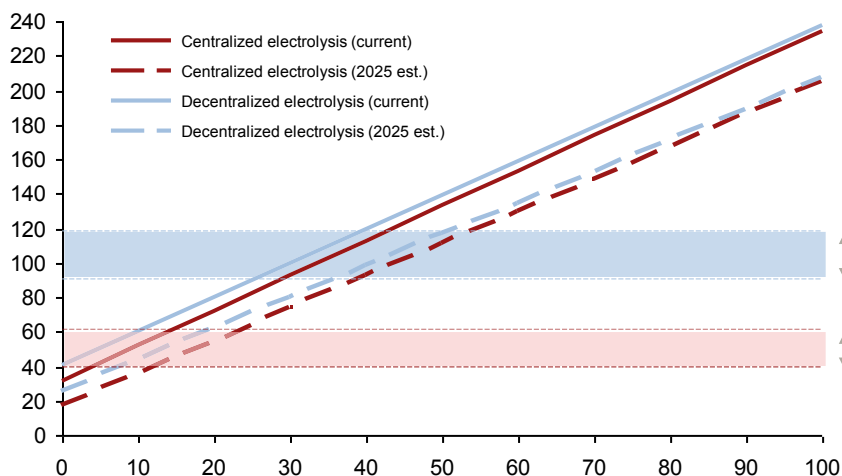

**Assumptions for electrolyzer performance\***

	Centralized (85MW <sub>ch</sub> , 1bar)	Decentralized (2.5MW <sub>ch</sub> , 1 bar)
<b>Current</b>	\$733 /kW <sub>ch</sub> capital costs 78% efficiency	\$850 /kW <sub>ch</sub> capital costs 78% efficiency
<b>2025 estimates</b>	\$450 /kW <sub>ch</sub> capital costs 85.8% efficiency	\$560 /kW <sub>ch</sub> capital costs 85.8% efficiency

\*Throughout this report, electrolyzer CAPEX will be estimated by a linear extrapolation based on the plant size, between the centralized and decentralized values of reference

Decentralized SMR at natural gas price range \$14-35 /MWh<sub>ch</sub>

Centralized SMR at natural gas prices range \$14-35 /MWh<sub>ch</sub>

Average electricity price (\$/MWh<sub>e</sub>)

## A lower levelized cost of hydrogen can be achieved with a price arbitrage strategy on feedstock electricity by lowering the annual load factor of the plant – illustrative

- **Grid-connected electrolyzers can buy electricity from the spot market, where it is traded hourly (see Box 9: electricity market). Prices can vary greatly throughout the year** (grey line, figure 56). Hourly prices over one year are summarized by a price duration curve, which ranks them by ascending price order (dark blue line, figure 56): The curve indicates that hourly prices are lower than their annual average ( $\$77/\text{MWh}_e$ ) for more than half of the year. **This creates opportunities for price arbitrage** (lowering the annual load factor of the plant so that it operates primarily during periods of low-cost electricity). In theory, the best deal for the project owner would be to buy electricity in ascending price order, in which case its average electricity feedstock costs (light blue curve) would always be lower than the annual spot mean. In practice, the electrolyzer is set to operate only when spot prices are below a set threshold: since the price duration curve is not known before the end of the year, a price-arbitrage strategy does not allow precise control over the annual load factor of the plant.
- **If price arbitrage could be realized perfectly, the levelized cost of hydrogen [LCOH] would be reduced as shown in the graph:** the difference between the blue line and the dashed red line in figure 57. Of course, price arbitrage serves no purpose if the plant is operated in baseload mode. At the same time, operating the plant too little throughout the year leads to an unaffordable LCOH because the capital invested is not being used. Therefore, it is necessary to determine the **optimal plant load factor – one that minimizes the LCOH while preserving price-arbitrage opportunities on the purchase of electricity**. The lowest LCOH is achieved when the electrolyzer is operated with a load factor of 55%. This lowers LCOH by 12% compared with a 100% load factor.
- Finally, two alternative electrolyzer plants have been compared with the reference plant (the yellow and green curves) (figure 57). **High efficiencies are useful for high load factors, while low capital costs are essential for highly discontinuous operations**. Because there is usually a trade-off between electrolyzer costs and their efficiencies, the choice of electrolyzer depends on the utilization rate planned for the plant.

Figure 56: Illustrative electricity spot market price over one year<sup>1</sup>

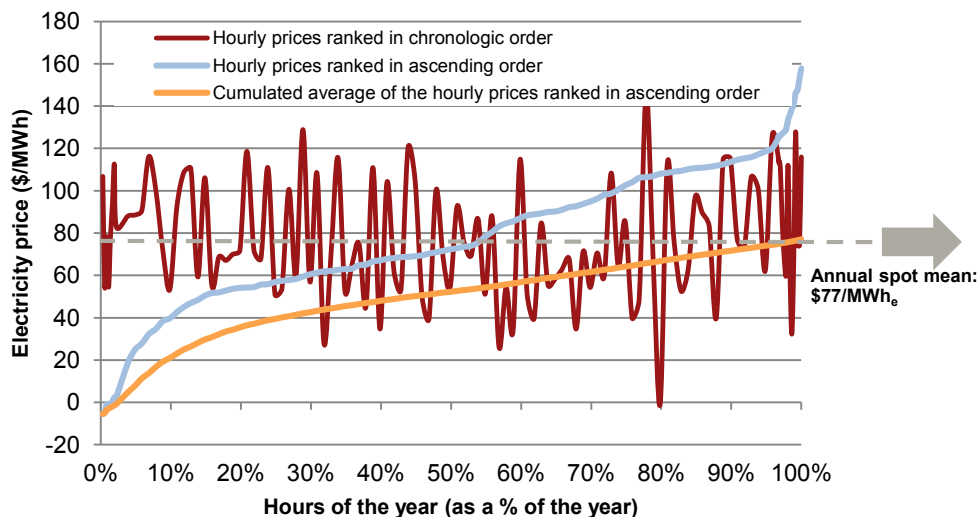
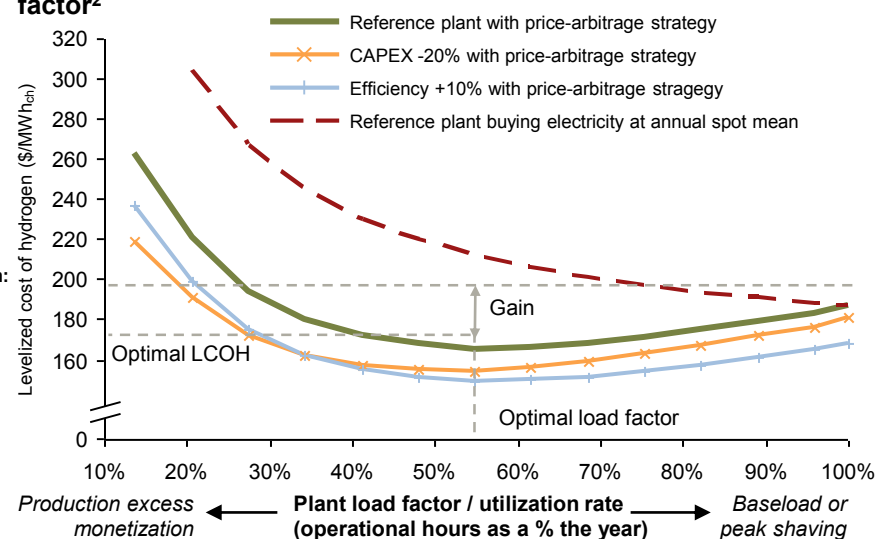

Figure 57: Resulting LCOH as a function of the annual load factor<sup>2</sup>



1. These illustrative prices have been created by stretching hourly Nord Pool 2011 spot price variations around their average by a factor of 2 and adding a fixed  $\text{€}30/\text{MWh}$ ; 2. A.T. Kearney Energy Transition Institute analysis, based on US DoE H2A production models, for an alkaline plant with total installed system CAPEX:  $\$765/\text{MWhch}$  and 78% efficiency based energy 61

## At present, electricity price spreads on the spot markets are too narrow to enable significant hydrogen-production cost reductions through price arbitrage – German and French case study

The previous slide illustrated the qualitative impact of electricity price spreads and electrolyzer performance on the levelized cost of hydrogen [LCOH]. Here, we use real, hourly data from the French and German 2012<sup>1</sup> spot market (figure 58). The French and German spot markets have very similar price duration curves because they are closely interconnected. As a result, the number of hours per year with negative prices is also very similar (36h in France, 56h in Germany) and the cumulated average price duration curve remain below zero for load no more than 3% of the year.

Yet, 3% utilization is far from sufficient to operate a plant economically (figure 59). **Spot-price arbitrage leads to an optimal utilization rate of 80%, which would involve the plant being operated in peak shaving mode. As a result, LCOH would be reduced by only 4% compared with baseload mode.** Therefore, not only are spot-price duration curves in Germany (and France) currently too “flat” to enable the use of grid-connected electrolyzers solely for monetizing excess electricity supply, they do not even give rise to significant hydrogen production-cost reductions.

Nevertheless, LCOH could be further reduced, provided<sup>3</sup>:

- **The spot-price spread increases:** the potential positive correlation between intermittent renewable penetration and price spread is discussed in Section 3.2, cases No. 1
- **Electrolysis can contribute to short-term grid stability:** (figure 59) it shows that the plant could be operated as infrequently as 50% of the time without raising the LCOH above its baseload-mode level. Idle time could be used for involvement in the balancing or capacity markets. Section 3.2, case No. 1 shows the benefits of optimizing electricity sales on the balancing and the spot market simultaneously.
- **Electrolyzers can be improved:** Currently, high capital costs prevent electrolyzers from operating with low load factors. In future, it will be essential to reduce investment costs per unit of installed capacity in order to capitalize on short periods of low electricity prices, and allow discontinuous operation. Efficiency has little impact on gains from price arbitrage.

**Figure 58: Electricity spot price duration curves (France & Germany, 2012)<sup>1</sup>**

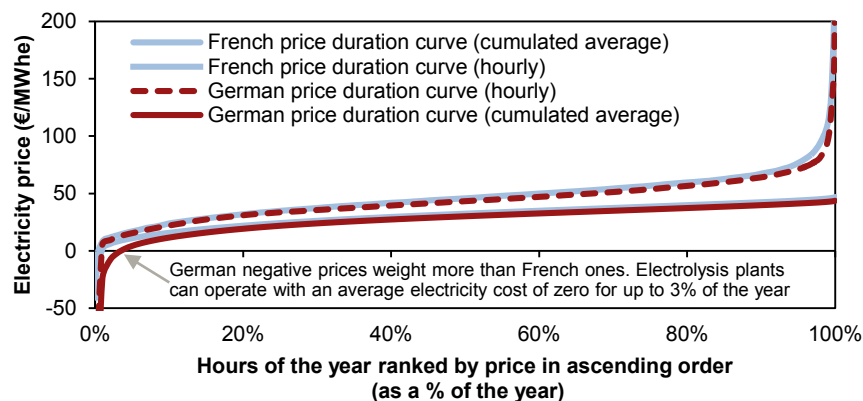

**Figure 59: LCOH of a grid-connected electrolysis plant (Germany, 2012)<sup>2</sup>**

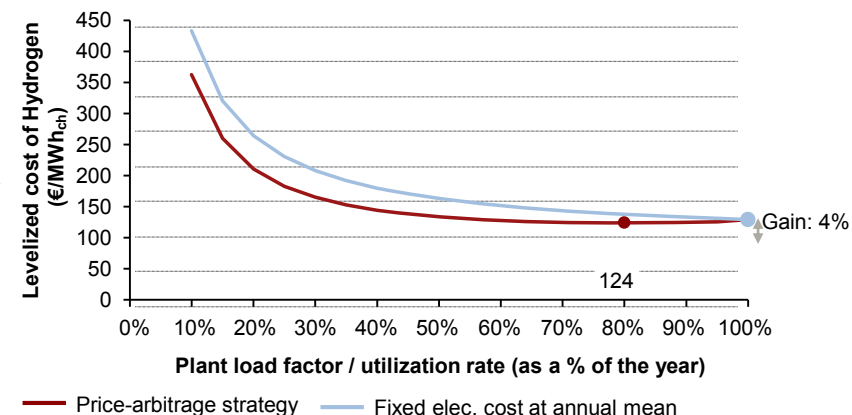

1. EPEX SPOT intraday trading “index price” for each hour of 2012. Intraday SPOT and day-ahead SPOT auctions have been found to give very similar price-duration curves; 3.

Other indirect LCOH reduction levers exist: e.g. sales of oxygen or heat co-produced in electrolysis, improved project financing conditions.

Source: 2. A.T. Kearney Energy Transition Institute analysis, based on US DoE H2A production models, for a 10 MW alkaline plant with total installed system CAPEX of \$848 /MWh<sub>ch</sub> and 78% efficiency.

## Sources: section 2.1

- Ayers et al. (2010), “*Research advances towards low cost, high efficiency PEM electrolysis*”, Kathy Ayers, Everett Anderson, Christopher Capuano
- Carmo et al. (2013), “*A comprehensive review on PEM water electrolysis*”, Marcelo Carmo, David L. Fritz, Jürgen Mergel, Detlef Stolten, International Journal of Hydrogen Energy, vol. 38, pp. 4901-4934
- European Power Exchange – EPEX (2012), Spot Intraday Trading index price dataset
- European Institute for Energy Research – EIFER (2011), “Role of electrolysis and regenerative syngas and synfuel production”, Qingxi Fu
- Fraunhofer Institute for Solar Energy Systems – ISE (2010), “PEM water electrolysis – present status of research and development”; Tom Smolinka
- Fraunhofer Institute (2012), “*NOW-Studie-Wasserelektrolyse*”
- FuelCellToday (2013), “*Water electrolysis & Renewable Energy Systems*”
- Giner (2012), “*PEM Electrolyzer Incorporating an Advanced Low Cost Membrane*”
- Graves et al. (2010), “*Sustainable hydrocarbon fuels by recycling CO<sub>2</sub> and H<sub>2</sub>O with renewable nuclear energy*”, Christopher Graves, Sune D. Ebbesen, Mogens Mogensen, Klaus S. Lackner, Renewable and Sustainable Energy Reviews 15, pp. 1-23
- Hydrogenics (2012), “*Electrolysis for grid balancing - Where are we?*”
- Lemus et al. (2009), “*Updated hydrogen production costs and parities for conventional and renewable technologies*”; Ricardo Guerrero Lemus, Jose Manuel, Martinez-Durant, International Journal of Hydrogen Energy 35, pp. 3929–3936
- NEL Hydrogen (2011), “*If the future could choose*”, Brochure, [http://www.nel-hydrogen.com/home/docs/If\\_The\\_Future\\_Could\\_Choose\\_2.pdf](http://www.nel-hydrogen.com/home/docs/If_The_Future_Could_Choose_2.pdf)
- National Renewable Energy Laboratory – NREL(2009), “*Hydrogen Pathways Technical Report*”
- Nordpool (2011), Elspot prices dataset, <http://www.nordpoolspot.com/>
- Plan SOEC (2011), “*R&D and commercialization roadmap for SOEC electrolysis R&D of SOEC stacks with improved durability*”
- SRI (2007), “*Industrial gases by the chemical economic handbook*”
- Technical University of Denmark – DTU (2012a), “*High Temperature and Pressure Alkaline Electrolysis Cell*”, Frank Allebrod, Christodoulos Chatzichristodoulou, Mogens Mogensen, Processing of the World Hydrogen Energy Conference 2012
- Technical University of Denmark – DTU (2012b), “*Solid Oxide Electrolysis Hydrogen production*”, Peter Vang Hendriksen, Fuel Cells and Solid State Chemistry Division
- United States Department of Energy – US DoE, The Hydrogen Analysis (H2A) Project, Hydrogen and Fuel Cell Program, [http://www.hydrogen.energy.gov/h2a\\_analysis.html#h2a\\_project](http://www.hydrogen.energy.gov/h2a_analysis.html#h2a_project)

## 2.2 - Hydrogen storage & transport



## Summary & key findings: section 2.2

1. **Hydrogen storage and transport form the most mature segment of the chain, benefiting from the chemicals and petrochemicals industries' extensive experience of hydrogen utilization.** Storage is mainly in gaseous form (pressurized tanks, underground reservoirs), liquid form (cryogenic tanks) or in metal hydrides. Hydrogen is mainly transported by pipeline (gaseous) or road (in gaseous or liquefied form, held in tanks). These technologies are technically mature, other than metal hydrides and all underground reservoirs except man-made salt caverns (aquifers and depleted oil & gas reservoir). **Hydrogen needs to be conditioned (compressed, liquefied or absorbed) prior to handling** because it is too diffusive in ambient conditions, incurring energy losses of 5-15% for compression and 25-45% for liquefaction. The choice of conditioning constrains the type of transport and storage solutions that can be used.
2. **The challenge is, first and foremost, economic, as H<sub>2</sub> is a volatile chemical that is relatively expensive to handle.** The levelized cost of H<sub>2</sub> storage & transport largely depends on project configuration (size, distance and type of storage & transport system)..
3. **The choice of storage type depends largely on the energy capacity requirement and space constraints, but also on the desired operating cycling rate:**
  - Pressurized tanks are preferred for storage systems subject to high cycling rates (at least one charge or discharge per day), because the capital cost per unit of energy capacity (\$/kWh) of the tank is high and needs to be amortized by frequent utilization. This solution is economically up-scalable (by adding more tanks), as long as the cycling rate is high. Hydrogen leakage is negligible when stored in gaseous form or in hydrides;
  - Underground storage (mostly in man-made salt caverns) allows lower cycling rates (weekly or monthly), because the capital cost per unit of energy capacity is much lower. This is by far the most competitive and energy-efficient option for large-scale storage, but is likely to suffer from limited geological availability. Furthermore, fixed construction costs (e.g. well drilling costs) prevent underground storage from being built for small energy-storage capacities;
  - Metal hydrides might be a useful way of storing tens of MWh for systems with cycling rates between a day to a week, but they must still demonstrate their techno-economic feasibility. Their main advantage is a minimal energy penalty and great handling safety; and
  - Liquid storage is mainly suitable for large-scale, centralized storage associated with long distance transport to distributed end-users.
4. **The choice of hydrogen-transportation method depends largely on the transport distance and hydrogen throughput** (energy delivered per day). Hydrogen transportation, in itself, incurs limited energy losses in addition to those incurred by conditioning:
  - Road transport enables distributed delivery. Transport of compressed hydrogen in tanks is limited to short distances and low throughputs. Liquid H<sub>2</sub> transportation may only be viable for large quantities delivered over long distances to numerous locations, most likely refueling stations; and
  - Pipelines can provide a low-cost option for point-to-point delivery of large volumes of hydrogen. However, they lack the flexibility of road vehicles for distributed delivery. Furthermore, pipe-laying incurs significant up-front costs, which, in view of current demand for H<sub>2</sub>, will inhibit the expansion of hydrogen pipelines.
5. **Overall, transport & storage are costly steps that could be partially avoided by decentralized hydrogen production.**

## Hydrogen storage and transport is the most mature segment of the hydrogen industry, given the chemicals and petrochemicals industry's experience of handling hydrogen

**Technologies used to store and transport hydrogen are mature.** Although hydrogen is not yet used as an energy-storage medium, it has long been a valuable commodity, used – in particular – by the petrochemicals, refining and fertilizer-production industries. Although hydrogen is mostly produced where it is consumed (captive production), storage and, to some extent, transport are still required (figure 60).

**The main challenge of storing and transporting hydrogen is economic.** It consists of optimizing the cost equation within the constraints of the end-use application, namely the amount of energy to be stored, the storage space availability, the storage duration, the rate of charge and discharge, the transport distance and infrastructure in place, and the safety regulations.

**When produced from variable, renewable-energy-fed electrolysis, hydrogen output is uncertain.** This is especially challenging for storage, as it gives rise to trade-offs between the utilization rate of the facility (linked to the amortization of the initial investment) and the ability to store hydrogen whenever it is produced (*i.e.* derived from variable renewable patterns) – requiring highly responsive storage capacity.

**Figure 60: Hydrogen storage and transport act as buffers between production and end-uses**

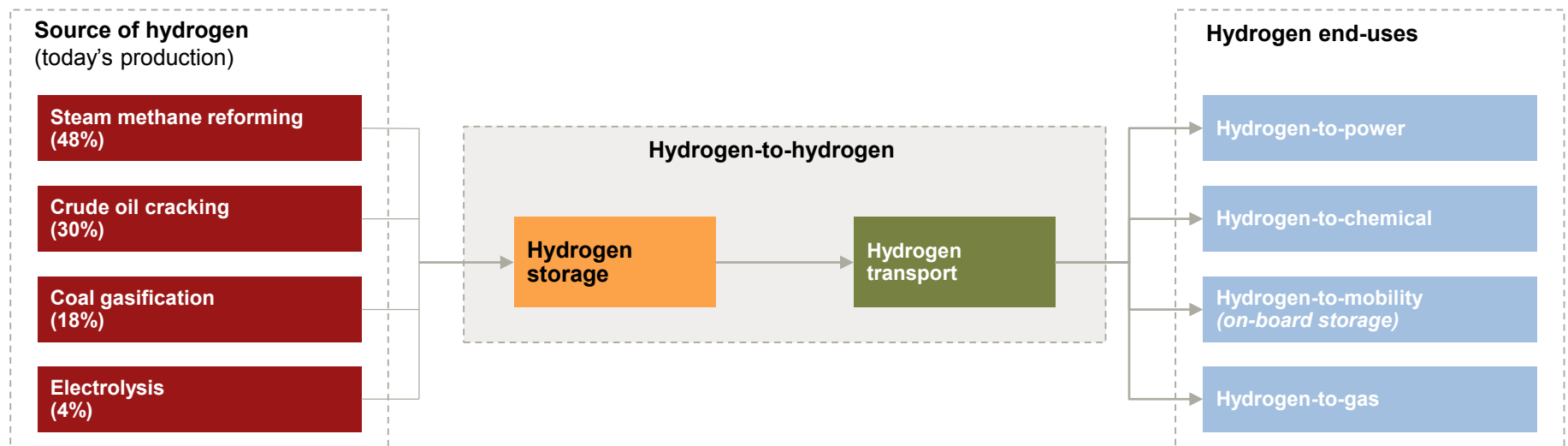

# Hydrogen conditioning is a pre-requisite for storage and transport

**The use of hydrogen to store electricity is attractive because of its chemical nature, which makes it easier to store than electricity.** A total of 91% of the world's primary energy supply is in chemical form (coal, gas, oil, biomass), the remaining being nuclear and non-chemical renewables (e.g. hydro, wind, solar).

However, although hydrogen's energy density per mass is very high, due to its extremely light molecules, and is an intrinsic parameter of the molecule, its energy density per volume depends on its conditioning and is very low at ambient conditions (see Box 3 Hydrogen Basics). **As a consequence, the volume of hydrogen gas must be reduced in some way so that it can be practically stored and transported.** This can be through compression, liquefaction (cooling to  $-253^{\circ}\text{C}$ ), or absorption into metal hydrides.

**Storage and transport modes are dictated by the process chosen to densify hydrogen (figure 61).** Compressed hydrogen gas is stored in underground caverns or pressurized tanks, and then transported by pipeline. At a small scale or where short distances are involved, it is stored in pressurized steel cylinders on tube trailers, trains or ships. Liquefied hydrogen is stored in cryogenic tanks that can be transported by any means. Finally, hydrogen absorbed in metal hydrides is stored and transported in solid metal containers.

**Figure 61: Hydrogen 'packaging' between production and end-use: conditioning, storage and transport options**

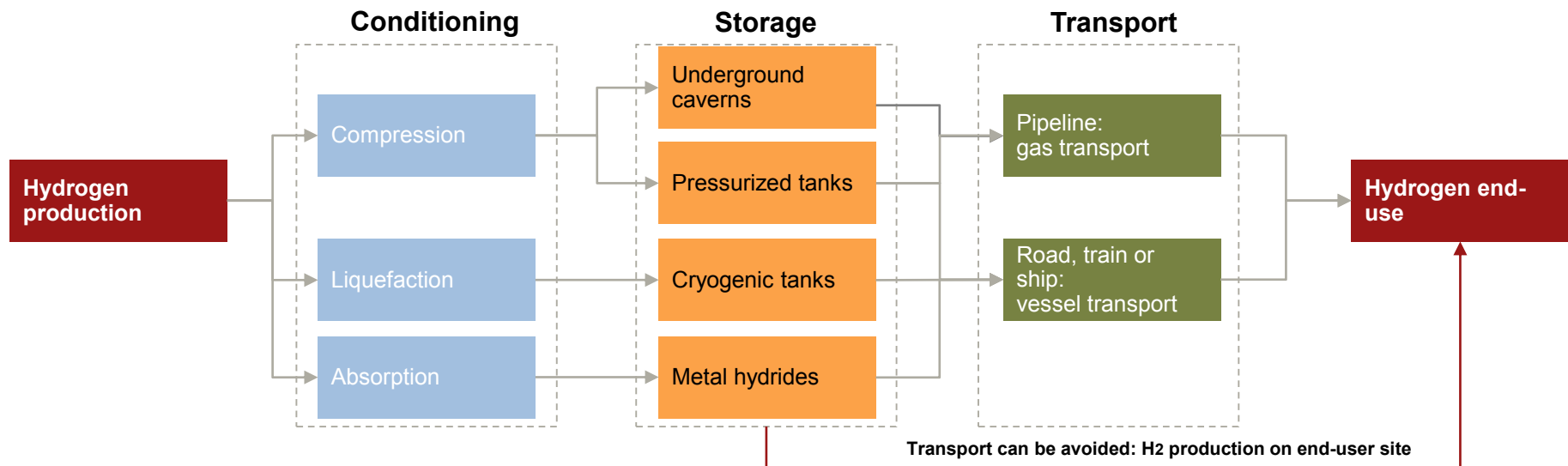

## The choice of storage method depends largely on energy capacity, cycling rate and space constraints

The selection of the most appropriate means of storage is constrained by the requirements of a particular application (figure 62). As usual, the main technology indicators to be monitored are (i) power ratings (instantaneous ability to charge and discharge in MW), (ii) energy capacity (energy that can be stored in MWh), (iii) energy densities (kWh per mass and per volume), and (iv) safety. Storage usually includes a conditioning stage (compression, liquefaction...), which varies according to the transportation options and requirements (e.g. distance, availability of a pipeline...).

Once potential storage sites have been identified, the cheapest option is usually chosen. Costs include the capital invested in the processing facility and the storage vessel, but also operation and maintenance expenses. The latter are mainly influenced by the energy required for processing hydrogen, making the cycling rate (the frequency with which the system is charged/discharged) a significant determinant of cost optimization:

- **Pressurized tanks** are scalable to energy content, can handle a high cycling rate with satisfactory responsiveness and do not suffer from self-discharge, allowing for long-term storage. Depending on storage pressure, density can be relatively poor. The main hurdle is the cost of compression.
- **Underground storage** is highly efficient and can provide very large storage over long time-frames. Despite these advantages, it is likely to suffer from lack of geological availability, and relatively limited cycling frequency.
- **Liquid storage** has the advantage of containing hydrogen with a high energy density. However, cooling and maintaining hydrogen cryogenically incurs significant energy penalties, and storage time is limited, due to a 0.1-0.5% self-discharge per day. Investment in liquefaction facilities is also very costly.
- **Metal hydrides** aim to avoid energy losses incurred during compression or liquefaction. They achieve a very high volumetric density and avoid safety concerns, as the hydrogen is combined with the hydride at ambient pressure. This form of storage is promising, although it remains in the demonstration phase. The kinetics of absorption and the efficiency of the process (notably regarding heat) are yet to be demonstrated on a large scale, though it is already known that metal hydrides will not compete on the same scale as underground caverns.

Figure 62: Comparative table of hydrogen storage technical characteristics

	Maximum cycling rate <sup>1</sup>	Energy storage capacity	Capability for long duration storage <sup>2</sup>	Efficiency	Safety / public acceptance	Volumetric density (system)	Gravimetric density (system) <sup>3</sup>
<b>Pressurized gas tanks (200 – 700 bar)</b>	High – minutes to charge and discharge	0.1– 10 MWh per tank	High – no leakage	89 – 91% (350 bar) 85 – 88% (700 bar) (including compression)	Risk of high pressure explosion.	670–1,300 kWh <sub>ch</sub> /m <sup>3</sup>	3 – 4.8% wt. H <sub>2</sub>
<b>Underground storage</b>	Low – injection and withdrawal limited to 10% of capacity per day	1 GWh to several TWh per cavern	High – insignificant leakage	90 – 95% (including compression)	Social resistance – not in my backyard (NIMBY)	65 kWh <sub>ch</sub> /m <sup>3</sup> at 20 bar	N/A
<b>Liquid storage</b>	Medium – hours to charge and discharge	0.1– 100 GWh per tank	Low – 0.1-0.5% self-discharge per day	55 – 75% (including liquefaction)	Additional fire and explosion hazards	1,400 –1,600 kWh <sub>ch</sub> /m <sup>3</sup>	6.5 – 14% wt. H <sub>2</sub>
<b>Metal hydrides</b>	Medium – hours to charge and discharge	0.1 kWh – 25 MWh (in a standard container)	High – no leakage	80 - 98% <sup>4</sup> (including auxiliary systems)	No significant safety issues	4,200 kWh <sub>ch</sub> /m <sup>3</sup> for MgH <sub>2</sub> hydrides	2 – 7% wt.

1. The speed with which the reservoir can be emptied and refilled; 2. the ability to contain hydrogen for long periods without significant losses; 3. The gravimetric density is measured in % per weight of hydrogen in the system; 4. the efficiency of metal hydrides depends on whether the waste heat is recycled or not.

Source: Cerri et al (2012); US DoE H2A delivery model; Hawkins (2006); McPhy Presentation; Roads2HyCom.

## Hydrogen is likely to be stored predominantly in gaseous form, although metal hydrides may play a growing role

**Energy storage processes are compared by their levelized cost of storage (in \$/MWh) (figure 63).** This is the real cost of charging, storing and discharging hydrogen, and is additional to the purchase cost of hydrogen. It is influenced by the operational cycling rate of the system. Here and throughout the section, cycles are assumed to be repeated without idle time: as soon as it is charged, the system is discharged, and vice-versa, reflecting minimum achievable levelized costs. The energy-storage capacity (in MWh) of each system has been sized so that each cycle fully charges/discharges the reservoir.

**For stationary applications, hydrogen is likely to be used mostly in its gaseous form, so that pressurized tanks will be the main means of storing it in the short term.** They are well suited to small-scale applications, affordable (most of the cost is incurred during compression), safe (years of experience), and efficient, with losses ranging from 9% to 15%, depending on the pressure.

**Underground storage in salt cavern is by far the most competitive option for large energy capacities, as long as the geology allows it.** Less energy is required to compress and inject the hydrogen into a cavern than in any other form of hydrogen storage, and the initial investment per kWh stored is generally amortized by the size of the reservoir.

**Metal hydrides may change the rules of the game for small-to-medium-scale applications in the medium term.** Avoiding hydrogen compression or liquefaction is, in theory, very appealing. Yet the industry remains torn between optimism and caution when it comes to hydride storage. Several players have invested in solid-storage start-ups over the years, but its potential outside niche markets, where its safety and density are crucial advantages (e.g. back-up storage after natural disaster), remains to be proved due to uncertain economics and limited charging/discharging power ratings.

**Liquefied hydrogen is, in many ways, ill-suited to stationary storage applications.** The large investment required for cryogenic facilities and the intensive use of energy use in liquefaction are constraining the technology. However, since, liquefied-hydrogen storage benefits from economies of scale, provides extremely pure hydrogen and avoids the need for compressors in H<sub>2</sub> filling stations, it could play an important role in the long-distance cryogenic transport of large quantities of hydrogen to refueling stations.

**Figure 63: Levelized added cost of hydrogen storage – ranges in literature<sup>1</sup>**  
\$/MWh

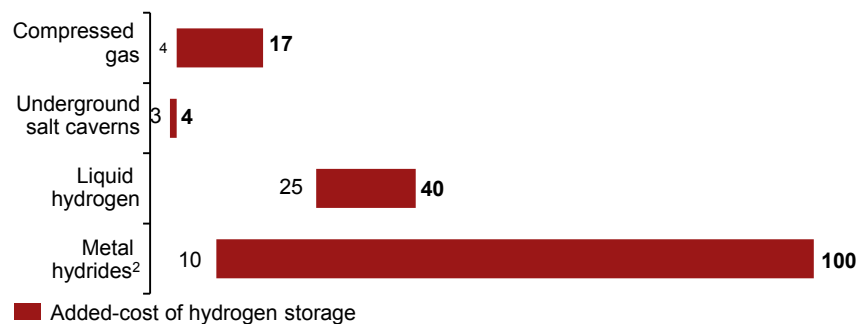

**Figure 64: Energy lost in processing and storage<sup>1</sup>**  
In % of energy input

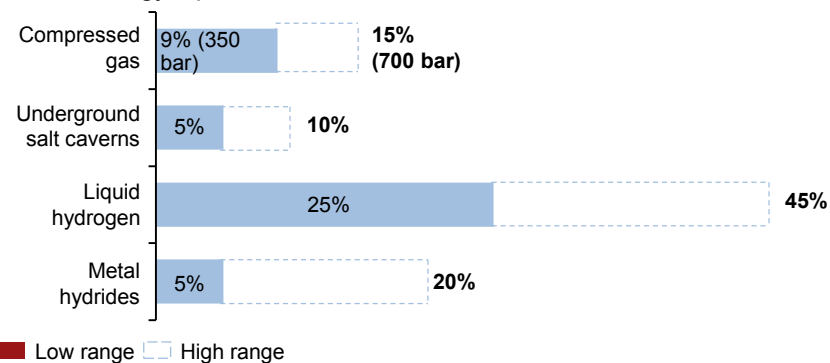

2. The very large range reflects the level of maturity of the technology and, in particular, the uncertainty concerning large-scale manufacture of the hydrides alloy.  
Source: 1. A.T. Kearney Energy Transition Institute analysis, based on Hawkins (2006) and US DoE H2A delivery model.

# The choice between pressurized tanks and underground caverns remains unclear for medium cycling rates

**Pressurized tanks need a high operational cycling rate to be economically feasible.** If the storage time, relative to the power rating, increases beyond a few days, the capital costs of vessels and compressors become a drawback for this technology. Some niche applications may require storage in a few pressurized tanks for longer periods, but they will not be discussed in further detail in this section.

**The geology of underground caverns allows for much longer cycling, because the capital cost of the reservoir per unit of energy is generally negligible for GWh-scale storage.** Those vast caverns are usually large enough to be charged by up to 7% a day, and discharged by 10% a day, which equates to a minimum cycling rate of ~25 days. A shorter cycling rate might be difficult to achieve (several wells would be needed, which could lead to geological instability), or would require smaller caverns whose economic viability remains unproved.

**These constraints leave a potential gap between pressurized tanks and underground storage for cycling rates between days and one week, which could represent an opportunity for metal hydride systems (figure 65).**

Figure 65: Optimal hydrogen storage technology as a function of the desired cycling rate

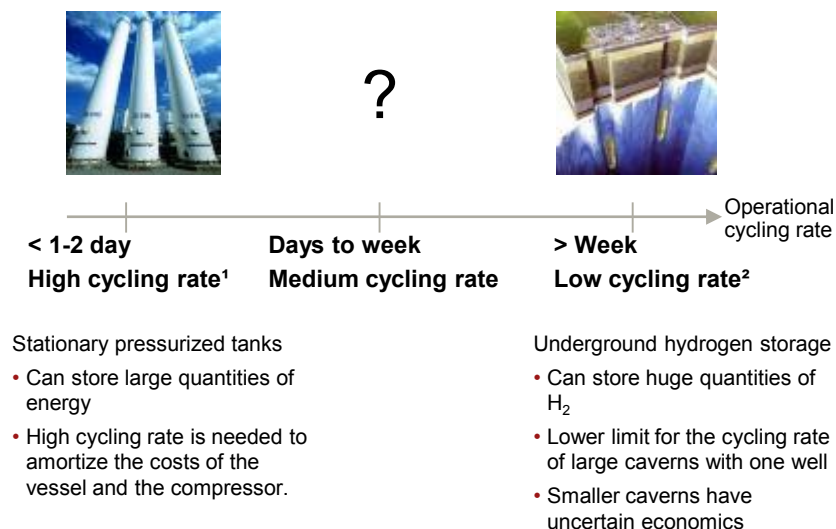
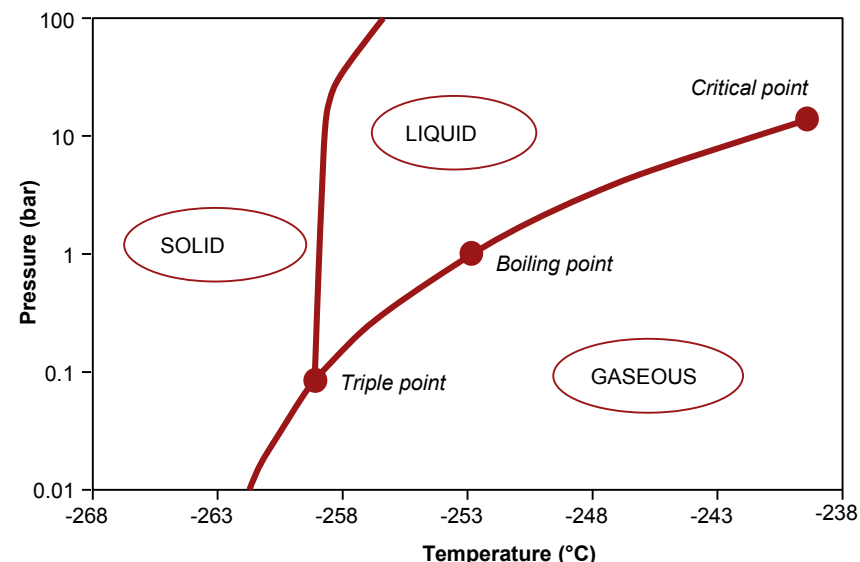

Figure 66: Phase diagram of hydrogen<sup>3</sup>



## Pressurized tanks are the most mature and common hydrogen-storage technology

In order to increase its energy density, hydrogen produced from electrolysis can be compressed and stored in pressurized vessels, mainly tanks, but also bottles. In general, pressurized tanks operate at pressures ranging from 200 to 700 bar.

**The higher the pressure, the higher the cost.** Optimizing storage pressure is therefore essential, and is determined by the volumetric constraints of the storage container. Stationary-tank storage and transport on tube trailers generally require pressures of no more than 200 bar, even though some storage and transport technologies can operate at pressures of up to 1,000 and 500 bar respectively. The end-use application requiring the highest pressure is mobility, usually between 350 and 700 bar.

Pressurized tanks are not subject to self-discharge (*i.e.* leakage) and can therefore accommodate long-term storage. **In practice, their cost is minimized when they are operated with high cycling rates**, *i.e.* a small energy capacity relative to the power rating of the compressor used for charging. Longer storage duration (meaning lower cycling rate) implies that higher capital costs (investment in storage vessels and compressors) need to be amortized while delivering less energy. In other words, **the higher the cycling rate the lower the cost** (figure 67).

**Pressurized vessels are not a major area of interest for R&D in stationary applications, as they are already mature.** However, stationary applications could benefit from R&D being carried out into on-board storage. The focus is on developing new materials and alloys to reduce weight and permit higher pressures without increasing capital costs, and potentially reducing them (all other things – lifetime, efficiency, safety – being equal)..

**Figure 67: Levelized cost of storage according to storage duration, with a fixed rate of production<sup>1</sup>**  
\$/MWh

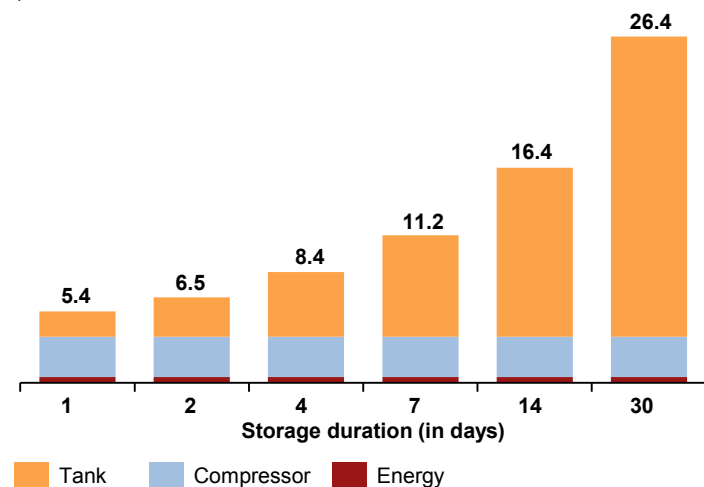

<b>Size</b>	100 kWh – 10 MWh <sub>capacity</sub> per tank
<b>Efficiency (for compression)</b>	89-91% (350 bar); 85-88% (700 bar)
<b>Volumetric density</b>	670-1,300 kWh <sub>ch</sub> /m <sup>3</sup> (17-33 kgH <sub>2</sub> /m <sup>3</sup> )
<b>Gravimetric density</b>	3-4.8wt.% H <sub>2</sub> (system)
<b>Pressure</b>	200-700 bar
<b>Charge/discharge time</b>	Minutes
<b>Capability for long-duration storage</b>	High – no leakage
<b>Investment cost<sup>2</sup></b>	~\$1-3 /MW (compressor) / \$6,000-10,000 /MWh (storage tank)
<b>Advantages over other hydrogen storage methods</b>	<ul style="list-style-type: none"> <li>• Mature</li> <li>• Fast charge/recharge time</li> <li>• Easy to transport</li> </ul>
<b>Drawbacks relative to other hydrogen storage methods</b>	<ul style="list-style-type: none"> <li>• Low volumetric and gravimetric density, resulting in large and heavy tanks</li> <li>• Low storage capacity per vessel;</li> </ul>

1. Based on Hawkins (2006), with kg/day of H<sub>2</sub> converted to MWh/day and a fixed rate of production of 17.8 MWhch hydrogen; 2. \$1/ MW is the base case for a 4 MW compressor, with a scaling factor of around 0.8. Compressor cost is high due to the need to keep H<sub>2</sub> free of contamination from oils or water and to low manufacturing volumes.  
Source: A.T. Kearney Energy Transition Institute analysis, based on 1Hawkins (2006), US DoE H2A delivery model and Cerri I. et al (2012).

# Underground hydrogen storage is the preferred option for bulk storage applications

Like natural gas, hydrogen can be stored underground in several types of geological formation: deep aquifers, depleted oil and gas reservoirs, and rock-salt deposits. However, so far, hydrogen has only been successfully stored in rock-salt deposits. Underground storage is based on the compression and decompression of gas between a minimum and a maximum pressure, both derived from the initial formation pressure in the cavern<sup>1</sup>. The gross energy capacity of the cavern is determined by the maximum cavern pressure. The net energy capacity is lower due to the amount of cushion gas needed to maintain the minimum pressure in the cavern. *i.e.* gas that is not for use and must stay in the cavern. The maximum power rating for charging is limited by the injection rate of the well and bottlenecks in surface facilities. The maximum power rating for discharge is limited by the maximum admissible depressurization rate of the cavern (geological factor): an empirical rule of 10 bar of depressurization per day gives about 10% of discharge capacity per day.

Underground storage costs encompass both aboveground and underground facilities (figure 68). Above ground, a compressor is used to inject hydrogen into the cavern and reduce the pressure upon discharging so that it matches the pipeline's requirements. A dryer is sometimes needed to dry the gas, which can be saturated with water vapor from brine residues in the cavern. Underground costs include reservoir modeling, drilling, tubing and the casing of the injection well, the cementing of the borehole and the installation of safety valves. Salt caverns usually need to be created by pumping fresh or low-salinity water into a salt dome, creating a large quantity of brine for disposal.

Despite needing substantial initial investment, underground storage is the preferred option for large-scale, long-term applications. It allows unrivalled energy storage capacity, necessitates relatively low levels of compression (between 20 and 180 bar depending on the depth of the cavern, typically around 100) and requires a lower initial investment per unit of energy-storage capacity. The main problem for underground storage is locating suitable geological sites.

**Figure 68: Levelized cost of storage according to storage duration, with fixed rate of production<sup>2</sup>**  
\$/MWh

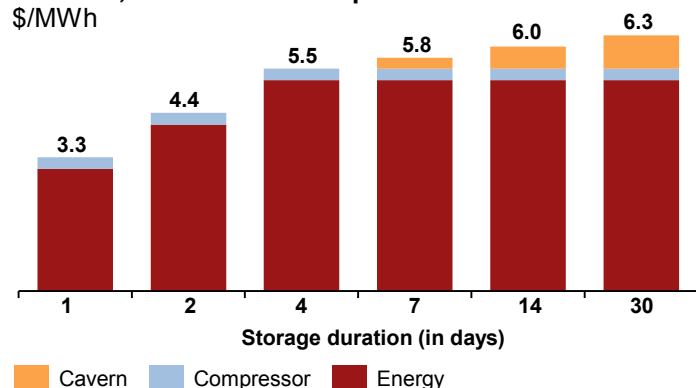

Size	GWh to several TWh
Efficiency	90-95% (including auxiliary systems and hydrogen losses)
Volumetric density	Typically 65 kWh <sub>ch</sub> /m <sup>3</sup> at 100 bar
Pressure	Typically 100 bar (20-180 bar depending on the cavern)
Injection/withdrawal rate	7% (injection) and 10% (withdraw) of total capacity per day
Capability for long-duration storage	High – with insignificant leakage –
Cycling rate	Low
Investment cost <sup>3</sup>	~\$1-3 /MW (compressor) / Salt cavern mining (\$23 /m <sup>3</sup> ) + cushion gas
Advantages over other hydrogen storage methods	<ul style="list-style-type: none"> <li>• High storage capacity</li> <li>• Low investment and operation costs</li> <li>• Small aboveground footprint</li> <li>• Needs low compression</li> </ul>
Drawbacks relative to other hydrogen storage methods	<ul style="list-style-type: none"> <li>• Low cycling rate and minimum capacity at ~ 1GWh</li> <li>• Depends on the availability of suitable geographical formation</li> <li>• Social resistance</li> </ul>

1. Maximum pressure is usually around 80% of the initial pressure at the top of the cavern & minimum pressure corresponds to 30% of the maximum pressure; 2. For storage duration of 7 days or more, cavern capital costs start to become significant, as H<sub>2</sub> throughput over the lifetime of the cavern decreases; 3. Capital costs depend to a significant extent on whether a suitable cavern already exists.

## Man-made salt caverns have proved to be a safe and efficient way of storing hydrogen but their uneven distribution has shifted R&D interest towards deep aquifers and depleted oil & gas fields

**Salt deposits are the only type of geological formation successfully used to store hydrogen underground to date** (figure 69). The salt keeps the cavern extremely gas-tight and does not react with hydrogen. This eliminates the risk, common to all underground hydrogen-storage projects, of the gas reacting with host minerals and micro-organisms, and causing leaks or reservoir blockages (see Section 4.2).

**Since these caverns are man-made, their size is largely customizable, albeit constrained by the dimensions of the salt formation** (mainly bedded salt or salt dome). Caverns can be created at depths ranging between 500 and 2,500 m, compared with 600-1,300 m in the case of compressed air energy storage. They can reach 500 m in height and 50-100 m in diameter, depending on the kind of salt formation. Salt caverns allow higher injection and withdrawal rates than naturally occurring formations (depleted oil & gas reservoirs and deep aquifers) and require lower proportions of cushion gas. As a result, cycling rates are higher.

**The shortage of suitable salt deposits, however, is a major hindrance to widespread use.** Salt formations are unevenly distributed throughout the world (figure 70) and are not necessarily located where large-scale, intermittent electricity storage is needed (see Box 5). Furthermore, not all salt formations are suitable for hydrogen storage. In Europe, salt formations best adapted for storage are mostly found in the North Sea (north-west of Germany, north-east of the Netherlands), but southern Germany and north-western France lack suitable deposits. The west coast of the US and Japan are also characterized by an absence of adequate formations. Comprehensive geological mapping (e.g. work package 3 HyUnder project) is needed to locate suitable salt formations globally.

**Research into alternatives to salt storage – i.e. natural reservoirs in deep aquifers and depleted oil & gas fields – is under way.** Several projects, notably Hychico in the Argentinian province of Chubut and H<sub>2</sub>STORE in Germany and France, are injecting hydrogen into depleted gas fields, and testing for leaks and reactivity with the host rock.

Figure 69: Illustration of a salt cavern<sup>1</sup>



Figure 70: Existing H<sub>2</sub>-caverns in salt domes<sup>2</sup>

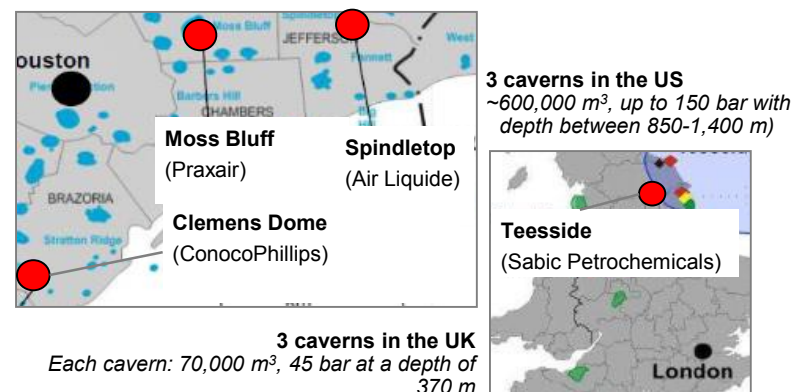

## Metal hydrides reduce the energy penalty incurred in processing and improve hydrogen-handling safety, but must still demonstrate their economic feasibility

**Certain metals bind very strongly with hydrogen, forming a metal hydride compound** (e.g.  $\text{Mg} + \text{H}_2 \rightarrow \text{MgH}_2$  Magnesium Hydrides). Under low temperature or at high pressure, hydrogen gas molecules adhere to the surface of the metal and break down into hydrogen atoms, which penetrate the metal crystal to form a solid metal hydride. Absorption is exothermic and cooling is required to optimize the absorption rate. This process is reversible: when the metal hydride is heated, the metal-hydrogen bonds break, and hydrogen atoms migrate to the surface where they recombine into hydrogen molecules. This desorption process is therefore endothermic (figure 71). In order to minimize the energy penalty, heat released during absorption can be captured and stored for use during desorption. The combined use of metal hydrides and thermal storage, known as adiabatic metal hydrides, is already on the market (e.g. McPhy's phase-change materials and Magnesium hydride solutions).

**The advantage of metal hydrides lies mainly in their low-pressure operating mode.** This avoids the need for compressing or liquefying electrolytic hydrogen, thereby reducing investment costs and energy losses. It is also safer than compressed gas or liquid hydrogen. Metal hydrides have a higher volumetric density than compressed or liquefied hydrogen, allowing up to 25 MWh to be stored in container-sized systems.

**Discovered decades ago, the development of metal hydrides was impeded by their high investment costs and slow charging/discharging rate, as well as the potential for heat loss.** Driven by attempts to facilitate safe hydrogen storage in fuel-cell-electric vehicles, interest in solid storage has been increasing since 2000, resulting in significant advances in kinetics. Additives and the nano-structuring of metals have been used to speed up absorption and desorption, and cost reductions have been made by favoring abundant and low-cost materials such as magnesium<sup>2</sup>. Notwithstanding these improvements, metal hydrides are too heavy and their charge times are too long for them to be used in mobility applications. For stationary applications, they are best suited to daily-to-weekly cycling systems of relatively large sizes (tens of MWh), where large compressed tanks would be too costly to run, and where underground storage is impractical. A 39 MWh storage facility set to be operational in 2014 in Italy will be a good indicator of the potential of metal hydrides.

**Figure 71: Principle of metal hydride hydrogen storage (left), and McPhy's metal hydride H<sub>2</sub> storage system (right)<sup>1</sup>**

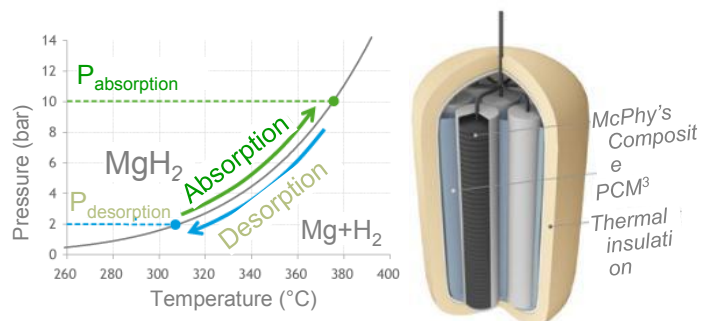

<b>Size</b>	0.1–25 MWh per standard shipping container
<b>Efficiency</b>	80–98% (including auxiliary systems and hydrogen losses)
<b>Volumetric density</b>	4,200 kWh <sub>ch</sub> /m <sup>3</sup> (106 kgH <sub>2</sub> /m <sup>3</sup> )
<b>Gravimetric density</b>	2–7wt.% H <sub>2</sub>
<b>Charge/discharge time</b>	A few hours to charge and discharge
<b>Capability for long-duration storage</b>	High – no leakage
<b>Investment cost</b>	Unknown
<b>Advantages over other hydrogen storage methods</b>	<ul style="list-style-type: none"> <li>• Safety / no hydrogen leakage</li> <li>• Larger energy capacity than compressed tanks</li> </ul>
<b>Drawbacks relative to other hydrogen storage methods</b>	<ul style="list-style-type: none"> <li>• Heavy</li> <li>• Long charging / discharging times</li> <li>• Low lifetime</li> </ul>

2. A project using a top-down approach for the fabrication of Mg-Based nanocomposite powders with large hydrogen-storage capacity, funded by the Kuwait Foundation for the Advancement of Science [KFAS], has achieved notably quick charging/discharging times and a high cycling time (up to 600 cycles without degradation); 3. PCM for phase-change material. Source: Image courtesy of <sup>1</sup>McPhy Energy; A.T. Kearney Energy Transition Institute interviews with organizations involved in hydride storage system.

## Liquid hydrogen storage incurs high investment and energy losses associated with the liquefaction process, and is likely to be limited to transport applications

Hydrogen can be stored in liquid form [LH<sub>2</sub>] by cooling hydrogen gas to cryogenic temperatures (-253°C) (figure 72). LH<sub>2</sub> benefits from having a lower operational pressure (~10 bar) and a higher volumetric density than pressurized tanks. Its gravimetric density is higher than that of metal hydrides, making liquid hydrogen the preferred storage solution in the space industry for fueling space shuttles<sup>1</sup>.

However, liquefying hydrogen is an energy-intensive process that typically requires between 25 and 40% of the chemical energy of the hydrogen being liquefied. Generally, refrigeration systems operate in three stages: first, a three-step propane refrigeration system cools the hydrogen from ambient temperature to about -103°C; then a multi-stage nitrogen expansion process cools hydrogen further, from -103°C to -196°C; and, finally, a multi-stage helium compression-expansion process cools it from -196°C to -253°C. New systems are being developed to reduce costs (e.g. magnetic and acoustic cooling).

Storage duration can be limited by boil-off. Cryogenic tanks slowly heat up, resulting in a typical boil-off rate of 0.1-0.5 % per day. Slow leakage must be permitted for safety reasons (to avoid the cryogenic vessel becoming over-pressurized when reheated to ambient temperature). Slow leakage may, however, be limited or eliminated by super-insulation systems that automatically capture boil-off gas (for instance via hydrides) and re-liquefy the fuel.

Therefore, due to high investment costs and energy losses, liquid hydrogen is unlikely to play a significant role in stationary hydrogen storage. It may be worth considering in the context of cryogenic transport if it involves large quantities transported over long distances and to numerous locations (see Section 3.2 case No. 3) or where there are no pipelines. For instance, Kawasaki is working on the feasibility study for a liquid hydrogen transport chain from Australia to Japan: the concept involves the gasification of 770 tons per day of hydrogen from brown coal (with carbon capture and storage), liquefaction, storage and shipping to Japan by two 5 TWh<sub>ch</sub> vessels.

**Figure 72: Levelized cost of storage according to liquefaction-plant size<sup>2</sup>**  
\$/MWh

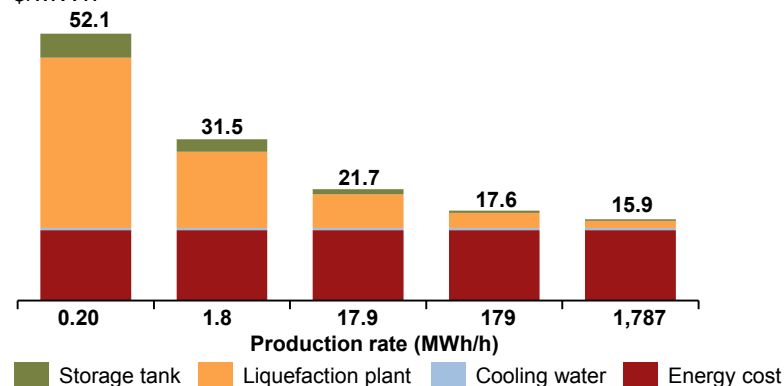

Size	0.1-100 GWh
Efficiency	55-75% (including auxiliary systems and hydrogen losses)
Volumetric density	1,400-1,600 kWh <sub>ch</sub> /m <sup>3</sup> (physical properties: 2,350-2,900 kWh/m <sup>3</sup> )
Gravimetric density	N/A
Temperature	< -253.15°C (20 Kelvin)
Capability for long-duration storage	Low – boil-off rate of 0.1-0.5% per day
Investment cost	\$800-10,000 /MWh (tanks) / M\$50 for 25 metric tons of H <sub>2</sub> /day – M\$250 for 200 metric tons of H <sub>2</sub> /day <sup>3</sup>
Advantages over other hydrogen storage methods	<ul style="list-style-type: none"> <li>• High energy density per volume and per mass</li> </ul>
Drawbacks relative to other hydrogen storage methods	<ul style="list-style-type: none"> <li>• High investments costs</li> <li>• High operational costs</li> <li>• Boil-off rate limits storage time to few days</li> </ul>

1. The National Aeronautics and Space Administration [NASA] has a liquid hydrogen reservoir of 3,800 m<sup>3</sup> in Cape Canaveral; 2. Based on electricity prices of \$50 /MWh; 3. According to U.S. DoE H<sub>2</sub>A delivery model with one metric ton = 39.39 MWh<sub>ch</sub> of H<sub>2</sub>.

## Driven by the need for hydrogen storage in mobility applications, research into advanced solid storage technologies is under way, but has not yielded significant results so far

The safe and economic storage of hydrogen in fuel-cell electric vehicles that meet refueling time and mileage requirements is considered to be one of the biggest impediments to hydrogen use in the mobility sector. As a consequence, R&D efforts have focused on specific mobility challenges, such as safety, in the case of a collision, and increasing volumetric and gravimetric density in order to compete with gasoline in long-range transportation. Yet, it is unlikely that these efforts will dramatically alter the outlook for storage in stationary applications, where cost remains the big problem.

**Figure 73: Single-walled carbon nanotubes**

Hydrogen gas is absorbed into porous carbon nanotubes (a good absorbent). The hydrogen uptake is proportional to the surface area and pore volume. Uncertainties remain regarding the gravimetric capacity of such materials, where the maximum capacity reached to date is around 2-3wt. % of H<sub>2</sub>.

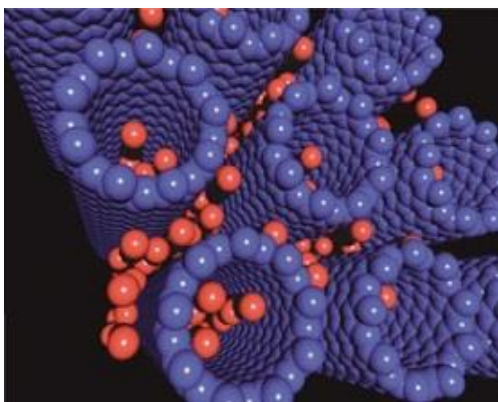

**Figure 74: Clathrate hydrates**

A Clathrate hydrate is a solid, crystalline compound framed by interlinked cages made up of hydrogen-bonded host water molecules. A second substance is added to stabilize the hydrate framework and significantly lower the hydrate-forming pressure. It can be stored at atmospheric pressure as long as the system temperature is maintained at 170 Kelvin or lower. It is still an unproved technology, but can reach a theoretical density up to 5 wt. % of H<sub>2</sub>

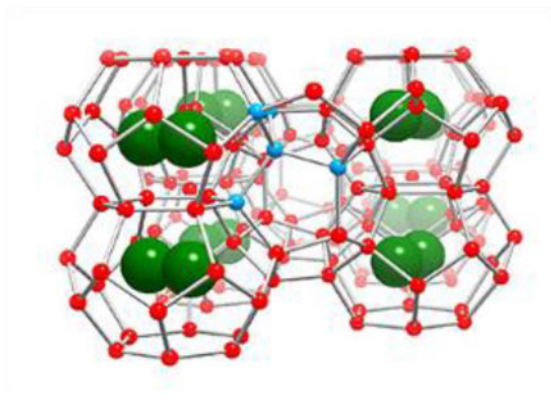

**Figure 75: Metal-organic frameworks**

Metal-organic frameworks are porous structures consisting of metal ions linked with organic molecules that can be used to store gases. They have low densities and high specific surface areas, which can be used to store hydrogen. Metal-organic frameworks can reach a gravimetric capacity of 8.6% per weight. of H<sub>2</sub> and a volumetric density of up to 44 kgH<sub>2</sub> /m<sup>3</sup> (for a pressure of 80 bar and temperature of 77 Kelvin). They are in the early research phase and still need to be proved.

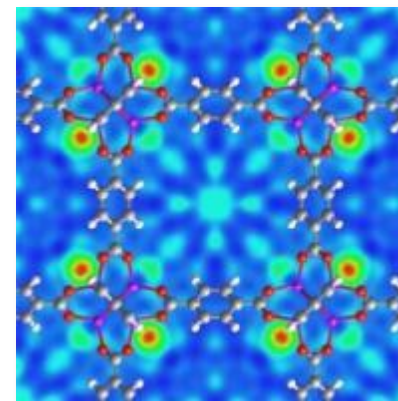

# Box 5: Suitable caverns for underground hydrogen storage

There are three types of underground reservoir suitable for hydrogen storage, described here in order of technical maturity:

### 1. Salt domes

The best option for underground hydrogen storage (and the only one that has been tried and tested) consists of caverns mined in thick salt formations, at depths of up to 2,000 m. Water introduced through pipes dissolves the salt, gradually creating a cavity. The cavern can reach a height of 300 to 500 m, a diameter of 50 to 100 m, and a volume of up to 1,000,000 m<sup>3</sup>. The amount of hydrogen stored depends on the pressure, which can reach values of up to 180 bar (storing around 500 GWh<sub>ch</sub> of hydrogen). It takes several years to mine a salt cavern and an environmentally friendly way of disposing of large volumes of brine is required. This host rock has a triple advantage over other geological formations: it allows a better cycling rate, needs only a small amount of cushion gas and its components do not react with hydrogen, avoiding gas poisoning..

### 2. Depleted oil & gas fields

The pore space of permeable rock formations sealed by a closed surface layer in depleted oil and gas fields makes them ideal candidates for high-volume underground storage. Their tightness has been proved over millions of years, lowering geological risk to a minimum. However, the need for a large amount of cushion gas and the risk of hydrogen contaminating other substances in the cavern (rocks, fluids and microorganisms) are significant barriers to progress and must be addressed.

### 3. Aquifers

The storage of hydrogen in aquifers remains an immature concept. These structures require additional exploration, which is usually costly. Aquifers present the highest potential in volume to store hydrogen. However, risks related to pressure losses when hydrogen is injected at a high rate and the potential for the various components of the reservoir (rocks, fluids and microorganism) to react with hydrogen may deter development.

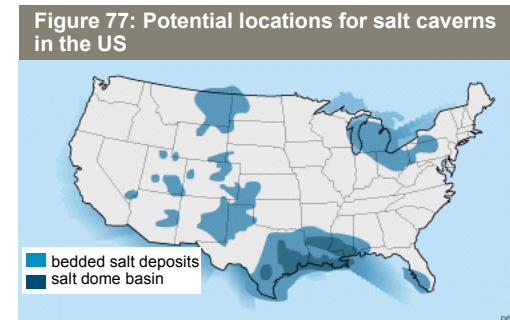
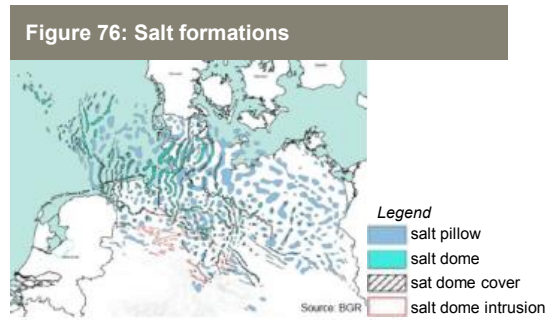

Figure 78: Qualitative comparison of the three H2 underground storage options

	Capacity	Cycling rate	Costs	Risk	Reactions with H <sub>2</sub>	Cushion gas
Salt caverns	Medium	High	High	Low	Low	Low
Depleted O&G fields	High	Medium	Low	Medium	High	High
Aquifers	High	Low	Medium	High	High	High

## Hydrogen transport incurs limited energy losses above and beyond those incurred during processing, but is a costly operation that could be largely avoided by decentralizing hydrogen production

In many cases, integrated electrolytic hydrogen projects are designed to avoid hydrogen transport because of its high cost<sup>1</sup>. In these decentralized projects, electrolyzers, H<sub>2</sub> storage and end-use are located on the same site (see Section 2.8 for project layouts). However, limitations to the layout (e.g. congestion in the power network, storage-site availability), may mean some hydrogen transport is required.

Hydrogen transport is already standard practice for industrial gas merchants, such as Air Liquid, Praxair, Linde and Air Products. They use three main transport methods: compressed tanks, cryogenic tanks, and pipelines. Tanks may be transported by road, rail or ship, although the last two are seldom used today.

The relative competitiveness of one option over the other depends on the desired transport flow rate and distance (figures 79 and 80). The choice of transport method is also constrained by the infrastructure in place (the existence of pipelines and the type of end-user facility) and by the types of processing and storage technology, if transport was not taken into account at the initial design stage<sup>2</sup>. In general:

- **Compressed tanks** have a low capacity per truck, which makes them mostly suitable for low throughput rates (below 5 MW<sub>ch</sub>, i.e. 120 MWh<sub>ch</sub> transported per day). Their economics are also highly sensitive to variable costs – particularly fuel and labor – which increase linearly with distance, so that liquefied tanks would become increasingly economic where distances run into the hundreds of km.
- **Cryogenic liquid tanks** can transport, on average, six times more energy per truck than tube trailers. However, the investment is also significantly higher if the initial liquefaction cost is taken into account. They are the preferred option for very long-range delivery, especially to multiple consumption sites.
- Pipelines can provide a low-cost option for point-to-point delivery of large volumes of hydrogen. However, it lacks the flexibility of road tanks for distributed delivery (e.g. to multiple H<sub>2</sub> refueling stations). In addition, the bulk of costs are related to pipe-laying and are, therefore, up-front costs – a barrier to the expansion of hydrogen pipelines in view of current demand for hydrogen transport. An alternative could be to adapt natural gas infrastructure to accommodate H<sub>2</sub> (Section 2.4).

**Figure 79: Levelized cost of hydrogen transported<sup>3</sup>**  
\$/MWh of hydrogen transported

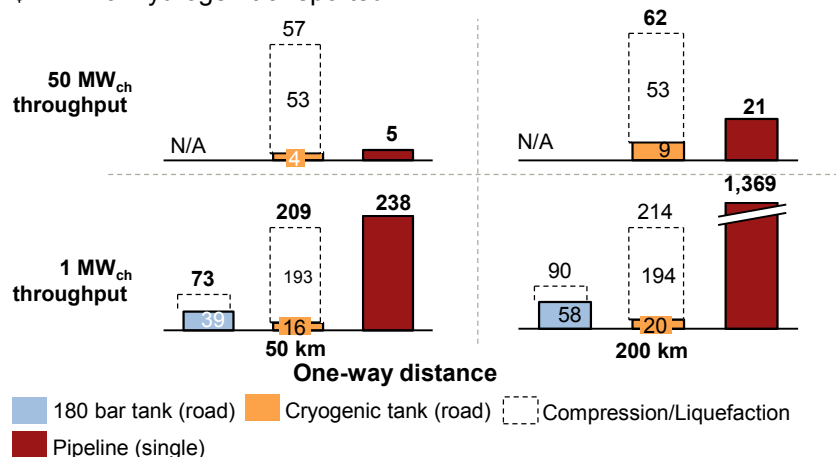

**Figure 80: Lowest-cost H<sub>2</sub> transport option according to distance and throughput<sup>4</sup> (MW<sub>ch</sub>)**

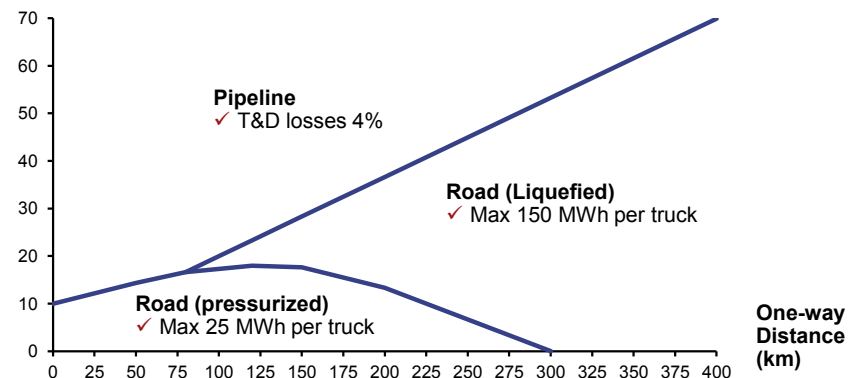

1. From production of hydrogen by electrolysis to end-uses; 2. e.g. if hydrogen storage is in the liquid phase, the gas will probably be transported in liquid tankers; 3. Point-to-point delivery, one-way distance in km. N/A when costs are unsustainable; 4. Point-to-point delivery.

Source: A.T. Kearney Energy Transition Institute analysis, based on US DoE H2A delivery model; Yang et al. (2006).

## Compressed tank transport is the preferred option for short distances and small throughputs

**Industrial gas merchants transport compressed hydrogen by truck for delivery to various small customers** located up to 300 km away from their production sites. Tanks are steel cylinders that can withstand pressures of 200 to 600 bar. Tanks are stacked into a truck trailer to be transported by road. The largest trailer (able to carry 40 tons) can transport up to 650 kg (25 MWh) of hydrogen (*i.e.* 1-2% of the total weight of the trailer).

The levelized cost of transport by compressed tanks (figure 81) is made up of initial costs (compressor, tanks and trucks) and variable costs (fuel, drivers and maintenance). Variable costs increase linearly with distance and are significantly affected by stand-by time, when the tank is stored on the client's site. Doubling the frequency of delivery reduces levelized costs up to a certain distance, when the added operational cost becomes too high (figure 82). Due to the limited quantity of hydrogen transported, **this option would not be suitable for supplying large refueling stations, which would require an excessive number of truck delivery trips per day.**

**Research is in progress to increase the capacity of the trucks by using larger, lighter and more robust tubes, made of composite materials.** Several designs are being investigated by US DoE and Lawrence Livermore National Laboratory, such as high-pressure cylinders (up to 700 bar) that would avoid the need for compressors at the end-use site (*e.g.* refueling stations), and cryo-compression (a combination of cooled and compressed hydrogen).

**Figure 81: Levelized cost of compressed hydrogen transported by road trailers<sup>1</sup>**  
\$/MWh

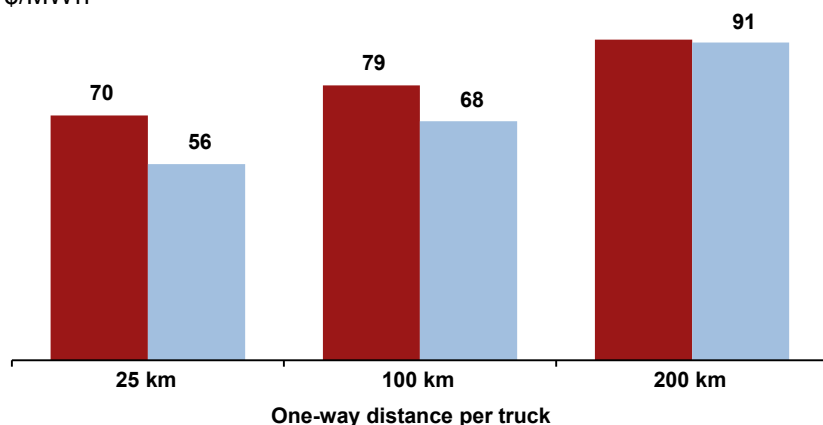

■ 1 MW throughput - 1 delivery of 24 MWh per day  
■ 2 MW throughput - 2 deliveries of 24 MWh per day

1. Includes costs of compression and related energy losses; based on SuperJumbo trailers with 9 tubes that can hold 25 MWh (650 kg) of hydrogen at 480 bar, with a maximum of two deliveries a day.

Source: A.T. Kearney Energy Transition Institute analysis, based on US DoE H2A delivery model; 2Hawkins (2006).

**Figure 82: Key facts for hydrogen transport in compressed tanks on road trailers<sup>2</sup>**

<b>Size</b>	Up to 25 MWh <sub>ch</sub> per truck (650 kg H <sub>2</sub> )
<b>Energy efficiency</b>	95% for a round-trip distance of 120 km, due to fuel use and losses from filling & discharging the tank. Compression losses are not taken into account
<b>Advantages</b>	<ul style="list-style-type: none"> <li>• Easiest method for transport</li> <li>• Distributed delivery: can deliver to multiple customers or to new customers before they are connected to a pipeline</li> </ul>
<b>Drawbacks</b>	<ul style="list-style-type: none"> <li>• Low capacity per trailer implies heavy truck traffic</li> </ul>

## Cryogenic tank transport is only competitive where hydrogen throughput is extremely large and for long-distance deliveries

Hydrogen can be transported in its liquid form at low pressure when cooled to  $-253^{\circ}\text{C}$  in order to increase its energy density. With this method, up to 4,000 kg of hydrogen ( $\sim 150$  MWh) can be transported in a 40-ton truck at ambient pressure (figure 83). Liquid hydrogen benefits from lower operational transport costs than compressed hydrogen transport, enabling longer-distance transport (figure 84). Six times more hydrogen can be transported in liquid form, making the variable costs of this form of transportation, such as driver and fuel costs, six times lower per unit of hydrogen transported. A long transport range is not only needed in cases where hydrogen is being produced at a remote site, but also for distributed delivery from a centralized hydrogen plant to multiple hydrogen-consumption sites, such as a network of  $\text{H}_2$  refueling stations spread over a wide area (see Section 3.2, business case No. 4).

However, the cost of liquefaction can only be justified if the throughput of hydrogen is very large. As in the case of cryogenic hydrogen storage, the main challenge for liquid hydrogen transport lies in the liquefaction stage. Liquefaction plants, which require very high initial investment, have significant scaling effects both on capital costs and energy efficiency.

Although liquid hydrogen would become more attractive if hydrogen demand were to increase, it is unlikely to play a major role in the short term for hydrogen produced from temporary excesses of electricity produced from renewable energy sources. Today, only three liquefaction facilities are operating in Europe, and 10 in the US. None of them uses electrolytic hydrogen. Looking ahead to 2025, a study has demonstrated the economic feasibility of the overseas transport of liquid  $\text{H}_2$  by marine vessel; it compares the cost of producing hydrogen from renewable electricity in Japan with the cost of producing clean hydrogen from coal in Australia, capturing the carbon, storing the hydrogen and shipping it to Japan<sup>1</sup>. Rail delivery has also been investigated in the U.S. and is thought to involve comparable costs to truck transportation; as such, it has the potential to open up remote renewable resources to development<sup>2</sup>.

**Figure 83: Levelized cost of liquid hydrogen transported by road trailers<sup>3</sup>**  
\$/MWh

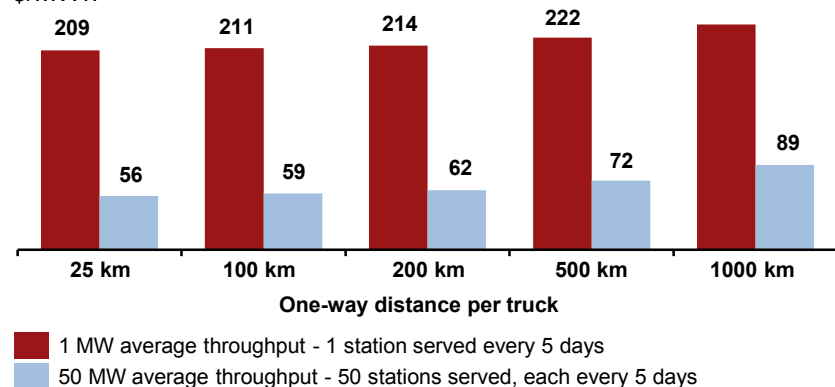

**Figure 84: Key figures for hydrogen transport in cryogenic tanks on road trailers<sup>3</sup>**

<b>Size</b>	Up to 150 MWh <sub>cn</sub> per truck (4,000 kg H <sub>2</sub> )
<b>Energy efficiency</b>	99.7% for a round-trip distance of 120 km, due to fuel use and losses from filling & discharging the tank. Liquefaction losses are not taken into account
<b>Advantages</b>	<ul style="list-style-type: none"> <li>Road transport for larger quantities than tube trailer</li> <li>Distributed delivery: can deliver to multiple customers or to new customers before they are connected to a pipeline</li> </ul>
<b>Drawbacks</b>	<ul style="list-style-type: none"> <li>Liquefaction plants only economic at tens of MW scale</li> <li>Boil-off rate requires rapid delivery of liquid hydrogen</li> </ul>

2. See Section 3.2, business case No. 3; 3. Includes the costs of liquefaction and related energy losses. Based on tankers that can hold 150 MWh (4,000 kg) of hydrogen, with 2 maximum deliveries per day.

## Pipelines are the cheapest option for point-to-point transport of large quantities of hydrogen, but face the traditional “chicken-&-egg” dilemma associated with costly new infrastructure

**Large industrial players transport hydrogen by pipeline. More than 1,600 km of pipelines have been constructed in Europe** (mainly in the Netherlands, Belgium, northern France, Germany and the UK) **and 1,100 km in the US** (Texas and Louisiana). There are smaller networks in Brazil, Thailand, South Korea and South Africa, varying in length between less than a kilometer to hundreds of kilometers. Pipelines usually operate at pressures between 40 and 70 bar and have diameters of between 0.5 and 20 inches (1.3-50 cm). They are mainly made of low-carbon steel alloys, and protected from embrittlement and corrosion by plating and coating processes. Pipeline transport theoretically requires initial compression, but this is often unnecessary, as the gas has usually already been compressed for storage. However, fewer compressor stations than are required in natural gas pipeline transmission are needed along hydrogen pipelines to drive the flow of gas, as the lower viscosity of hydrogen results in lesser friction losses.

**Pipeline construction is expensive and made up of three main elements:** materials (15-35%, depending on the pipeline’s diameter and the construction material), construction (40-50%, including labor costs), planning & miscellaneous (20-30%, including engineering, financing and rights of way). Costs vary according to distance and flow rate, and range approximately between \$0.3 and \$1.5 million per kilometre (10% more than the cost of a natural gas pipeline).

**However, as a result of economies of scale, the levelized cost of transport per unit of hydrogen is relatively low for high H<sub>2</sub> throughput** (figure 85). Therefore, pipelines are the cheapest option for transporting large quantities of hydrogen to supply continuous demand. Their inner volume can also act as buffer storage for managing small fluctuations in hydrogen injection and withdrawal rates (see Section 2.4 on linepack storage).

**Because initial investment makes up most of the levelized cost, pipelines are hard to justify economically for discontinuous operations or transitional periods** (i.e. when demand is not high or sufficiently regular). This gives rise to hydrogen infrastructure’s *chicken-and-egg* dilemma.

**Figure 85: Levelized cost of hydrogen transported by pipeline<sup>1</sup>**  
\$/MWh

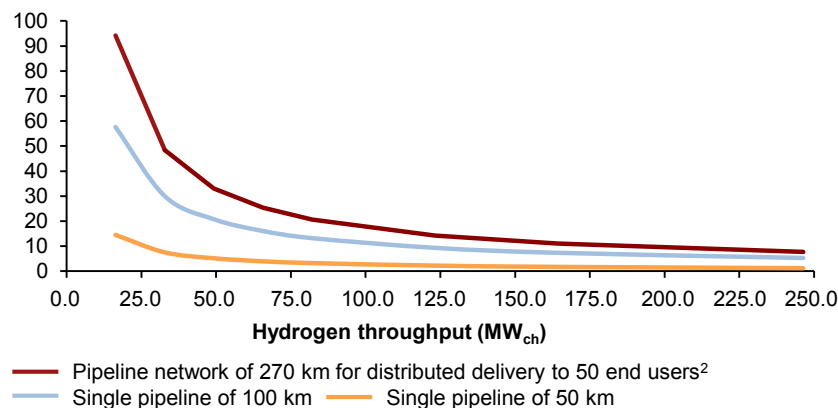

1. Compressor costs needed along the pipeline are included. Pipeline diameter is calculated according to the flow rate, based on natural gas models. Levelized costs are calculated based on continuous operations. 2. Assumes a pipeline network with one transmission pipeline of 50 km, 2 trunk pipelines of 50 km, and 50 distribution pipelines of 2.4 km.

2. Source: A.T. Kearney Energy Transition Institute analysis, based on US DoE H2A delivery model; 3Yang et al. (2006).

**Figure 86: Key figures for pipeline transport of hydrogen<sup>3</sup>**

<b>Flow rate</b>	No technical limitations
<b>Energy efficiency</b>	94 – 99% (including pressure losses and compressors along the pipeline)
<b>Advantages</b>	<ul style="list-style-type: none"> <li>• Lowest cost option for continuous delivery</li> <li>• Very low operational costs</li> <li>• Can act as buffer storage for hydrogen</li> </ul>
<b>Drawbacks</b>	<ul style="list-style-type: none"> <li>• High capital costs to deploy the infrastructure needed</li> <li>• High market penetration of hydrogen required for the use of pipelines to make economic sense</li> </ul>

## Overall, hydrogen storage and transport may add significant costs to electrolytic hydrogen projects

Despite being the most mature segment of the value chain, hydrogen handling between production and end-use can add a significant cost to integrated electrolytic hydrogen projects. This largely results from the 'packaging' of hydrogen – in the form of compression, liquefaction or absorption – to increase its energy density per volume. In the short to medium term, compressed hydrogen is likely to be the predominant solution. Nonetheless, the levelized cost of hydrogen delivery depends to a large extent on project layout (project size, transport distance, transport type...). Figure 87 illustrates an example of this.

**Decentralized production avoids transport costs** (layout 1) if the power grid extends to the hydrogen consumption-site. Nevertheless, local compression and storage often remains necessary. The size of this buffer (one day in our example) depends on the end-use of H<sub>2</sub> (e.g. negligible buffer for power-to-gas, see Section 2.4) and determines the levelized cost of storage to add to that of H<sub>2</sub> production.

**Centralized production and delivery might be an economic alternative** if underground storage is feasible (layout 3). Centralized storage in compressed tank is no less expensive than decentralized storage (layout 2). Liquid hydrogen might be relevant if needed at the consumption-site (layout 4); otherwise, additional storage costs at the consumption site must be added to this analysis.

However, no conclusion should be made on optimal project layout without assessing the economics of the entire value chain, from power to H<sub>2</sub> delivery (see Section 2.8). H<sub>2</sub> production costs are generally higher in decentralized systems because of (i) cost-scaling effects on the electrolyzer plant and (ii) higher electricity costs due to distribution fees.

**Figure 87: Levelized cost of hydrogen delivery (processing, storage and transport) to 50 end-use sites of 1 MW<sub>ch</sub> each - four different layouts compared**

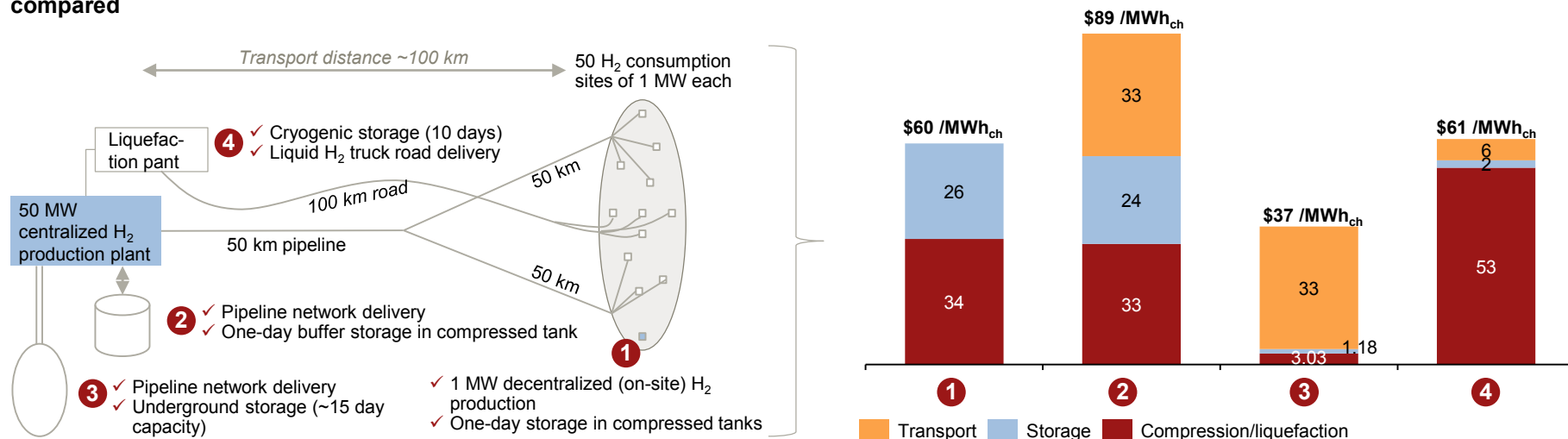

The pipeline network consists of one 50 km transmission pipeline, two 50 km trunk pipelines and 50 2.4 km distribution pipelines connecting the grid to end-consumers. The levelized cost is calculated using the assumptions previously stated in this section.

Source: A.T. Kearney Energy Transition Institute analysis, based on US DoE H<sub>2</sub>A delivery models.

## Sources: section 2.2

- Cerri et al. (2012), “*Scientific assessment in support of the materials roadmap*”, Isota Cerri, Florence Lefebvre-Joud, Peter Holtappels
- Crotogino et al. (2010), “*Large-Scale Hydrogen Underground Storage for Securing Future Energy Supplies*”, Fritz Crotogino, Sabine Donadei, Ulrich Büniger, Hubert Landinger, proceedings of the 18<sup>th</sup> World Hydrogen Energy Conference
- Di Profio et al. (2009), “*Comparison of hydrogen hydrates with existing hydrogen storage technologies: Energetic and economic evaluations*”, Pietro Di Profio, Simone Arca, Federico Rossi, Mirko Filippini, International Journal of Hydrogen Energy, vol. 34, pp. 9173-9180
- Eurogas (2010), “*Eurogas Statistical Report 2010*”
- Furukawa et al. (2013), “*The Chemistry and Applications of Metal-Organic Frameworks*”, Hiroyasu Furukawa, Kyle E. Cordova, Michael O’Keeffe, Omar M. Yaghi, Science, vol. 341
- Hawkins (2006), “*Technological characterization of hydrogen storage and distribution technologies*”, Sam Hawkins
- Heung (2003), “*Using metal hydride to store hydrogen*”, Leung K. Heung, Savannah River Technology Center
- Hydrogenics (2011), “*Hydrogen Energy Storage for Intermittent Renewables sources*”
- HySafe (2007), “*Biennial Report on Hydrogen Safety (Version 1.0.1)*”, Hydrogen fundamentals p. 1
- International Energy Agency – IEA (2007), “*Energy technology essentials - Hydrogen production & distribution*”
- International Energy Agency – IEA (2012), “*World Energy Outlook 2012*”
- Kawasaki Heavy Industries, Ltd (2012) “*Feasibility Study of CO2 free hydrogen chain*”; Kenji Yoshimura; 15 November 2012; [http://www.iphe.net/docs/Events/Seville\\_11-12/Workshop/Presentations/Session%203/3.3\\_IPHE%20Workshop\\_Yoshimura.pdf](http://www.iphe.net/docs/Events/Seville_11-12/Workshop/Presentations/Session%203/3.3_IPHE%20Workshop_Yoshimura.pdf)
- KBB Underground technologies (website), <http://www.kbbnet.de/en/>
- Leighty (2007) “*Running the World on Renewables: Hydrogen Transmission Pipelines with Firming Geologic Storage*”, William C. Leighty, International Journal of Energy Research, vol. 32, pp. 408-426
- McPhy Energy, <http://www.mcphy.com/>
- Steward et al. (2009), “*Lifecycle cost analysis of hydrogen versus other storage options*”, National Renewable Energy Laboratory
- Raine et al (2009), “*Analysis of the current hydrogen cost structure*”, Diana Raine, Robert Williams, Air Products; Hilde Strøm, StatoilHydro
- Roads2HyCom, “*Hydride Hydrogen Storage*”, RWTH Aachen University
- United States Department of Energy – US DoE, The Hydrogen Analysis (H2A) Project, Hydrogen and Fuel Cell Program, [http://www.hydrogen.energy.gov/h2a\\_analysis.html#h2a\\_project](http://www.hydrogen.energy.gov/h2a_analysis.html#h2a_project)
- Yang et al. (2006) “*Determining the lowest-cost hydrogen delivery mode*”, Christopher Yang, Joan Ogden, International Journal of Hydrogen Energy, vol. 32, pp. 268–286

## 2.3 - Hydrogen-to-electron: fuel cells & combustion turbines



## Summary & key findings: section 2.3

1. **Hydrogen conversion into electricity has poor energy efficiency**, ranging from 30% to 60%, according to the technology used (fuel cells or turbines). Combined with the energy penalty from using electrolyzers, these re-electrification losses result in a round-trip efficiency ranging from 20%, to, at best, 48%, if technology develops as expected. In order to compete directly with other electricity storage solutions, the efficiency penalty needs to be compensated for by hydrogen's unique ability to store energy.
2. **Recovering heat losses from re-electrification is essential** to improve the energy efficiency of the system and lower the levelized cost of electricity delivered. Heat losses could be recycled in two ways: (1) for heating purposes, within combined heat and power [CHP] applications. Heat is very hard to transport over long distances, which is why micro CHP fuel-cell systems for decentralized applications are an important part of today's fuel-cell-system installation. The energy efficiency of hydrogen-to-CHP should be able to reach 75%; and (2) converted into electricity in a combined-cycle power plant to increase the electricity efficiency of continuous operations. High-temperature waste heat and a large-scale system are required to compensate for increased capital costs, limiting this application to gas turbines or high-temperature fuel cells.
3. **Fuel cells and combustion turbines do not compete directly for the same application:**
  - Fuel cells prioritize reliability/autonomy /low maintenance (e.g. back-up systems, uninterrupted power supply), at the expense of capital costs per kW; and
  - H<sub>2</sub> turbines will be stationary and no smaller than ~10MW, due to the economies of scale available. That contrasts with highly modular fuel cells.
4. **Fuel cells have long been under development, driven by the promise of fuel-cell-electric vehicles.** They are now in the early commercialization phase (505 MW<sub>e</sub> installed as of end-2012, 33% compound annual growth rate over the last five years), increasingly pushed by stationary applications (55% of the capacity sold in 2012). Only a negligible portion (2.5 MW<sub>e</sub>) of these stationary fuel cell plants is sourcing hydrogen from electricity. Because the technology in fuel cells and electrolyzers (PEM and SOEC) is basically the same, the issues are similar: manufacturing costs and lifetime. Fuel cells are generally slightly less efficient than electrolyzers, but technically more mature.
5. **Five different types of fuel cells have been developed**, grouped into low- and high-temperature categories:
  - The hydrogen-to-electricity efficiency of low-temperature fuel cells (of which proton exchange membrane [PEM] is the most promising) are limited to 32% at present. The PEM fuel cell is the only candidate for mobility and has always been the most manufactured fuel-cell type. It is also fit for stationary applications, and a popular choice for grid-control services because of its reactivity; and
  - High-temperature fuel cells are generally more efficient (up to 50%), and well suited to stationary CHP systems of megawatt scale. They are commercially available with decent lifetimes (unlike high-temperature electrolyzers), but remain very expensive to manufacture. Solid-oxide fuel cells are particularly promising, as they can easily be reversed to become electrolyzers and can operate using H<sub>2</sub>, syngas, methane or methanol.
6. **Gas turbines can also be used to burn hydrogen** – essentially a fuel gas; the hydrogen can be pure or mixed with natural gas or syngas. Flexible syngas turbines are able to operate with an undifferentiated mix of H<sub>2</sub> and CO with up to 70% hydrogen in mass. They have recently been commercialized for coal-gasification power plants; 100%-hydrogen turbines remain in the early demonstration phase because of limited demand, but would pose only moderate technical issues. Slightly different turbine designs are necessary to cope with the specificities of hydrogen, but the balance of plant would remain quite similar.

# Stored hydrogen can be used to reproduce electricity using fuel cells or gas turbines

**Hydrogen can store electricity for future re-conversion** through (i) electrochemical fuel cells, or (ii) thermal gas turbines (figure 88).

**Fuel cells convert chemical energy directly into electrical energy by the reverse process to that of electrolysis:** hydrogen gas reacts with oxygen to produce water and an electrical current. Unlike combustion in gas turbines, electro-chemical reactions produce electricity directly and do not require any moving parts, which makes fuel cells more reliable. Similarly to electrolyzer cells, fuel cells are highly modular (they are composed of stacked cells) and can supply a broad range of power applications, from small portable equipment to megawatt bulk generation. There are five main types, categorized according to their operating temperature and the chemical composition of their electrodes and electrolytes.

**Hydrogen, which is essentially a fuel gas, can also be used in combustion turbines.** Combusting hydrogen with oxygen generates water and heat. Heated vapor is fed into a turbine to produce mechanical energy, which, in turn, is converted into electricity by a generator. Although pure hydrogen turbines have been investigated as a means of extracting energy from hydrogen gas, hydrogen is most likely to be blended with natural gas for use in conventional gas turbines and cover the same range of power capacities (*i.e.* from several hundred kilowatt to hundreds of megawatts). However, hydrogen mixed with natural gas can increase risks and damage materials. For example, due to the highly flammable nature of hydrogen, there is a risk of flame flashback and overheating, which could also lead to increased nitrate oxide emissions and performance losses. Furthermore, steel is susceptible to hydrogen embrittlement, which could damage the turbine and cause accidents. Turbine manufacturers estimate that blending 1% to 5% in volume would not require any changes, but that higher proportions of hydrogen would probably require specially adapted combustion hardware and control systems, as well as new safety regulations.

**Fuel cells and combustion turbines are not competing for the same applications.** Fuel cells are much more suited to decentralized designs (*e.g.* for powering cars), whereas turbines are more suited to large-scale centralized requirements (figure 89).

**Figure 88: Energy forms in the two re-electrifications pathways**

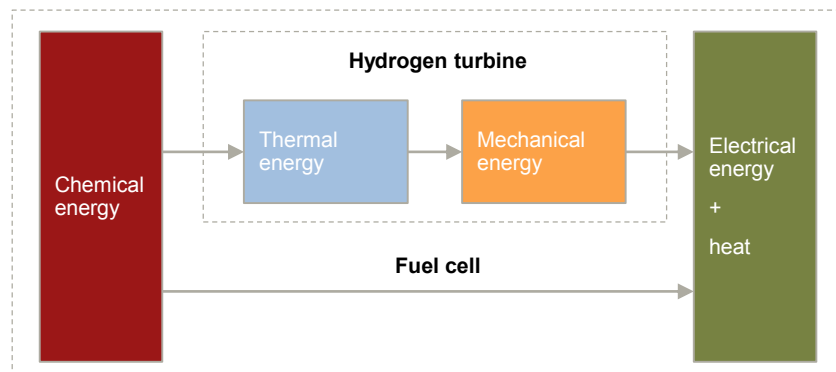

**Figure 89: Power range and applications of hydrogen re-electrification**

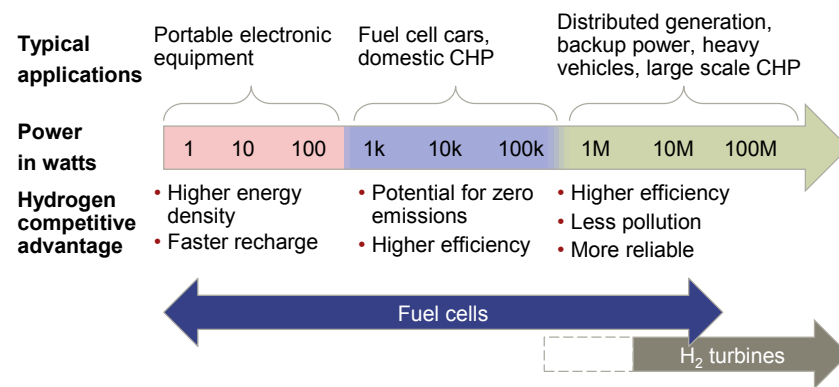

## Hydrogen re-electrification results in poor round-trip efficiency, which is likely to impede its development in the short term (1/2)

The practical efficiency range of hydrogen-to-electricity lies between 30% and 60%, according to the technology used<sup>1</sup> (figure 90). Efficiency is about 30% for low-temperature fuel cells, 45% for H<sub>2</sub> turbines run in open cycle, 50% for high-temperature fuel cells (solid-oxide fuel cells [SOFC]), and up to 60% for H<sub>2</sub> turbines run in combined cycle, where hot exhaust vapor from the gas turbine is re-used to drive a steam turbine, improving efficiency at the expense of flexibility. The efficiency of an H<sub>2</sub> turbine is slightly better than that of a natural gas turbine.

Combined with the electrolyzer energy penalty, the round-trip efficiency of an H<sub>2</sub>-based storage system is very low. Round-trip efficiency is the product of the efficiency of electrolysis, storage and re-electrification. It ranges from 20%, to, at best, 48%, if technology develops as expected. In any case, it is significantly lower than the round-trip efficiency of all other large-scale storage technologies, such as pumped hydro storage (70-85%), compressed-air energy storage (45-85%) or flow batteries (60-85%).

Recovering heat losses from re-electrification in combined heat and power [CHP] applications improves the energy efficiency of the system. Depending on the fuel cell and turbine technologies, re-using waste heat can raise the efficiency of hydrogen-to-useful energy (heat & power) to 76% today (and to 80% in the future). The corresponding highest-achievable round-trip CHP efficiency with underground H<sub>2</sub> storage is 56% today (65% in the future). In practice, re-using waste heat relies on the existence of demand for heat<sup>2</sup>, which can have a different demand profile to that of electricity.

Efficiency issues aside, fuel cells suffer from high investment costs and short lifespans. Their use is, therefore, limited to applications that have low maintenance requirements and that prioritize reliability (e.g. back-up systems, uninterruptible power supply). For other applications, turbines are probably the preferred option in the short-to-medium term, as they are less costly.

Figure 90: Comparison between fuel cells and hydrogen turbines

	Applications	Hydrogen-to-electricity efficiency (HHV)	Hydrogen-to-CHP efficiency (HHV)	Investment cost	Lifetime (in CHP cycle)	Advantages	Drawbacks
<b>Low temperature fuel cells<sup>3</sup></b>	<ul style="list-style-type: none"> <li>Back-up power</li> <li>FCEV</li> <li>Micro-CHP generation</li> </ul>	32% (PEMFC) <sup>3</sup> 45% (PAFC)	72%	< \$3,200 /kW <sub>e</sub> for a PEMFC with CHP	Up to 10,000 hours before partial replacement	<ul style="list-style-type: none"> <li>Low start-up time</li> <li>Commercially available</li> </ul>	<ul style="list-style-type: none"> <li>Low efficiency</li> <li>High cost</li> <li>Low lifetime</li> </ul>
<b>High temperature fuel cells</b>	<ul style="list-style-type: none"> <li>Distributed power generation</li> <li>Auxiliary power units</li> </ul>	50%	76% (today) 80% (future)	< \$3,200 /kW <sub>e</sub> for a SOFC with CHP	Up to 15,000 hours before partial replacement	<ul style="list-style-type: none"> <li>Good efficiency with CHP</li> <li>Fuel flexibility (also works with methane)</li> <li>Commercially available</li> </ul>	<ul style="list-style-type: none"> <li>High cost</li> <li>High start-up time</li> <li>Low lifetime</li> </ul>
<b>Hydrogen turbines</b>	<ul style="list-style-type: none"> <li>Large scale re-electrification</li> </ul>	45% (open cycle) 60% (combined cycle)		\$1,000 /kW <sub>e</sub> (open cycle)	20 years (300,000 hours)	<ul style="list-style-type: none"> <li>Lower costs</li> <li>High efficiency</li> <li>High lifetime</li> </ul>	<ul style="list-style-type: none"> <li>Pilot scale</li> <li>Cannot be scaled down</li> </ul>

1. Measured in higher heating value [HHV]; 2. district heating network or industrial process heat; 3. The efficiency of PEM fuel cells may be inferior to the performance of other types of fuel cells when they use natural gas as feedstock; PEMFC: proton exchange membrane fuel cell; PAFC: phosphoric acid fuel cell.

Source: A.T. Kearney Energy Transition Institute analysis; Cerri et al. (2012); Ball et al. (2009); US DoE (2011); Larminie et al. (2003); Fusina hydrogen power plant for open cycle H<sub>2</sub> turbine.

## Hydrogen re-electrification results in poor round-trip efficiency, which is likely to impede its development in the short term (2/2)

Figure 91 illustrates the losses that occur along the hydrogen value chain and compares them with current commercial technology for large-scale electricity storage (pumped hydro storage [PHS] and compressed-air energy storage [CAES]). **Clearly, H<sub>2</sub>-based systems are among the least electrically efficient. The competitiveness of such systems will depend on their other attractions:** their unrivalled energy storage capacity compared with PHS or CAES, and the ability to use waste heat for combined heat and power, to transport hydrogen and to decouple storage capacity (kWh) from power capacity (kW). (see Section 3.2 for a selection of business-case analyses on H<sub>2</sub>-based electricity storage systems.)

**Figure 91: Losses along the stored hydrogen re-electrification value chain<sup>1</sup>**  
MWh, Based on a 100 MWh storage system with no hydrogen transport

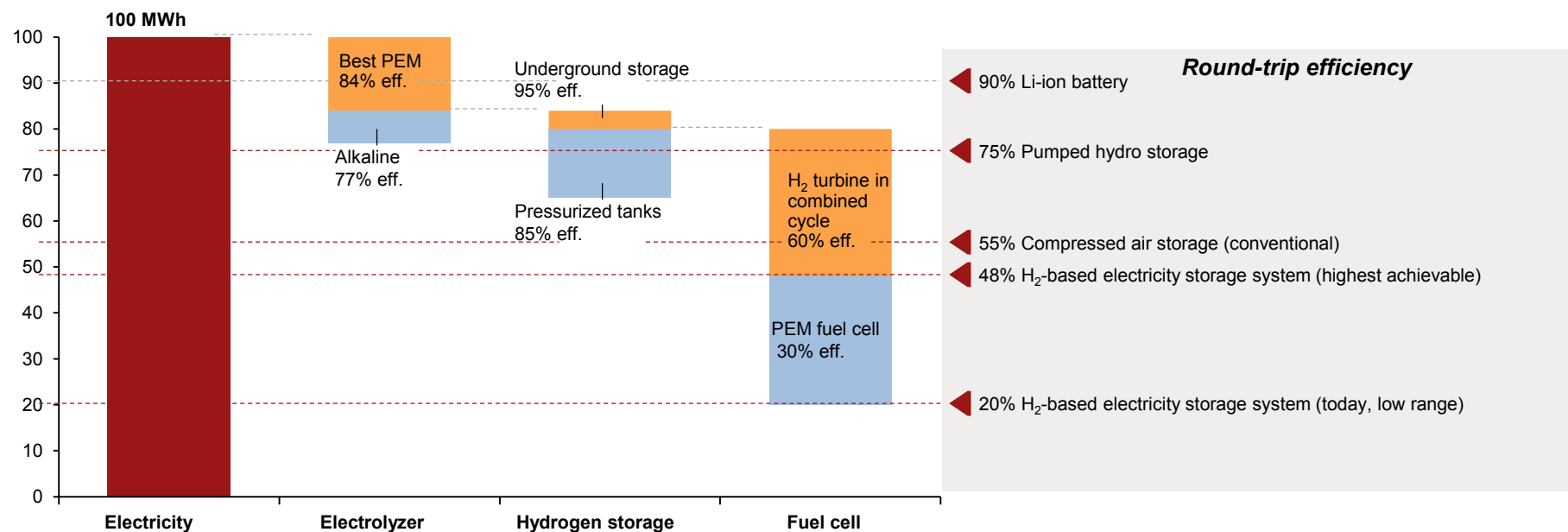

1. The waterfall presents the maximum range of best mid-term efficiencies together (84% for electrolyzers, 95% for storage, and 60% for re-electrification) and lowest current efficiencies combined (77% for electrolyzers, 85% for storage and 30% for re-electrification); 2. Mid-term (<10 years) realistic target for efficiencies.  
Source: A.T. Kearney Energy Transition Institute analysis.

# Heat recycling is essential to increase the energy efficiency of stationary fuel cells and H<sub>2</sub> turbine plants

In a fuel cell or H<sub>2</sub> turbine, energy losses occur almost entirely in the form of heat. Heat losses can be recycled in two ways:

**For district heating purposes, if demand exists nearby.** Low-temperature heat is very difficult to transport over long distances. Combining electricity production with district heating creates a **combined heat and power system** [CHP]. Both low- and high-temperature fuel cells are suitable for CHP. Heat demand and electricity demand will rarely match up for a CHP plant. So operation will need to have either a heat-driven or electricity-driven profile. Historically, CHP was developed to improve the efficiency of large-scale centralized systems. However, with the low-temperature heat available from fuel cells, decentralized, residential micro CHP fuel-cell systems are an important part of today's fuel-cell system installations.

**Converted into electricity in a steam turbine.** Combining a fuel cell or combustion-turbine power plant with a steam turbine creates a **combined-cycle power plant**. These facilities require higher-grade heat exhausts (temperatures above 500°C) to drive the steam turbine with sufficient efficiency. They also need to be large systems because scaling up steam turbines generates important economic and efficiency benefits. Large-scale, high-temperature fuel cells or H<sub>2</sub> turbines would be suitable candidates for combined-cycle units. The main advantage of co-generation is the increased fuel-to-electricity efficiency at constant load. The main drawback is the lack of flexibility: the steam turbine can only be activated when the nominal load is maintained for several hours.

**Combined-cycle and CHP could be combined** (figure 92) and there are no technical barriers to applying these technologies to hydrogen fuel cells or turbines. The fuel-cell stack constitutes only a small part of the plant, in terms both of cost and size.

Figure 92: Example of a solid oxide fuel cell plant with CHP and combined-cycle

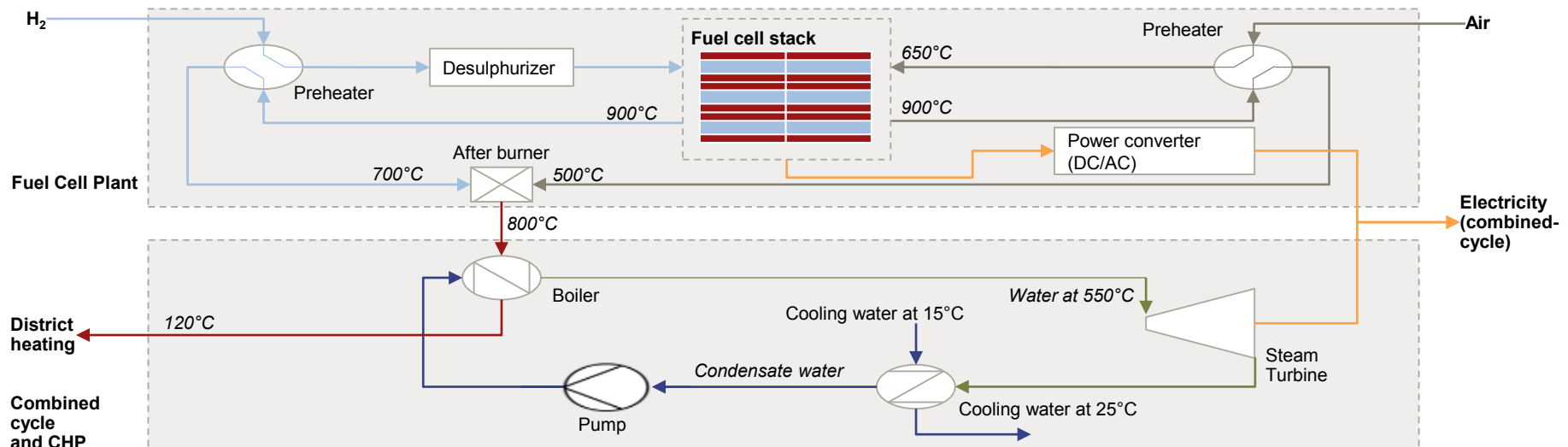

## Fuel cells have long been under development, but are only now starting to be commercialized

The principle of the fuel cell was discovered in the early 19<sup>th</sup> Century by German scientist Christian Friedrich Schönbein, while the first working fuel cell was developed by William Grove in 1839. However, the technology wasn't put to use until the mid-20th century, when NASA scientists started taking an interest in fuel cells to provide electrical power and potable water for manned space missions. That resulted in the development of the proton exchange membrane [PEM] and alkaline fuel cells.

In the 1970s, as environmental awareness rose and concerns over the availability of oil grew, fuel cells were developed for mobility. The first fuel-cell electric vehicles were built by German, Japanese and US vehicle manufacturers. At this time, Prof. John Bockris coined the term hydrogen economy in a speech at General Motors. Also in the 1970s, research into stationary applications became popular, ultimately resulting in the first large-scale demonstration of the phosphoric acid fuel cell [PAFC]. Research into stationary and mobile applications of fuel cells continued in the 1980s, leading to improved PAFC system efficiency and membrane durability. In the 1990s, attention turned to small stationary applications and PEM and solid oxide fuel cells, with the first micro-combined heat and power [CHP] plants being developed in Japan, Germany and the UK. However, throughout this whole period, hydrogen technology struggled to translate promise into commercial deployment.

Interest in fuel cells then dwindled, before growing again in the 2000s, as concerns grew over climate change, zero-emissions vehicles and supply security. This led to strong support from Asian, European and North American governments for research into cost and efficiency, and for demonstration programs (e.g. President G.W. Bush's \$1.2 billion plan for hydrogen). With the exception of a major CHP program in Japan, efforts focused once again on mobility and portable or small-scale niche applications (e.g. military, leisure, auxiliary power). **Despite this, fuel cell development lost momentum at the end of the last decade** in the face of high costs, the global economic crisis and the shale revolution, which diminished fears in the US regarding oil and gas prices and security of energy supply.

Now, however, fuel cells appear to be making a comeback, driven this time by the supply-side, i.e. an unexpectedly rapid development of intermittent renewable technologies and the falling costs of onshore wind and solar photovoltaic.

Figure 93: Timeline for the development of fuel cells

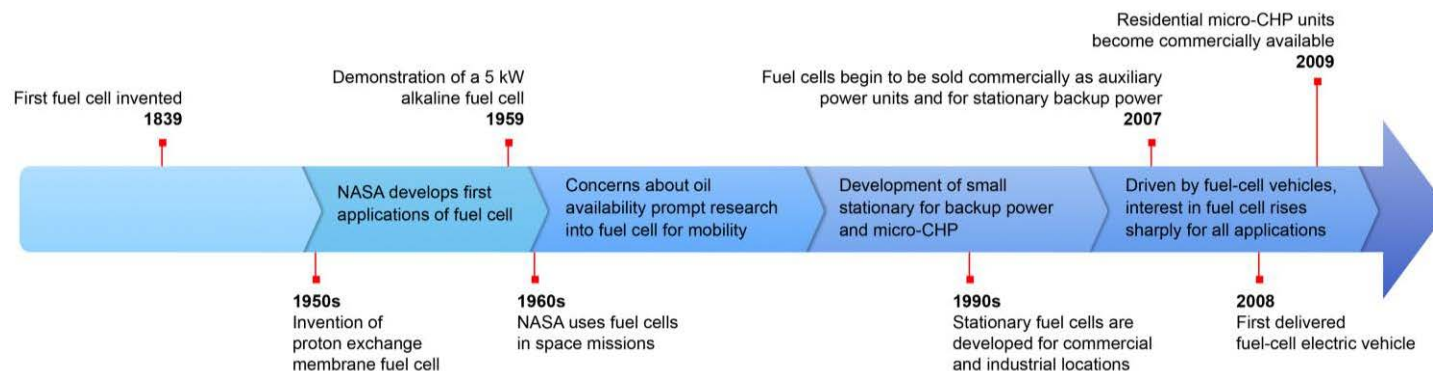

## Installed fuel-cell capacity has increased sharply in the past few years, increasingly led by stationary applications for back-up power systems

By end-2012, 505 MW of fuel cells had been sold commercially, of which 55% were for stationary re-electrification systems and 45% for fuel-cell electric vehicles (figure 94). A further 215 MW of capacity was forecast to be installed in 2013, with the share of stationary applications set to increase. In addition, 60 stationary demonstration projects totaling 1.6 GW were being planned: the average size of these demonstrator plants (27 MW) is very large for a fuel-cell system. The average size of individual fuel cell stacks sold so far is just 5 kW per stack on average.

Proton exchange membrane [PEM] technology has dominated sales in terms of capacity so far, due to its use both in stationary and mobility applications (figure 95). But, due to the much larger capacity of molten carbonate and solid oxide stacks used exclusively for stationary purposes, PEM has been overtaken in 2013. However, only a tiny proportion of these fuel cell plants (2.5 MW) use hydrogen sourced exclusively from electricity (see Section 2.8).

**Ambitious funding programs for fuel cells have been launched.** The US Department of Energy [DoE] has invested around \$100 million over the past four years. The objective was to accelerate fuel cell commercialization and deployment, and to support the immediate deployment of up to 1,000 fuel-cell systems in emergency back-up power, material handling, and CHP applications. In Europe, the Fuel Cell and Hydrogen Joint Undertaking [FCH JU] – a public-private partnership – coordinates funding for R,D&D in the hydrogen and fuel cell sectors. Its annual budget was €109 million in 2011, with 13% allocated to stationary fuel cells and CHP units. Of this share, 73% was allocated to R&D, 7% to demonstrations and 20% to market support. National funding schemes are complementing the EU scheme. Germany's National Hydrogen and Fuel Cell Technology Innovation Program is unique in its breadth: €1.4 billion will be invested over the 10-year period ending in 2016<sup>1</sup>. Finally, Asia now dominates the fuel-cell market (figure 96), following the launch in South Korea and Japan of ambitious hydrogen programs. In 2012, Japan invested almost \$240 million, nearly twice as much as the U.S. DoE. Half of Japan's investment took the form of subsidies for residential micro-CHP systems.

**Figure 94: Annual sales of fuel cells by usage**  
MW

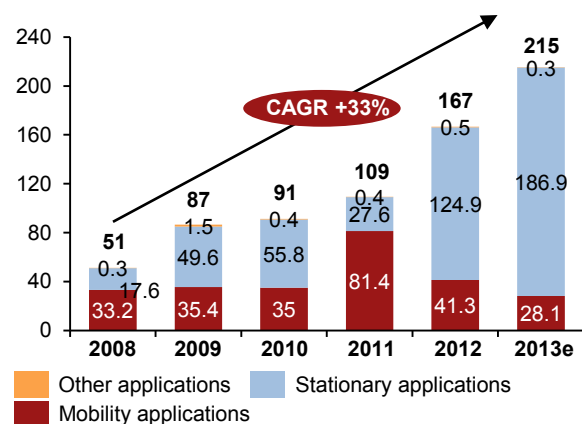

**Figure 95: Annual sales of fuel cells by type**  
MW

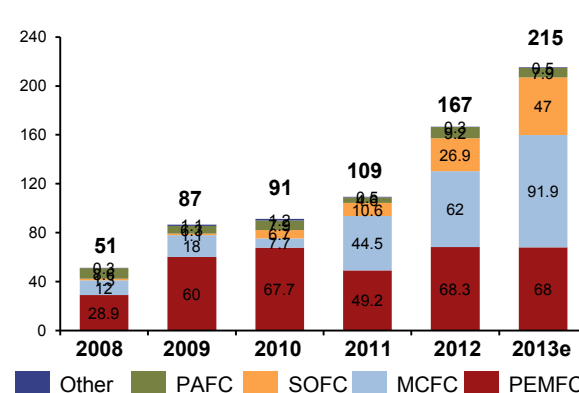

**Figure 96: Annual sales of fuel cells by region**  
MW

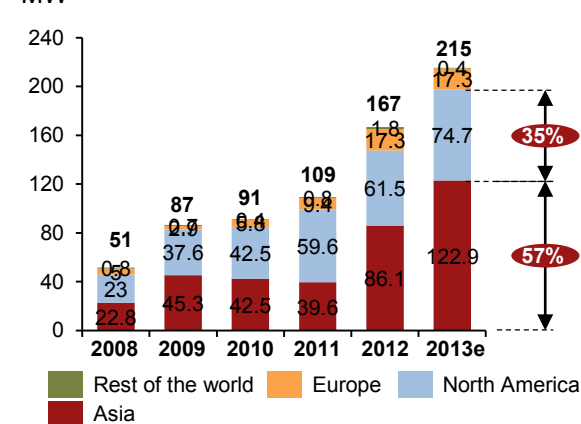

Note: Half of the €1.4 billion is supposed to be provided by industry participants.  
Source: FuelCellToday (2013).

# Fuel cells convert hydrogen and oxygen into electricity and water, acting, in theory, as an electrolyzer operated in reverse mode

A **hydrogen fuel cell** is a converter that generates electricity and water by combining a hydrogen-rich fuel with an oxidizing agent, usually oxygen. The overall reaction is exothermic and can be chemically expressed with the equation  $2\text{H}_2 + \text{O}_2 \rightarrow 2\text{H}_2\text{O} + \text{energy}$ , comprised of heat and an electric current.

Similarly to electrolyzers, fuel cells consist of a stack of individual cells that are each composed of two electrodes, an electrolyte solution and a catalyst (figure 97). The reaction that produces electricity occurs at the electrodes: hydrogen is injected into the anode, and oxygen is injected into the cathode. The solid or liquid electrolyte solution enables a reaction by filtering the ions that can pass through it. A catalyst is used to accelerate the reaction. Unlike batteries, whose energy production is limited by the amount of potential energy stored, fuel cells rely on an external source of energy and therefore operate as long as they are supplied with energy.

A fuel-cell [FC] system is generally referred to as an FC battery for mobile systems, or an FC plant for a stationary system (figure 98). The following section focuses mainly on stationary systems. An FC plant consists of fuel cells stacks connected in series, plus a balance of plant consisting of pumps, compressors, power converters, cooling circuits and other small components.

Fuel-cell type refers to the technology used for the cell, differentiated by the chemical composition of the electrolyte and grouped according to their operating temperature: proton exchange membrane and alkaline FCs are low-temperature fuel cells. Phosphoric acid, molten carbonate and solid oxide are high-temperature fuel cells (see following slides).

Figure 97: Schematic diagram of a proton exchange membrane fuel cell

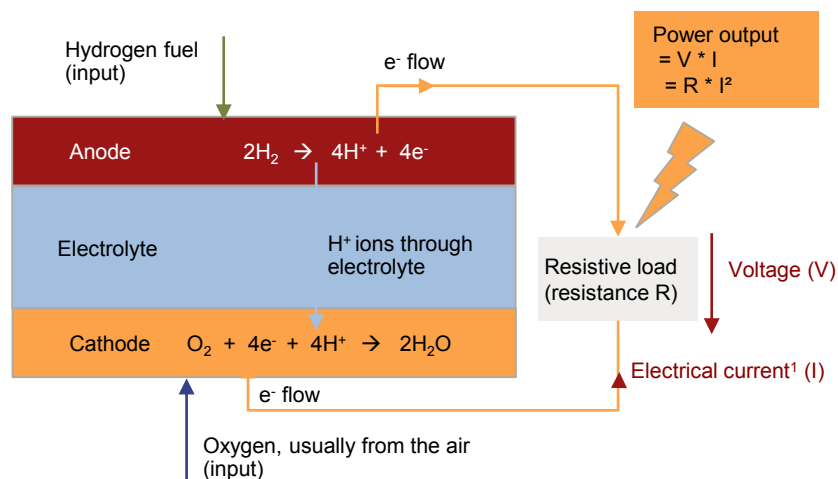

1. The electrical current is proportional to the flow of electron per second, but in the opposite direction because electrons have negative charge; 2. Some components may be omitted.

Source: A.T. Kearney Energy Transition Institute analysis.

Figure 98: Schematic of a fuel cell plant<sup>2</sup>

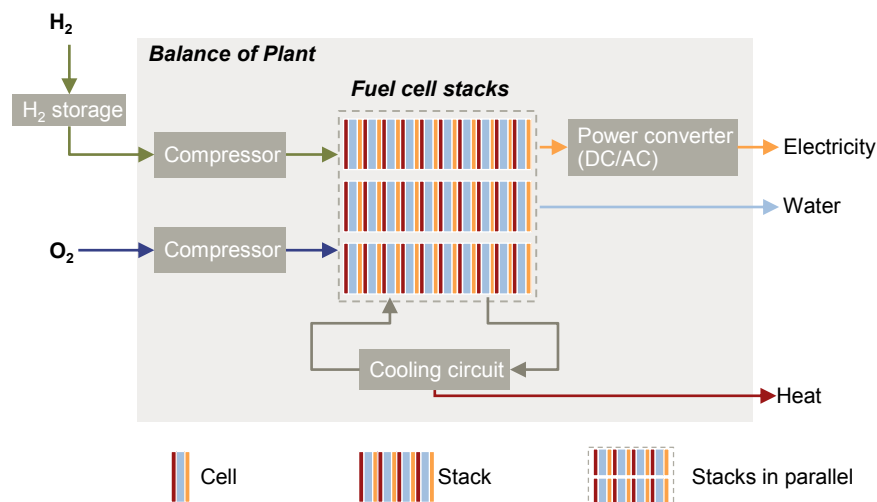

# The hydrogen-to-electricity efficiency of a given fuel cell decreases with its power output

The energy input of a fuel cell is the chemical energy of hydrogen, measured in  $\text{Wh}_{\text{ch}}$ . **The fuel-cell's output energy, delivered per unit of time, is the electric power applied to the load, defined as the product of the electrical current (I) supplied, measured in amperes (A), and the operating voltage of the fuel cell, measured in volts (V).** The hydrogen-to-electron reaction rate that takes place at the surface of the electrodes is controlled by (i) the surface of the electrode area, (ii) the type of catalyst coated on the electrode's surface, and (iii) the operating temperature and pressure.

- **Current (I)** is the variable controlled by demand from the power grid connected to the fuel cell. Because it is directly proportional to the hydrogen reaction rate, the fuel-cell operator needs to adapt the input flow rate of hydrogen. The power output of the fuel cell can be increased up to, but not above, its rated capacity. **Current density (i)**, in  $\text{mA}/\text{cm}^2$ , is generally used to normalize the current per surface of electrode area. The role of catalysts is to increase this hydrogen reaction rate per surface area, or current density.
- **Operating voltage (V)** is a variable resulting from current density, and is not directly controllable by the operator. For a given fuel cell, voltage is a decreasing function of current density (continuous line, figure 99). The curve shape depends on the fuel-cell type (see next slide), but, in general, voltage drops significantly above a certain current-density threshold ( $810 \text{ mA}/\text{cm}^2$  in this example).
- Consequently, the resulting cell output power ( $I \cdot V$ ) reaches a maximum value for a current density that will define the nominal operating mode of the fuel cell (red line). Any increase in current density beyond this value would be sub-optimal: the same output could be reached with lower current density and higher efficiency.

So, **when operating a plant, a fuel-cell operator must make a trade-off between electrical power output (or power density) and energy efficiency.** The highest efficiency is reached at minimal load. Increasing the load up to 100% (nominal) comes at the expense of efficiency.

**Figure 99: Typical fuel cell current density, operating voltage, efficiency and power density curve**

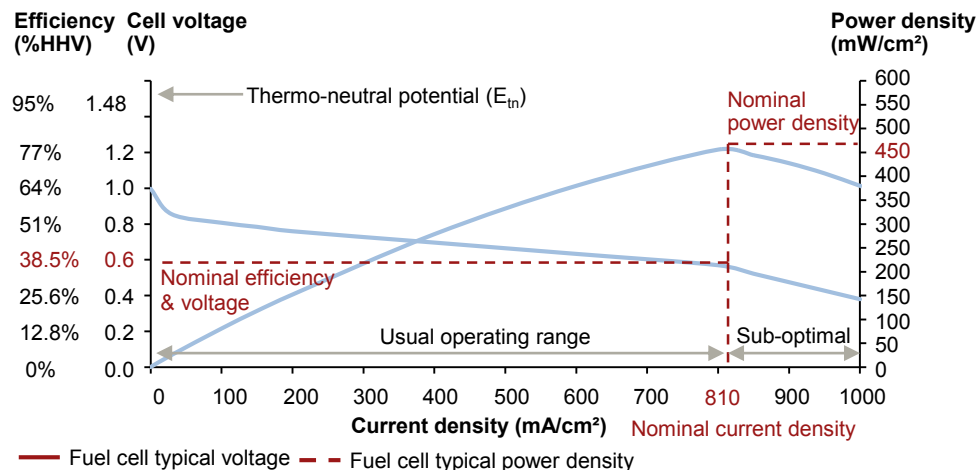

**Fuel Cell Efficiency ( $\eta$ )** equal  $\frac{V \cdot i}{\text{H}_2 \text{ energy flow}}$ . The efficiency is proportional to the voltage  $V$ , but is always lower than 100%. In theory, 100% efficiency is achievable when  $V=1.48\text{V}$ , referred to as **thermo-neutral potential ( $E_{\text{in}}$ )**, and  $\eta(\text{theoric}) = \frac{V}{1.48}$ .

In practice, due to engineering issues, there is always a small fraction of hydrogen that come out unreacted from the electrodes, estimated at about 5%, so that  $\eta = 0.95 \cdot \frac{V}{1.48}$ .

Finally, during operation ( $i>0$ ), the movement of electrons ( $e^-$ ) and protons ( $\text{H}^+$ ) creates heat energy losses by resistive (Joule) effect, which reduces energy efficiency by lowering  $V$  well below  $E_{\text{in}}$ . These resistive losses increase with current density ( $i$ ), which explains why  $V$  and  $\eta$  are decreasing function of  $i$ . In the example,  $V = 40\% E_{\text{in}}$  at nominal load, so that  $\eta = 38.5\%$

## Fuel cells designed to operate at higher pressures and/or temperatures are generally more efficient

All other things being equal, fuel cells able to operate at higher current densities are cheaper to manufacture per kW, as cell surface area is smaller for the same nominal output capacity. But, in practice, the build of components means high current densities also put more stress on the cells, and necessitate more expensive materials to avoid losses in nominal performance.

The **operating temperature** of a fuel cell is defined by the choice of cell design and component (usually the electrolyte), and is not at the discretion of the plant operator. As shown in figure 100, at any given current density, high-temperature fuel cells have a higher operating voltage, and consequently are more efficient than low-temperature ones. In other words, the same efficiency can be reached at a higher current density and thus at a lower cost per kW. As a result, high-temperature cells are better suited to combined heat and power generation.

The **pressure of the system** is the only externally controllable factor that can increase system performance. As shown in figure 101, for the same current density, the operating voltage rises with pressure, increasing power supplied to the load and cell efficiency. But pressurizing involves costs, weight and the space occupied by the compression equipment, plus additional costs to enable the fuel cell components to withstand higher pressures. Thus, the range of pressures and temperatures under which a fuel cell can operate are largely constrained by the manufacturer's specifications.

So, there is a small margin for maneuver in the operation of an installed fuel cell. Most parameters (temperature, nominal current density and accessible pressures) are set by the manufacturer's specifications. The **H<sub>2</sub>-consumption rate is not dictated by the amount supplied to the cell**: the operator will mostly modulate the fuel-cell load (power output) by varying current density, which is achieved by modulating the resistance of the downstream electric circuit connected to the fuel cell. The H<sub>2</sub>-consumption rate will follow the load. Finally, efficiency is improved when operating at reduced load.

**Figure 100: Fuel cell efficiency, operating voltage and power density according to the temperature, for different current densities (illustrative)**

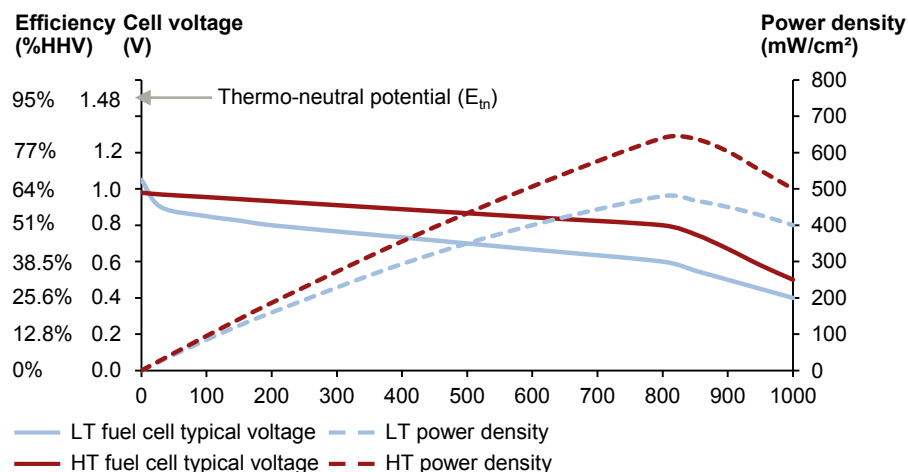

Source: A.T. Kearney Energy Transition Institute analysis, based on Larminie et al. (2003).

**Figure 101: Difference in the fuel cell operating voltage at different pressures (illustrative)**

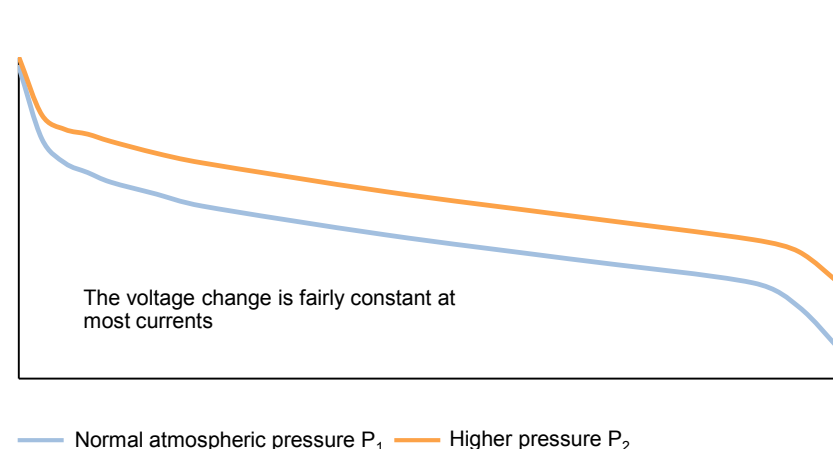

## 5 different type of fuel cells have been developed, grouped between low and high temperature

**Fuel cells are mainly distinguished by the composition of their electrolytes**, which determines the operating temperature, the chemical reactions that occur within the cell and the type of fuel that can be used as feedstock. Fuel cell parameters, such as maximum efficiency and power density, are also a function of temperature. Fuel cells are therefore usually categorized into two groups: low-temperature and high-temperature fuel cells.

**As with electrolysis, low-temperature fuel cells include alkaline fuel cells [AFC] and proton exchange membrane fuel cells [PEMFC]<sup>1</sup>.** These are simple and quick to start up, making them well suited to smaller systems, as they avoid the safety and maintenance issues usually resulting from high operating temperatures. AFCs and PEMFCs compete for the same applications. AFCs have been used since the 1960s in many applications, including NASA space missions, but most research and industry initiatives now focus on PEMFCs, which are considered more promising.

**High-temperature fuel cells include phosphoric acid fuel cells [PAFC], molten carbonate fuel cells [MCFC] and solid oxide fuel cells [SOFC].** Due to their higher operating temperature, these fuel cells can achieve higher efficiencies, are more suited to combined heat and power [CHP] applications and can be fuelled with methane rather than pure hydrogen. They are technologically less mature than their low-temperature counterparts, but are starting to be commercialized for stationary back-up power applications, mostly fuelled by natural gas. Among high-temperature fuel cells, the least mature SOFCs are expected to achieve the highest efficiencies and benefit from greater cost reductions in the future.

**Figure 102: Comparison of hydrogen storage characteristics**

Group	Fuel cell type	Electrolyte	Operating temperature	Investment cost (cells & stacks)	Typical stack size	Efficiency: fuel to electricity <sup>3</sup>	Efficiency: combined heat and power <sup>2</sup>	Lifetime
Low temperature	Proton exchange membrane [PEMFC] <sup>2</sup>	Perfluoro sulfonic acid polymer	-20-100°C	< \$3,200 /kW for CHP	1-250 kW	32%	72%	10,000 hours (stationary)
	Alkaline [AFC]	30-45% KOH aqueous solution	25-250°C	\$200-700 /kW	10-100 kW	50%	N/A	5,000-8,000 hours
High temperature	Phosphoric acid [PAFC]	≈ 100% pure phosphoric acid	150-200°C	\$2,270-4540 /kW	0.05-1 MW	30-45%	72%	15,000-20,000 hours
	Molten carbonate [MCFC]	$\text{Li}_{0.62}\text{K}_{0.38}\text{CO}_3$ $\text{Li}_{0.62}\text{Na}_{0.5}\text{CO}_3$	600-700°C	\$4,200 /kW	0.01-5 MW	42-48%	72%	20,000-30,000 hours
	Solid oxide [SOFC]	Yttria-stabilized zirconia	600-1000°C	< \$3,200 /kW for CHP	0.001-3 MW	50%	72-76%	15,000 hours (CHP system)

1. Note that PEMFC efficiency may be minimized compared to alternative fuel cell whose efficiency is derived from use with natural gas feedstock; 2. For stationary applications; 3. Efficiency figures are in HHV.

2. Source: A.T. Kearney Energy Transition Institute analysis; US DoE (2011); Cerri et al. (2012).

# Although proton exchange membrane fuel cells were first developed for the automotive industry, they are also fit for stationary applications

## Status and outlook

Proton exchange membranes [PEM] have been developed for fuel-cell-electric vehicles in the past 20 years because they are very compact, have no moving parts and can be used in any orientation. They benefit from very high flexibility and fast responsiveness, making them ideal for variable generation. This means they are used increasingly for stationary applications, mainly back-up power units and micro combined heat and power for residential applications.

PEM fuel cells suffer from a low fuel-to-electricity efficiency (figure 104) and, like PEM electrolyzers, are still limited to small-scale applications.

Today's research focuses on water management, overcoming electrode corrosion, reducing the content of noble materials used as catalysts, operating at higher temperatures for higher efficiencies and demonstrating the cell's ability to serve megawatt-scale applications.

## Comparative advantages

- Flexible (in load amplitude)
- Reactive (in load ramping rate)
- Immediate cold start (from prolonged shut down)
- Solid electrolyte allows utilization in any orientation
- Low scaling effect (small systems as efficient/cheap as larger ones)

## Comparative drawbacks

- Low efficiency
- Up-scaling unproven
- Costly platinum catalyst
- Low temperature heat losses unsuitable for large-scale CHP
- Sensitive to fuel input impurities
- Water management

**Figure 103: Schematic of a PEMFC (left)<sup>1</sup> and stack interconnection (right)<sup>2</sup>**

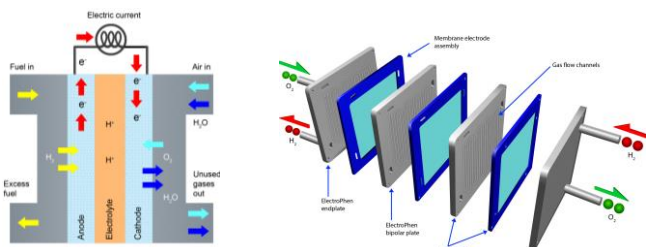

Hydrogen is channeled through field flow plates to the anode, while oxygen is similarly channeled to the cathode. The platinum catalyst (bipolar plate) causes hydrogen to split into hydrogen ions and electrons. The membrane acts as an electrolyte and only lets H<sup>+</sup> ions flow through it to the cathode. The electrons must travel through an external circuit to the cathode, creating a current. At the cathode, electrons and hydrogen react with oxygen to produce water. The assembled anode-membrane-cathode is very thin and cell stacks are connected in series, which makes water management quite a challenge.

**Figure 104: Key figures for stationary PEMFC system**

Maturity	Commercial
Maximum current density	1.5 A/cm <sup>2</sup>
Operating pressure	1-5 bar
Operating temperature	-20 – +100 °C
Flexibility (minimal load)	unknown
Reactivity and cold start	Excellent
Fuel to electricity efficiency (HHV)	32% (state of the art) 40-50% (2020-2030) <sup>1</sup>
CHP efficiency (HHV)	72% (state of the art) 76% (2020-2030)
Typical stack size	1-250 kW
Investment costs	< \$3,200 /kW (state of the art – CHP) < \$800 /kW (2020-2030)
Lifetime	10,000 h (state of the art) 50,000 h (2020-2030)

1. Note that PEMFC performance may be minimized compared to alternative fuel cell whose efficiency is derived from use with natural gas feedstock  
Source: Image courtesy of: 1. NARED, 2. Bac2; Larminie et al. (2003); Cerri et al. (2012), US DoE (2011).

# High efficiency of solid oxide fuel cells makes them the best option for stationary CHP generation

## Status and outlook

Solid oxide fuel cells [SOFC] (figures 105 and 106) operate at high temperatures, improving fuel-to-electricity efficiency. The high operating temperature also improves the kinetics of the reaction, avoiding the need for a metal catalyst. However, it also results in longer start-up time, requires more robust heat-resistant materials and must be designed to prevent heat losses.

SOFCs accept not only H<sub>2</sub>, but also any light hydrocarbon (e.g. methane, propane) or CO as input fuel. Methanol fuel cells are also being developed.

Due to their technical features, SOFCs are mainly appropriate for large-scale stationary applications that are infrequently started up and shut down, or for decentralized combined heat and power [CHP] plants.

R&D is focusing on developing new materials that could increase the lifetime of the cells, new modular and stacking concepts to reduce costs, and on demonstrating the potential of SOFCs for large-scale applications.

## Comparative advantages

- Highest efficiency among fuel cells
- Suitable for CHP and combined-cycle
- No noble metal catalyst for large cost-reduction potential
- Fuel flexibility (methane or methanol can be used instead of hydrogen)
- Good tolerance to fuel impurities
- Simple system with only two phases (gas and solid)
- Easily reversible into electrolyzer

## Comparative drawbacks

- Technical maturity
- Current manufacturing costs
- Limited material lifetime at the moment
- Cold start takes several hours
- Load flexibility while in operation too limited for highly variable production

**Figure 105: Schematic of SOFC cell (left) and stack (right)<sup>1</sup>**

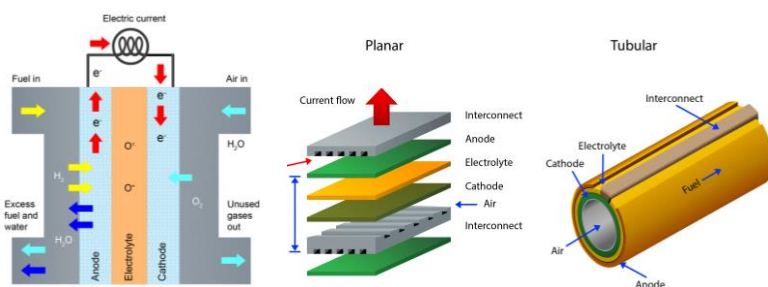

All components of the solid oxide cell (anode, cathode, electrolyte) are in solid phase and the water produced is gaseous, so management of any liquid phase is avoided. The charge carrier flowing through the cell is O<sup>2-</sup>, which has two negative charges per molecule, allowing for higher current densities. Stack arrangement can be planar or tubular. The high temperature at the anode will transform any light hydrocarbon into H<sub>2</sub> and CO by internal reforming, prior to their electrochemical conversion into water and CO<sub>2</sub>, respectively.

**Figure 106: Key figures for a SOFC with CHP system**

Maturity	Demonstration / Early deployment
Maximum current density	N/A
Operating pressure	1 bar, 4 bar (potentially)
Operating temperature	800-950°C
Flexibility (min load)	unknown
Cold start duration time	5 – 12 h
Fuel to electricity efficiency (HHV)	50%
CHP efficiency (HHV)	72 – 76% (state of the art) 76 – 80% (2020 – 2030)
Max stack size	1 kW – 3 MW
Investment costs in CHP	< \$3,200 /kW (today); \$800 /kW (2020 – 2030)
Lifetime	15,000 h (state of the art) 50,000 h (2020 – 2030)

## Gas turbines could be a good alternative to fuel cells for large-scale stationary applications

Turbines are a commercially mature technology for power generation from natural gas. The same principle could be used to produce electricity from hydrogen, which behaves like a gaseous fuel (figure 107). Hydrogen and oxygen are combusted in a burner, producing hot, pressurized water vapor that then drives a turbine. The mechanical energy produced by the turbine is turned into electricity by a generator.

A pure hydrogen turbine would have a slightly different design from that of a natural gas turbine because of the different ways the two fuels behave when combusted with oxygen<sup>1</sup> (see next slide). However, the balance of plant would be similar (boilers, compressors, pumps, cooling systems etc.). This means little technical modification would be needed to operate gas turbines using either methane or hydrogen, or mixtures such as hydrogen-enriched natural gas [HENG] ( $\text{CH}_4 + \text{H}_2$ ), or syngas<sup>2</sup> ( $\text{H}_2 + \text{CO}$ ). In fact, **flexible-fuel turbines have already been commercialized for use in coal-gasification power plants, where hydrogen content input can vary up to 50% in mass<sup>3</sup>**. Turbines powered by pure hydrogen remain in the early demonstration phase because of limited demand.

So, electrolytic hydrogen could be used today as a fuel-enricher for both natural gas and syngas turbines. Hydrogen actually slightly improves the performance of gas turbines, raising their energy efficiency and reducing their  $\text{CO}_2$  emissions. But some adverse impacts have also been observed, which need attention, including an increase in the burning velocity, an extension of flammability limits (resulting in a lower ignition temperature) and an increase in  $\text{NO}_x$  emissions.

In contrast to fuel-cell plants made of multiple stacks of fixed size operating in parallel, economies of scale are more evident in the cost of a turbine, as commercial plants must be at least 50 MW. The efficiency of flexible gas turbines is about 40% in open cycle, which is close to that of low-temperature fuel cells. However, gas turbines are good candidates for combined-cycle plants, permitting very high efficiency conversion (60%) in continuous operation.

Figure 107: Schematic of a hydrogen turbine (left)<sup>4</sup> and illustration of a hydrogen turbine (right)<sup>5</sup>

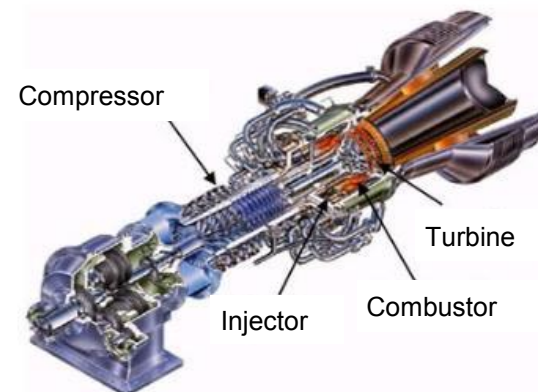
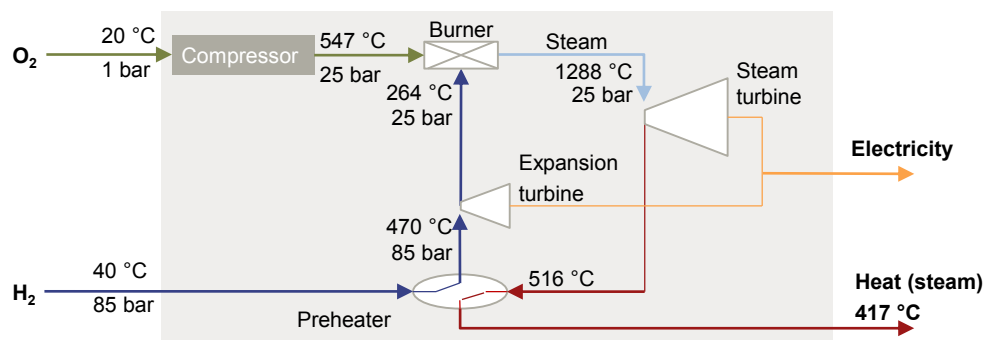

1. Combustion Heat, flame velocity summarized by the Wobbe Index (Section 2.4); 2. Syngas = synthesis gas. Source: 3. GE (2010); 4Steward et al. (2009), image courtesy of: 5Siemens (2007).

# Pure hydrogen turbines pose few technical challenges, but are of limited interest at the moment, especially for electrolytic hydrogen production

## Status and outlook

Pure hydrogen turbines are still at the demonstration stage. Interest in them is being driven by their role in carbon capture and storage [CCS] projects rather than their use in electrolytic systems. The first pilot plant running on 100% hydrogen feedstock is the 16 MW Enel plant in Fusina, Italy, which has an electrical efficiency of 41.6% (figure 108). The turbine is part of a CCS demonstration plant where the hydrogen is sourced from coal gasification through pre-combustion capture.

A pure hydrogen turbine it is not considered technically problematic, but developers are focused more on improving the flexibility of gas turbines so they can better accommodate a variable mix of fuels (hydrogen, CH<sub>4</sub>, syngas).

**Figure 108: Enel's Fusina hydrogen pilot power plant**

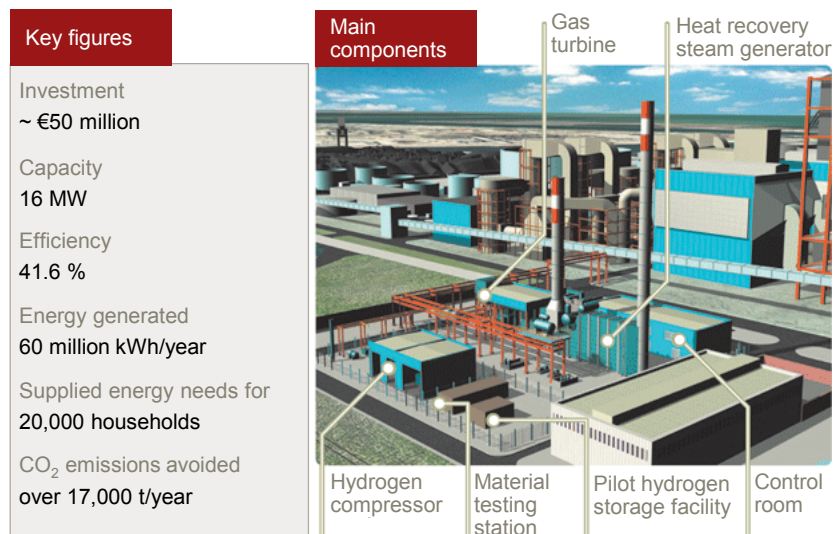

## Comparative advantages of H<sub>2</sub> turbines

- Near-zero greenhouse gas emissions
- Higher efficiencies than conventional gas turbines
- Higher efficiencies than fuel cells in combined cycle
- Lower capital costs than fuel cells
- Benefits from R&D in pre-combustion CCS power plants

## Comparative drawbacks of H<sub>2</sub> turbines

- Strong cost-scaling effect a limitation on decentralized applications
- Electrolyzer plant size unlikely to match that of H<sub>2</sub> turbines in the short term

Maturity	Demonstration at pilot-scale
Power	1-300 MW
Investment cost	\$3,125 /kW in Fusina; \$1,000 /kW (expected);
O&M cost (system)	\$0.008 /kW/year
Lifetime	20 years
Electrical efficiency (HHV)	< 45% in open cycle < 60% in combined cycle
Ramp-up rate	Excellent from hot start <sup>1</sup>
R&D axis	<ul style="list-style-type: none"> <li>• Materials capable of resisting high temperatures</li> <li>• Better turbine aerodynamics</li> <li>• Improved fuel flexibility – operate with NG, Syngas and H<sub>2</sub>;</li> <li>• Increase exhaust temperature to maximize combined cycle;</li> <li>• Reduce NO<sub>x</sub> emissions at higher temperatures;</li> <li>• Better control of combustion dynamics and flame speed;</li> <li>• Reduce cooling system and leakage problems;</li> </ul>

## Sources: section 2.3

- Ball et al. (2009), *"The Hydrogen Economy – Opportunities and Challenges"*, Michael Ball, Martin Wietschel, Cambridge University Press
- Cerri et al. (2012), *"Scientific assessment in support of the materials roadmap"*, Isota Cerri, Florence Lefebvre-Joud, Peter Holtappels
- Enel (2008), *"At Fusina, inauguration of site for first industrial-scale hydrogen plant in the world"*
- FuelCellToday (2012), *"The Fuel Cell Industry Review 2012"*
- Fuel Cells and Hydrogen Joint Undertaking – FCHJU 2011, *"Program Review 2011"*
- GE (2010), *"Syngas Turbine Technology"*, [http://www.ge-energy.com/content/multimedia/\\_files/downloads/Syngas%20Turbine%20Technology.pdf](http://www.ge-energy.com/content/multimedia/_files/downloads/Syngas%20Turbine%20Technology.pdf)
- Larminie et al. (2003), *"Fuel cell systems explained"*, James Larminie, Andrew Dicks, Wiley
- New Energy World Industry Grouping – NEW IG (2011), *"Fuel Cell and Hydrogen technologies in Europe: financial and technology outlook on the European sector ambition 2014 – 2020"*
- Pilavachi et al. (2009), *"Multi-criteria evaluation of hydrogen and natural gas fuelled power plant technologies"*, Petros A. Pilavachi, Stilianos D. Stephanidis, Vasilios A. Pappas, Naim H. Afgan, Applied Thermal Engineering, vol. 29, pp. 2228-2234
- Siemens (2010), *"Advanced hydrogen turbine development"*, Joseph Fadok, presentation at UTSR workshop
- Steward et al. (2009), *"Lifecycle cost analysis of hydrogen versus other storage options"*, National Renewable Energy Laboratory
- United States Department of Energy – US DoE, The Hydrogen Analysis (H2A) Project, Hydrogen and Fuel Cell Program, [http://www.hydrogen.energy.gov/h2a\\_analysis.html#h2a\\_project](http://www.hydrogen.energy.gov/h2a_analysis.html#h2a_project)
- Wallner et al. (2007), *"The effects of blending hydrogen with methane on engine operation, efficiency, and emissions"*, Thomas Wallner, Henry K. Ng, Robert W. Peters, Technical Papers presented at SAE World Congress & Exhibition

## 2.4 - Hydrogen-to-gas: blending with natural gas & methanation



## Summary & key findings: section 2.4

1. **Power-to-gas [P2G]** projects transform electricity into hydrogen gas, which can be carried in an existing natural gas grid, allowing its calorific value to be monetized. Because H<sub>2</sub> can be transported through gas infrastructure, P2G may help to decompartmentalize the two main energy grids of industrialized countries, offering three benefits: (1) a one-way storage system for the electricity grid – P2G alone cannot re-inject stored electricity; (2) the freeing-up of electricity-grid infrastructure, which generally has smaller capacity than natural gas capacity; (3) Reduced demand for natural gas imports and partial decarbonization of the natural gas grid. P2G is in its early demonstration phase, although the technologies have been known for a century. With ~2.4 MW of capacity installed and ~9.1 MW planned, it accounts for most of the planned integrated electrolytic hydrogen projects.
2. **The chemical energy of H<sub>2</sub> can be transported through the gas grid in two ways: partially blended with natural gas; or after being converted into synthetic methane.** Although the economics of P2G projects are not yet proved, it already seems clear that neither separating back H<sub>2</sub> from hydrogen-enriched natural gas [HENG] nor methane reforming make sense economically: P2G should not be seen as mere H<sub>2</sub> transport option.
3. **H<sub>2</sub> blending** is a low-cost, early stage solution for monetizing electricity surpluses in countries with a highly developed natural-gas infrastructure. The additional costs of injection facilities are minimal, and pure-hydrogen storage could be reduced to small buffer tanks. The maximum blending ratio tolerated by existing, unmodified gas infrastructure remains difficult to assess precisely, and is determined by pipeline integrity and safety issues, hydraulic constraints on grid transport capacity, and, most importantly, by the sensitivity of end-use appliances to hydrogen/methane blends. Legislation for HENG remains sparse in most countries. In general, the entire gas grid should tolerate 5% volume blending anywhere, and up to 20% in distribution or regional transport pipelines with no critical downstream appliances. More R&D is needed to refine authorized blending limits:
  - If hydrogen is directly injected into a distribution or regional transport pipeline, assuming 20% blending is authorized, maximum achievable, annual H<sub>2</sub>-injection is limited by periods of low demand (summer in Europe). Additionally, operational upstream hydrogen-injection projects that are already injecting H<sub>2</sub> into the grid will diminish the H<sub>2</sub> injection potential of downstream projects. Consequently, the potential scale of each project is likely to remain limited; and
  - If H<sub>2</sub> is mixed directly into existing natural gas salt caverns, the blending ratio should be limited to 5%, because caverns are linked to the sensitive national grid. However, in countries with highly developed gas infrastructure, the sheer size of caverns offers great hydrogen storage potential, even at 5% volume.
4. **Methanation** incurs greater energy losses (more than 23%) and requires higher investment (around €700 /kW more in 2020) than blending, but the process allows full access to the gas grid and benefits from the higher volumetric density of methane compared with hydrogen. The siting of methanation plants is constrained by access to both a CO<sub>2</sub> source and existing natural gas infrastructure.
  - The best source for CO<sub>2</sub> is biomass-to-methane plants, because of biomass's higher carbon content relative to methane, and its renewable nature. Synergies between electrolysis, methanation and biomass digestion/gasification lead to around a 20% gain in biomass conversion efficiency and ~50% reduction in biomass feedstock requirements, easing competition for land use. In the future, power-to-methane projects may source CO<sub>2</sub> from oxy-combustion carbon-capture plants, instead of biomass, but this would require very large-scale installations;
  - There are two methanation processes: thermochemical and biological catalysis. The former is the pre-eminent technology at present. Invented by Paul Sabatier in 1897, it is well understood, but is still in the demonstration phase in P2G projects. Biological catalysis is an adaptation of the anaerobic-digestion process used in biogas plants. Applying this to P2G facilities is a relatively new concept and, as yet, undemonstrated. Both processes have advantages and drawbacks: the biological method seems better adapted to small-scale applications, and the thermochemical method to mid- to large-scale ones

# Power-to-gas may change the rules of the energy game by linking the natural gas grid with the power grid

**Power-to-gas [P2G] projects transform electricity into H<sub>2</sub>, which is transported in the natural-gas grid, delivered and consumed, monetizing its calorific value (figure 110). H<sub>2</sub>'s chemical energy can be transported in the gas grid in two ways:**

- **Blending:** H<sub>2</sub> is injected into gas pipelines, creating H<sub>2</sub>-enriched natural gas [HENG], an unreacted mixture of both gases. H<sub>2</sub> blending incurs negligible energy losses and requires little additional investment, but volumes are constrained by the limited concentration of H<sub>2</sub> that can be blended into the grid without the need for modifications; and
- **Methanation:** this process transforms H<sub>2</sub> and carbon dioxide [CO<sub>2</sub>] into methane [CH<sub>4</sub>], or synthetic natural gas [SNG]. Methane is denser and easier to transport than hydrogen, and requires no modifications to existing gas infrastructure. But methanation needs additional capital investments and incurs energy-conversion losses.

**P2G is the missing link between the two main energy carriers: the natural gas and electricity grids (figure 109).** Such a union of power- and gas-grid infrastructure may catalyze the development of a decarbonized energy industry. Its four main benefits are: (1) Provision of a one-way storage system for the electricity grid; unlike conventional storage systems, P2G cannot re-inject stored electricity unless specially configured to do so; (2) Providing additional energy-transport capacity to relieve electricity-grid infrastructure, which, generally, has less capacity and is more expensive than gas-grid capacity; (3) Accelerating the transition to an H<sub>2</sub> economy, by enabling supply to meet unlimited demand; and (4) The decarbonizing of natural gas networks and reducing the need for gas imports. **Methane is forecast to play an ever-larger role in future energy systems<sup>1</sup>:** global gas reserves are growing; its combustion is cleaner than other hydrocarbons, reducing local pollution; and gas-fired power plants provide valuable flexibility to the power grid.

**Figure 109: Pathways between energy carriers**  
Power-to-gas pathway in red

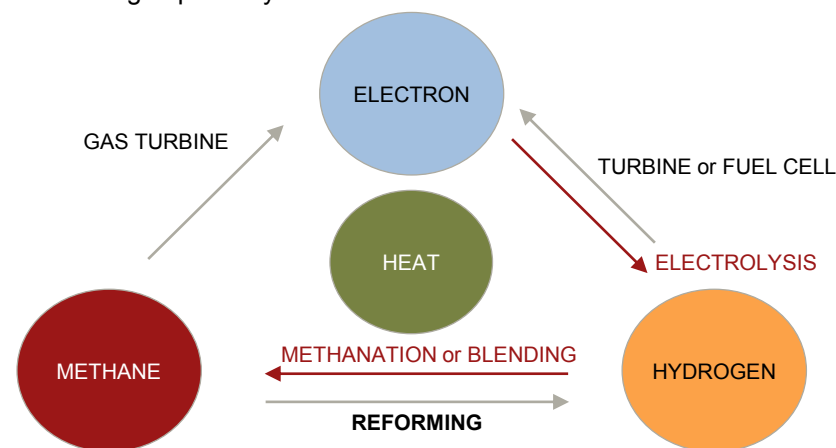

**Figure 110: Pathways between energy grids**

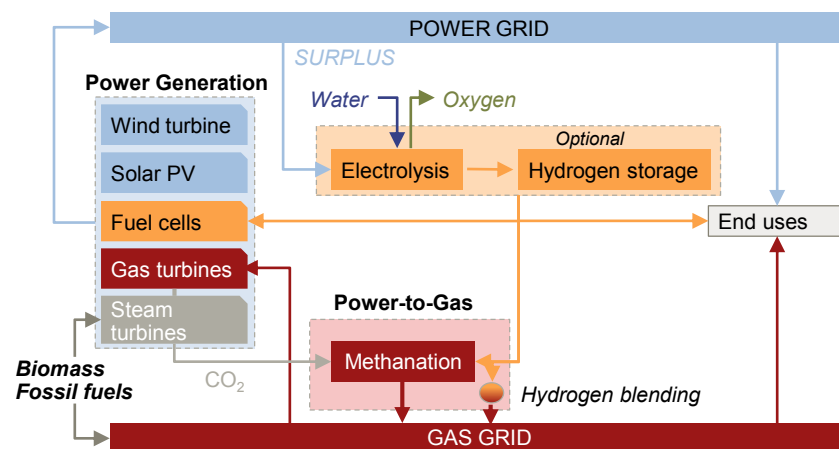

1. The International Energy Agency predicts the world will enter a golden age of gas. Source: A.T. Kearney Energy Transition Institute analysis.

## Germany is the global laboratory for power-to-gas projects

**Researchers at Kassel University, Germany, introduced the concept of power-to-gas [P2G] in 2009, although the technologies required to transform electricity into hydrogen or methane have been known for a century.** Germany's state-controlled energy agency set up the Power-to-Gas Strategy Platform to coordinate projects to enable the country's transition (*Energiewende*) to renewable energy sources. National Organization for Hydrogen and Fuel Cell Technology [NOW] was set up in 2008, with a 10-year budget of €1 billion. It allocates some of these public funds to selected P2G pilot projects through the National Innovation Program [NIP], a private-public partnership. Beyond Germany, DNV KEMA<sup>2</sup> has initiated the North Sea Power-to-Gas Platform, a grouping of 11 leading European companies, and is also looking to establish a Mediterranean P2G platform.

**Some integrated P2G demonstration projects are in the early demonstration phase (figure 111):**

- Two demonstration methanation pilot projects are operational, but are yet to inject SNG into the gas grid;
- Five MW-scale, pre-commercial projects, fully linking the power and gas grids are under construction in Germany (one of which involves methanation); and
- P2G is attracting interest in Denmark, Belgium, the Netherlands, Sweden, France and Canada, where pilot projects have been announced.

**P2G could be industrially feasible by 2015, with commercial deployment starting between 2015 and 2020, in regions with favorable conditions:** high penetration of intermittent energy sources in the power mix; well-developed natural gas or biogas infrastructure; and low pumped-storage hydro capacities.

**Figure 111: Integrated power-to-gas pilot projects passed final investment decision, as of November 2013<sup>1</sup>**

Project	Country	Status	Type	Project size	Injection in gas grid
NATURALHY	Europe	Operations ended in 2009	HENG feasibility study	N/A (€17 million)	No
Morbach	Germany	Operations ended in 2009	Methanation, CO <sub>2</sub> from biogas	25 kW	No
Etogas Alpha Plant	Germany	Operating ( since 2009)	Methanation, CO <sub>2</sub> from air	25 kW	No
Etogas & ZSW Stuttgart	Germany	Operating (since 2013)	Methanation	280 kW	No
Foulum project	Denmark	Operations to begin Q2 2013	Methanation (biological), CO <sub>2</sub> from biogas	250 kW	No
ITM Power Gridgas project	UK	Operation to begin in 2013	HENG feasibility study	0 kW (£164,000)	No
E.ON Falkenhagen	Germany	Operation to begin in Q3 2013	HENG feed-in, up to 2vol.%	2 MW	Yes
Etogas Beta Plant (Audi e-gas project)	Germany	Operation to begin in 2013	Methanation with various CO <sub>2</sub> sources	6 MW	Yes
RH2-WKA	Germany	Operation to begin in 2013	HENG (and re-electrification)	1 MW (total)	Yes
GRHYD	France	Operation to begin in 2013	HENG up to 20vol.%	300-600 kW	Yes
Ontario Project (Hydrogenics & Enbridge)	Canada	Planned	HENG	1 MW	Yes
E.ON Hamburg-Reitbrook	Germany	Construction to begin Q2 2013	HENG from PEM electrolyzers	1 MW (€13 million)	Yes

1. Projects over 1 kW or feasibility studies of integrated projects from electrolysis to injection. Other projects in earlier stages of planning are not shown here: Electrochaea 2.1 MW demonstrator; Greenpeace Energy and Gasunie HENG project is on hold.

Source: 2. <http://www.northseapowertogas.com/>

# Hydrogen partially blended with natural gas can utilize existing gas infrastructure

## Status and outlook

Gas-distribution systems have carried gaseous hydrogen/methane mixtures, known as town gas, for 150 years – a practice that continues in places such as Hong Kong and Hawaii<sup>1</sup>. Technically, hydrogen-enriched natural gas [HENG] with a blending ratio below 5vol.% can be injected into the gas grid (figure 112), while blending ratios, of 17-25% are probably manageable with very little adjustment. A greater understanding of the effects of HENG is needed to better define these limitations. The potential is great, however. Even 5vol.% blending unlocks significant potential for hydrogen-based energy storage in regions with highly developed gas infrastructure. H<sub>2</sub> blending offers a low-cost solution for monetizing surplus electricity supply. The easiest option is to inject H<sub>2</sub> produced by decentralized electrolyzers into low/medium-pressure distribution pipelines, which have no buffer storage. Further economic benefits would come from HENG's recognition as a green fuel, because of its renewable-energy content. Hydrogen blending is gas-system specific and poses regulatory challenges.

**Figure 112: Principle of hydrogen blending into the natural gas grid**

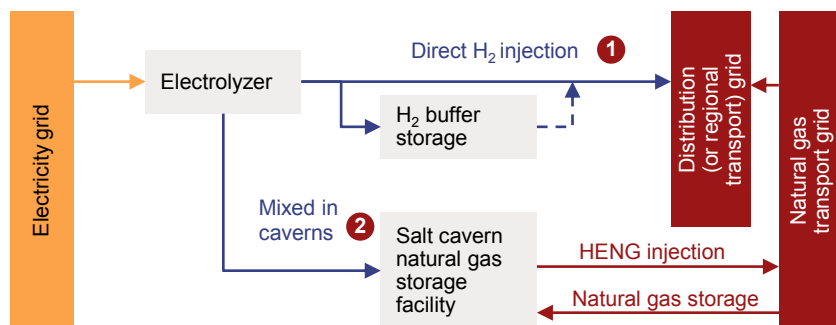

Existing natural gas infrastructure is used to store and transport H<sub>2</sub> in the form of . Blending is straightforward, in principle, and incurs no energy-efficiency penalties. But concentrations of hydrogen injected into the gas grid are limited and must be controlled to avoid the need for modifications to the grid and end-use applications. H<sub>2</sub> produced from an electrolyzer can be blended in two ways:

- **Direct injection** into the grid (at the distribution or regional transport level). Dedicated H<sub>2</sub> storage may be required to act as a buffer, depending on the size of the electrolyzer relative to the capacity of the pipeline.
- **Mixed in caverns:** H<sub>2</sub> is injected into existing underground gas-storage caverns, where it is stored until HENG is injected into the transport grid, when required.

1. In Hong Kong most of the gas distributed to households is composed of 50% H<sub>2</sub>, 30% CH<sub>4</sub> and 20% CO<sub>2</sub>; 2. Urban et al. (2009).  
Source: A.T. Kearney Energy Transition Institute analysis.

## Advantages over methanation

- Minimal investment (transport and storage infrastructure in place). Grid connection cost is estimated at €250 /kWch plus €1.5 /MWhch of operational feed-in costs<sup>2</sup>;
- No dedicated hydrogen storage required;
- Minimal additional energy losses (no additional processes);
- Substantial existing storage and transport capacity in countries with highly developed natural gas infrastructure, even with strict blending limits; and
- Lower carbon content of sales gas.

## Drawbacks over methanation

- H<sub>2</sub>/Natural gas ratio is technically limited to 17- 25vol.% in some parts of the distribution grid, and not above ~5vol.% in the transport grid;
- The H<sub>2</sub> blending limit is uncertain and very system specific, limited by grid integrity, safety, energy transport capacity, and by the specifications of end-use applications;
- Compliance with strict blending limits in a pipeline with large daily fluctuation in gas demand may require the costly adaptation of the real-time hydrogen-injection rate;
- The recovery of H<sub>2</sub> blended into natural gas is technically feasible, but uneconomic; and
- Legislation for HENG remains sparse.

## Densities of gaseous hydrogen compared with natural gas

	Hydrogen	Methane	Unit	Hydrogen vs. Methane
<b>Mass energy density</b>	39.39	15.4	kWh <sub>HHV</sub> /kg	<b>2.5 times more</b>
<b>Volumetric energy density</b>	3.3	10.8	kWh <sub>HHV</sub> /Nm <sup>3</sup>	<b>3.3 times less</b>
<b>Mass density</b>	0.084	0.65	kg/Nm <sup>3</sup>	<b>7.7 times less</b>

## Limits to hydrogen blending ratio (1/3): pipeline integrity and safety restrict blending to around 20vol.%

The concentration of H<sub>2</sub> that can be blended safely into existing natural gas networks, without the need for modification, is highly system/country specific, making regional legislation difficult to agree and necessarily cautious. Variable pipeline pressures may exacerbate the propagation and growth of pipeline cracks and faults<sup>1</sup>.

- **High- to medium-pressure pipelines** (16-80 bar) are often made of steel, where hydrogen-induced embrittlement can accelerate the growth of micro cracks, and compromise pipeline safety (figure 113). It is estimated that existing, unmodified steel pipes could sustain a **20vol.% H<sub>2</sub>**, and potentially up to 50vol.%, depending on the quality of the steel used<sup>1</sup>. But only after extensive testing, can gas pipelines be declared suitable for HENG.
- **Low-pressure pipelines** are generally<sup>2</sup> made of polymer, which does not suffer embrittlement and should easily accommodate an H<sub>2</sub> blend of **17-25vol.% H<sub>2</sub>** without the need for case-by-case testing<sup>3</sup>. Although H<sub>2</sub> diffuses through polymers five times faster than natural gas, the resulting energy losses are negligible, as are safety issues, because H<sub>2</sub> disperses very quickly into the atmosphere (Section 4.2).
- **Salt caverns** are perfectly suited to storing pure H<sub>2</sub>, or **HENG containing any percentage of H<sub>2</sub>**. However, without modification, equipment at gas-storage facilities (such as injection wells or compressors) could still be vulnerable to hydrogen damage. And, because these caverns are linked to the national gas grid, which is more sensitive to H<sub>2</sub> volumes, blending volumes will likely be limited to 5vol.% (see next slides). Other underground gas-storage facilities, such as deep aquifers or depleted gas fields, do not offer the same H<sub>2</sub>-storage qualities.

Figure 113: Metal cracking resulting from hydrogen embrittlement<sup>4</sup>



Figure 114: Typical natural gas network (French case)<sup>5</sup>

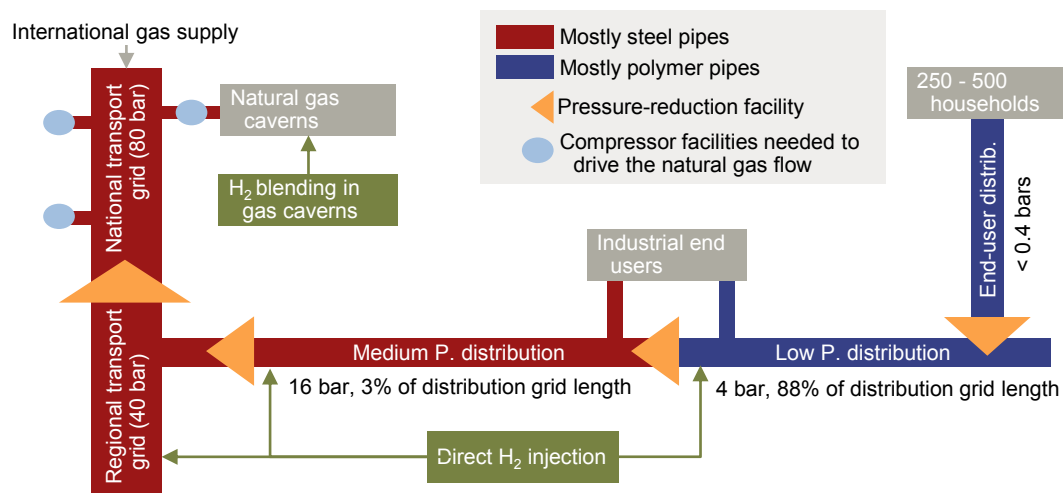

1. For this reason, dedicated pipelines supplying steady streams of H<sub>2</sub> to refineries encounter lower failure rates than pipelines that experience fluctuations in pressure – such as those supplying hydrogen for storage or use in mobility.

Source: 2. Old, low-pressure grids are sometimes made from metals, such as steel, or lead; 3. NaturalHy (2009); 4. Image courtesy of WWCPT; 5. A.T. Kearney Energy Transition Institute analysis, based on interview with GrDF.

## Limits to hydrogen blending ratio (2/3): higher volumes of blended H<sub>2</sub> reduce gas-grid capacity and efficiency

The blending of H<sub>2</sub> into the natural gas grid impairs pipeline hydraulics (pressure and flow rates), because the two gases do not share the same densities. Consequently, blending reduces the grid's capacity, efficiency and ability to provide short-term storage capacity in the pipelines (although these issues are insignificant for low-pressure infrastructure).

- The main limitation is that **the volume of hydrogen to be transported must be three times that of natural gas** to satisfy the same energy demand. Because pipeline pressure is limited for safety reasons, the volumetric flow rate must increase, but this causes a pressure drop in the pipe. Pressure drop is the grid's most important parameter, determining the compression power required to drive the energy flow. Consequently, both energy efficiency and transport capacity drop when H<sub>2</sub> is blended (figure 115).
- Another limiting factor to blending is the **reduction of methane held in the pipeline** – called line pack (figure 116) – because H<sub>2</sub> dilutes energy in the grid. The short-term supply security of the grid is dependent on line pack and is strictly regulated. The impact of H<sub>2</sub> blending on storage is shown in figure 115.

Overall, it is estimated that the negative effects to national grid performance are too high when the H<sub>2</sub> blending ratio is greater than 20vol.%. The most restrictive hydraulic constraint is to flexible pipeline storage capacity (in GWh), which drops by 20%; energy-transport capacity (in GW) is reduced by around 7%; and the energy efficiency of the grid decreases by 16%<sup>2</sup>.

**Figure 115: Effects of increasing hydrogen content on a 10 GW gas pipeline<sup>1</sup>**

Inlet pressure: 67 bar; unchanged pressure drop; volumetric flow rate: 1,000,000 m<sup>3</sup>/h

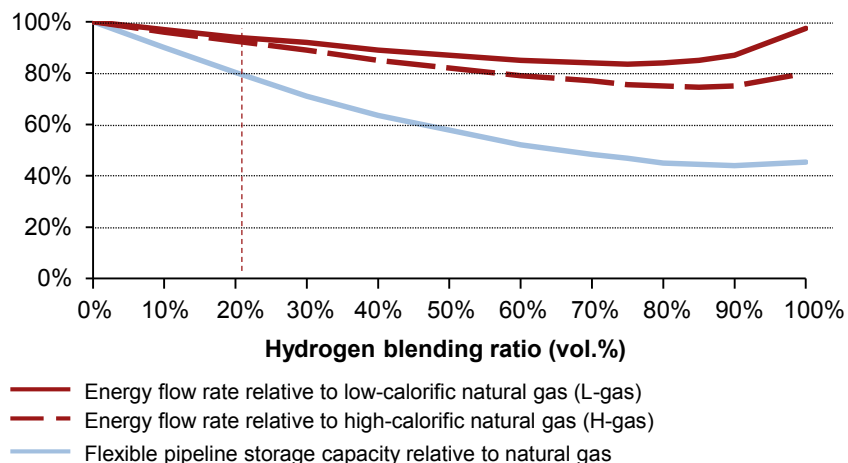

**Figure 116: Pipeline hydraulics explained**

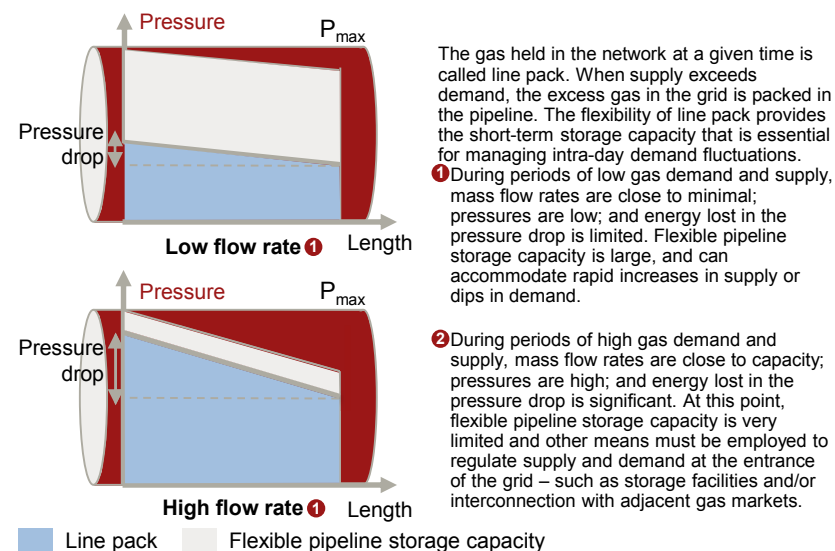

## Limits to hydrogen blending ratio (3/3): the sensitivity of some critical end-use applications to H<sub>2</sub> prevents a blending volume greater than 5vol.%

The combustion properties of gaseous H<sub>2</sub> change when it is added to natural gas, which can affect the performance of end-user appliances. Gas burners, boilers, gas turbines or internal combustion engines are set to operate within a certain range of feed-gas characteristics defined under the **Wobbe Index**<sup>1</sup> – a measure of the interchangeability of gases to end-use applications. Increasing the concentration of hydrogen in natural gas lowers the Wobbe index of the natural gas (figure 117), which reduces the energy released per volume combusted.

In gas burners and boilers, relatively high H<sub>2</sub> concentrations are tolerated (45% for burners according to European standards, figure 117). Safety issues may arise at a very high blending ratio (figure 118), but energy performance is not critically depleted.

Other critical appliances are very sensitive to the H<sub>2</sub> ratio, however, for which the fluctuation in gas quality is often a greater problem than the H<sub>2</sub> concentration. Recalibration of end-use applications is not viable if the blending ratio fluctuates, and dynamic measurement of gas quality is challenging. Critical appliances include:

- Natural gas turbines, which are optimized for a maximum 3vol.% H<sub>2</sub>, would require recalibration for higher blending ratios if they are to maintain optimal efficiency.
- Compressed natural gas [CNG] vehicles, which are subject to strict fuel standards (maximum 2vol.% H<sub>2</sub> in Europe). Higher blends are technically feasible and could improve performance, but would require engine recalibration (see Section 2.6).

For that reason, most countries apply stringent limitations to blending in the gas grid. The Netherlands has Europe's most generous limit, of 12vol.%; followed by France, 6vol.%; and Germany, 5vol.%<sup>2</sup>. Implementing a higher, uniform blending limit for Europe's entire natural gas grid would be challenging. But H<sub>2</sub> injection tends to happen downstream, and its proximity to consumers makes it relatively easy to identify end uses of H<sub>2</sub> and adjust blending limits accordingly. It should be possible to legislate in favor of higher blending ratios for HENG injection for sections of the grid with no critical appliances.

Figure 117: Wobbe index of hydrogen-enriched natural gas

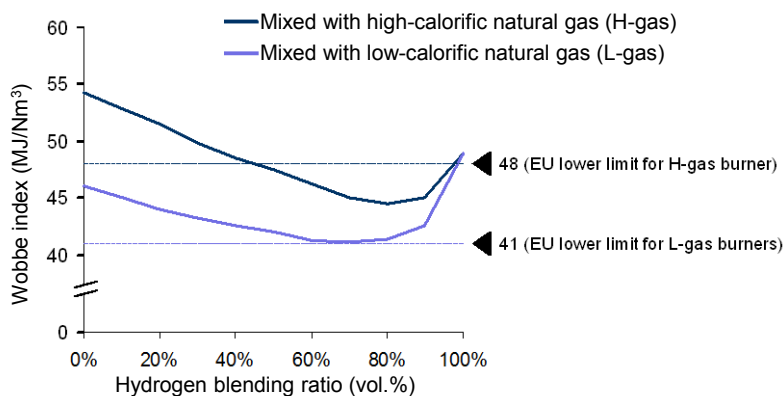
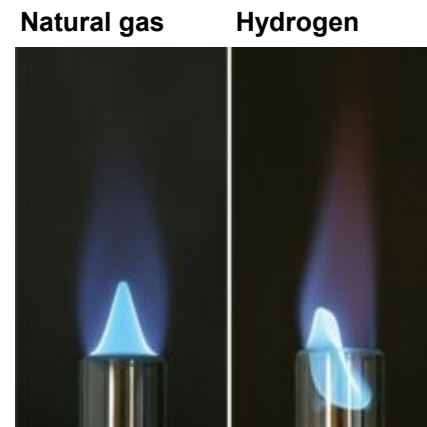

Figure 118: Natural gas vs. hydrogen flame combustion



- There are also safety risks associated with the end-use of HENG (see Section 4.2). A cooker designed for H-gas with a Wobbe index of 54 must increase the flow of gas when supplied with HENG. But this increase can cause the flame to become turbulent and may induce flashback. At a Wobbe index below 35, the gas may not even ignite, resulting in a very hazardous gas accumulation.

1. The Wobbe index is defined as the ratio of volumetric higher heating value divided by the square of the relative density compared with air. Source: Krausse et al. (2011); 2FuelCellToday (2013).

## Limits to hydrogen blending ratio (summary): although parts of the gas grid that do not feed critical appliances can tolerate up to 20vol.% H<sub>2</sub>, setting national limits above 5vol.% will be difficult

The most critical limitations for H<sub>2</sub> blending are the sensitivity of end-use appliances and of porous storage facilities<sup>2</sup> to high, or varying, H<sub>2</sub> concentrations. But natural gas infrastructure should stand 5vol.% blending at the national-grid level, and up to 20vol.% in the distribution or regional transport grid, when these do not connect to critical infrastructure.

To enable legislation for higher blending ratios, R&D is critical to refine the limits of each process and better understand the behavior of H<sub>2</sub> in the grid. The results of a study by DVGW shown that the most critical parts of the grid are gas turbines, compressed natural gas refueling stations, non-cavernous underground storage installations, such as aquifers or depleted hydrocarbon reservoirs, gas-compressor stations, industrial appliances and some measurement tools (figure 119).

Figure 119: Limit of H<sub>2</sub> blending along the natural gas infrastructure<sup>1</sup>

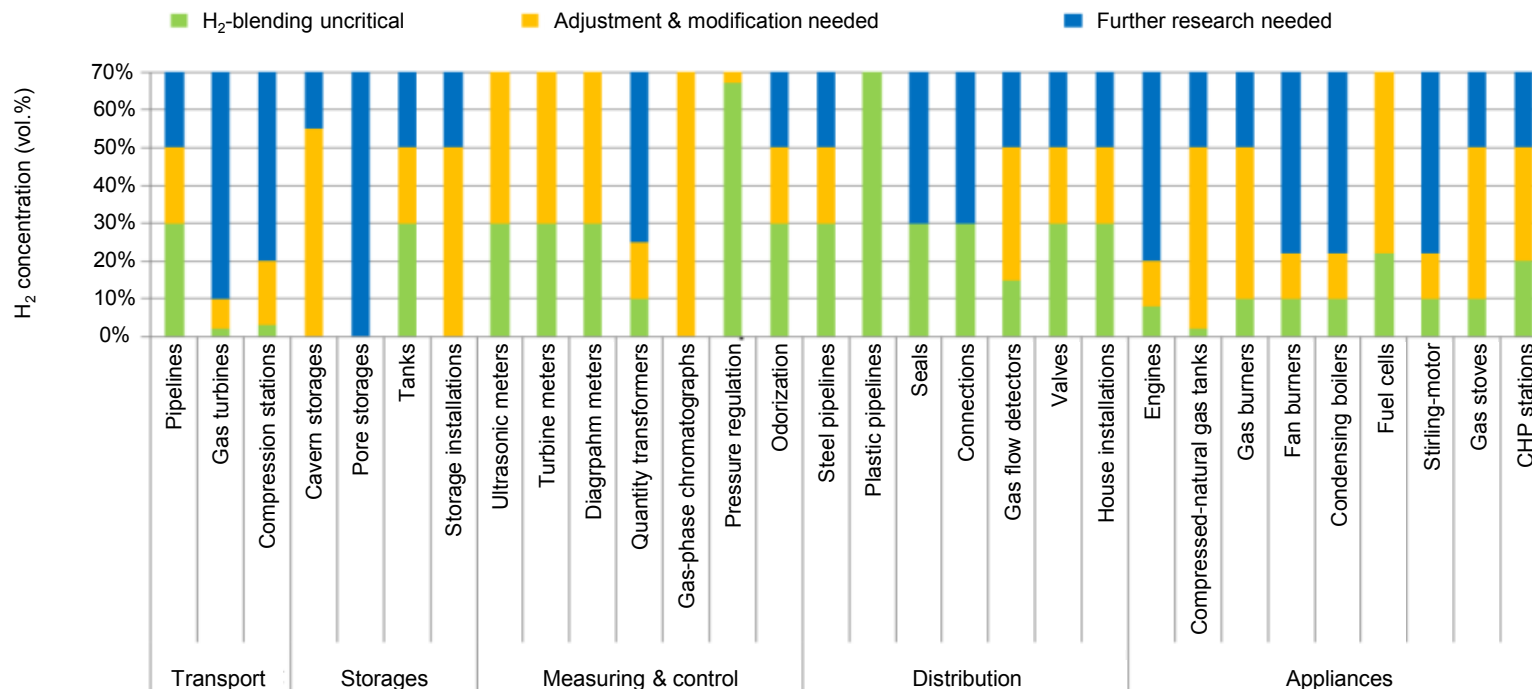

1. Aquifer or depleted oil and gas reservoirs.  
Source: 1. DVGW (2013).

## Project layout No. 1: direct injection into a gas grid – constraints are similar, but more stringent than for biomethane injection

**Under such a configuration, H<sub>2</sub> would be injected into a distribution or regional transport pipeline, with no critical downstream appliances.** The flow in distribution or regional pipelines is unidirectional, driven by successive pressure drops (unlike the national grid, which is driven by compression facilities and connected to gas caverns that generate two-way flows). This prevents back flows (for safety reasons) and limits H<sub>2</sub> compression needs (reducing costs). Legally, H<sub>2</sub> must be mixed with natural gas in a small buffer tank to control the H<sub>2</sub> volume before injection into the grid.

**The gas-network regulator defines the acceptable quality of HENG that can be injected into the grid, following the accurate inventory of critical downstream appliances.** A complication for H<sub>2</sub> projects, but not biomethane, is that some upstream H<sub>2</sub>-injection projects may already be supplying the grid, further diminishing the H<sub>2</sub>-injection potential of projects downstream. The accurate and dynamic measurement and modeling of H<sub>2</sub> concentrations is needed to ensure acceptable blending ratios, requiring smarter gas grids, as, at present, gas grid operators do not know exactly where the gas goes after injection. For now, regulation for direct H<sub>2</sub> injection is limited to very low concentrations, such as 5vol.%;

**The gas distributor manages the feed-in service (figure 120) and the cost of injection is relatively low compared with gas production<sup>1</sup>.** A HENG installation would be probably cheaper, as electrolytic hydrogen is extremely pure, especially in comparison with biomethane. A connection to the 40-bar regional grid, although more expensive because of greater compression needs, is feasible – most biomethane-injection capacity is connected to such pipelines in France; as is E.ON's Falkenhagen HENG project in Germany; and

**The H<sub>2</sub> producer controls the volume of HENG injected, ensuring compatibility with available pipeline capacity.** Gas flow rates through pipelines are variable, however, with most European countries' demand dropping significantly during the summer months, leading to a build-up of produced H<sub>2</sub>. Whenever possible, the HENG plant should be upstream from industrial gas consumers, ensuring consistent demand throughout the year. Alternatively, to avoid cutting H<sub>2</sub> production, the HENG project owner can either (i) limit the output of its electrolyzer below the summer minimum, reducing capital costs and idle time, and avoiding dynamic control of the injection rate; or (ii) utilize the versatility of H<sub>2</sub> to diversify revenues streams when the gas grid is congested (for example, combining the plant with a re-electrification system; a liquid methanol synthesis plant; or a distribution system to nearby H<sub>2</sub> refueling station).

**Figure 120: Typical biomethane connection installation<sup>2</sup>**

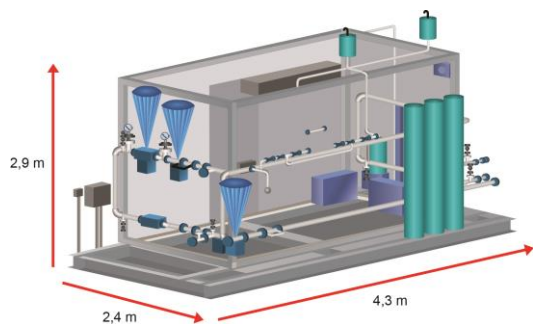

## Project layout No. 1: direct injection into a gas grid – the size of H<sub>2</sub>-injection facilities is likely to be limited by pipeline flow rate during low-consumption periods

When alternative H<sub>2</sub> end-use options are uneconomic, the capacity of an injection facility will be severely curtailed by the low pipeline flow rates of the summer months. The following results are based on the French natural gas market, assuming a maximum admissible H<sub>2</sub> blend of 20vol.% (equivalent to 7.1% in energy).

For a typical gas-distribution pipeline (figure 121), the flow rate drops by a factor of 15 in summer compared with winter. Assuming there are no upstream H<sub>2</sub>-injection projects – so gas flow in the pipeline has no H<sub>2</sub> input, and can be entirely displaced by a 20vol.% HENG blend – up to 17 MW<sub>ch</sub> H<sub>2</sub> per project could be injected continuously in a large, 16-bar distribution pipeline, and around 70 kW<sub>ch</sub> in a much smaller, 4-bar distribution pipeline<sup>1</sup>.

Theoretically, for a regional grid, H<sub>2</sub>-injection capacities should be higher and seasonal variations more smoothed. However, the authorized biomethane injection rate in France (figure 122), suggests an H<sub>2</sub>-injection rate no higher than 20vol.% would be permitted (less than 0.6 MW<sub>ch</sub> H<sub>2</sub>).

**Figure 121: Annual gas demand pattern in a medium-pressure (16 bar) distribution pipeline in the French GrDF network<sup>2</sup>**

Average flow rate (MW<sub>ch</sub>)

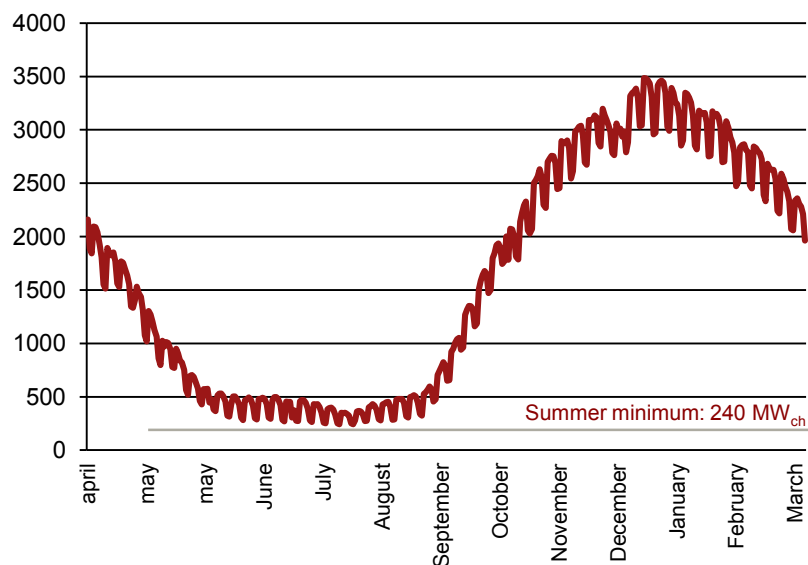

**Figure 122: Maximal continuous biomethane injection authorized in France's regional transport network, and estimated equivalent possible H<sub>2</sub> injection rate that respect a 20vol.% blending limit<sup>3</sup>**

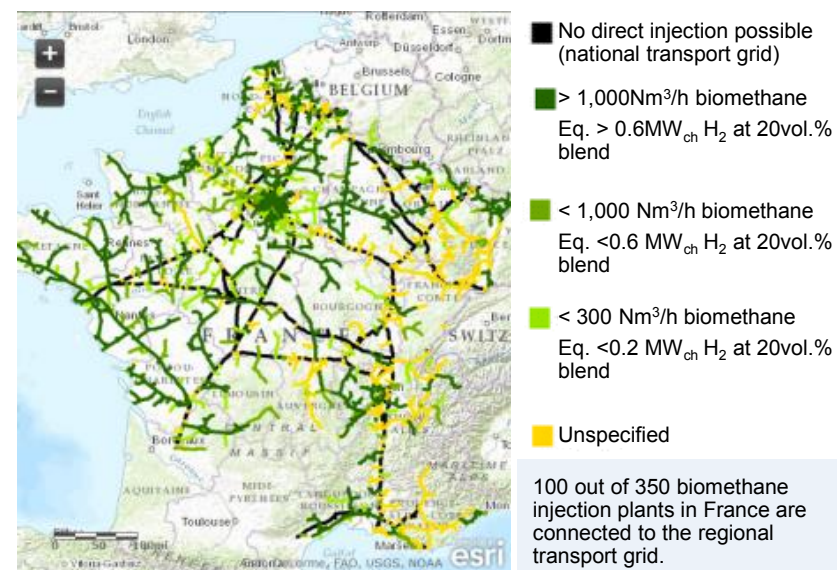

1. A typical 4 bar distribution pipe in residential area has a throughput of 1MW on average in summer; 2Typical aggregate pattern for an average-sized city, after the pressure-reduction facility linking the distribution pipeline to the transport one (year 2011-2012).

Source: 3Biomethane injection takes into account summer minimum, given by GRTGaz. Image courtesy of GRTGaz.

## Project layout No. 2: mixing H<sub>2</sub> in gas-storage caverns – although the blending ratio is limited to what is permissible in the transport grid, the capacity of salt caverns offers immense HENG storage opportunities

In such projects, P2G facilities are close to underground gas-storage facilities and produced H<sub>2</sub> is injected into these salt caverns and mixed with natural gas resources.

Salt caverns have the potential to hold unlimited H<sub>2</sub> concentrations. But maintaining sufficient gas-supply flexibility prevents the blending ratio in caverns from surpassing that in connected grid infrastructure. Because caverns are linked to the transport grid – with a blending ratio limited to 5vol.% – and can be called on at anytime to meet fluctuating gas demand (seasonal or short-term), **blending inside the cavern must never exceed 5vol.% (figure 123).**

**The sheer size of gas caverns still provides very large H<sub>2</sub>-storage capacities, even at 5vol.%. Salt caverns represent a significant and increasing proportion of the underground gas-storage capacity in Europe (10% of existing capacity and 21% of planned capacity)<sup>2</sup>. In Germany, this share amounts to an impressive 50%, offering a wealth of opportunities for P2G (see next slide).**

**A legal framework for H<sub>2</sub>-blending in gas caverns requires clarification**, and blending is not yet widely authorized in some countries – France, for example. But, in others, projects are forging ahead: Canada's Enbridge plans to blend electrolytic H<sub>2</sub>, sourced from a run-of-river power plant, into its own salt cavern at up to 3vol.%.

**Figure 123: Intra-day fluctuation of the French “H-gas” grid during a typical winter weekday, with constant gas supply equaling daily average demand<sup>1</sup> - % variation around the daily average gas demand (79 GWh/h)**

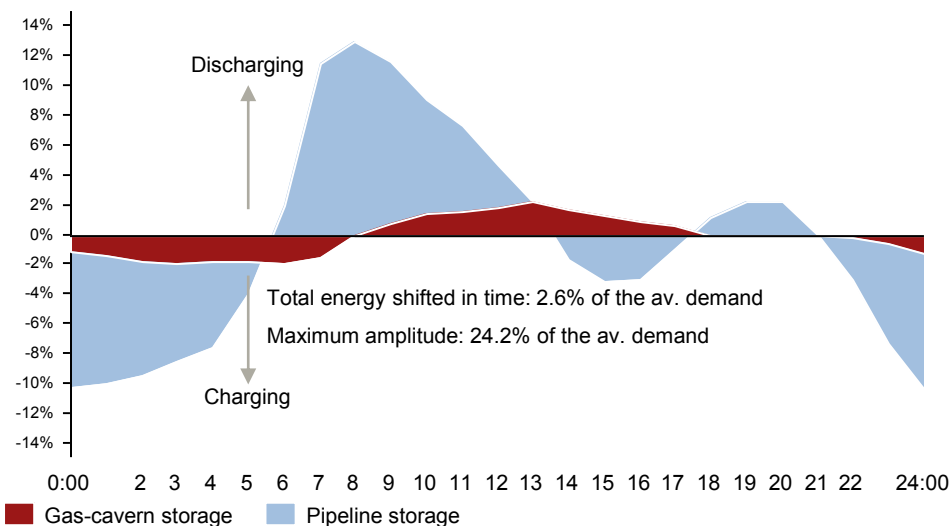

### How is security of gas supply ensured?

The volume of natural gas supplied to a transport grid is fixed for the day ahead and, generally, flows remain constant within a daily timeframe. Intra-day demand fluctuations are managed by the flexibility of gas volumes that can be held in pipelines (line pack). But during a cold snap, or an unexpected interruption to gas supply, storage facilities are called on to meet demand.

1. French GRT Gaz is a high-calorific gas network representing over 80% of French total natural gas consumption. Source: GRT Gaz (2010). 2Gas Infrastructure Europe (GIE) database, accessed in December 2012.

## H<sub>2</sub> blending is an elegant early stage solution for monetizing electricity surpluses in countries with highly developed natural gas infrastructure – German case study

The following case study demonstrates HENG's low-cost, early stage solution for monetizing surplus electricity output. It holds great promise in countries with highly developed natural gas infrastructure. The main benefit of this system is not to provide positive control reserves that secure electricity supply when demand is in excess, but negative control reserves that improve overall system efficiency.

**Figure 124 illustrates the potential of HENG in Germany.** H<sub>2</sub> blending at concentrations at 5vol.% or less, has virtually no effect on the gas grid (neither transportation nor distribution), or end-use applications. It does, however, reduce natural-gas consumption in proportion to the H<sub>2</sub> energy injected – a 5% volume H<sub>2</sub> blend is equivalent to a 1.5vol.% blend in energy content.

**Germany's underground gas storage has a capacity of 220 TWh<sub>ch</sub>, including 115 TWh<sub>ch</sub> in salt caverns.** The latter could store 1.7 TWh<sub>ch</sub> of H<sub>2</sub> blended at 5vol.%. 1.7 TWh<sub>ch</sub>. This is 40 times the energy capacity of pumped-hydro storage plants, and represents 20 days of Germany's intermittent renewable electricity production in 2012. It is also four times the electricity curtailed from the country's wind and solar-photovoltaic plants in the same year (0.4 TWh<sub>e</sub>).

Transformed into H<sub>2</sub>, injected into the gas grid, and sold on the European natural gas spot market, these resources could have generated revenues of €10 million. By 2030, the amount of electricity curtailed in Germany without P2G implementation is forecast to reach 2 TWh<sub>e</sub>, and potentially 43 TWh<sub>e</sub> in 2050<sup>1</sup>, when renewable electricity is predicted to account for 80% of generation.

**Figure 124: Order of magnitude of German HENG potential at 5vol.% blending<sup>3</sup>**

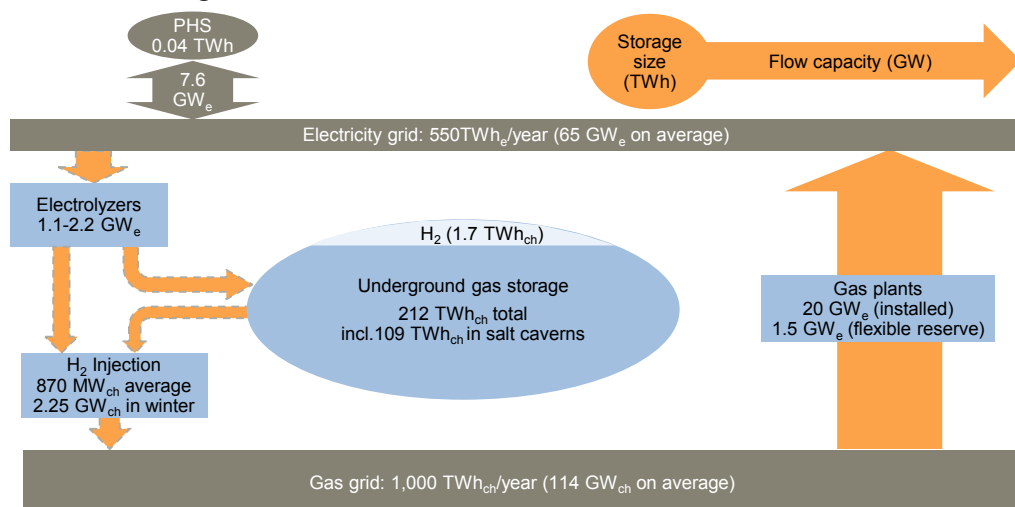

**The H<sub>2</sub> grid-injection rate (discharge rate) is limited by gas-grid dynamics:** on average, the German grid carries 1,000 TWh<sub>ch</sub> annually of natural gas, with demand at its lowest during the summer (around being at 58 GW<sub>ch</sub>). If H<sub>2</sub>-injection facilities are distributed evenly across the gas grid, 0.87 GW<sub>ch</sub> (5vol.%) could flow continuously during the year, with up to 2.25 GW<sub>ch</sub> in winter.

The electrolytic H<sub>2</sub>-production rate (charging rate) is technically unlimited, but subject to economic constraints. Assuming a minimum economically admissible load factor of 50% for the electrolyzers, up to 2.2 GW<sub>e</sub> of electrolyzer capacity could be built, while respecting the average H<sub>2</sub>-discharge constraint of 0.870 GW<sub>ch</sub><sup>2</sup>.

- This control-reserve electrolyzer capacity would provide a significant increase to the German power-generation control reserve of 9 GW (including 7.6 GW of pumped-storage hydro capacity).
- Decentralized electrolyzers could be activated tactically to provide relief to an oversupplied electricity-grid, where it is most needed.

1. Assuming 50% renewable-energy penetration in the electric grid in 2030 (80% in 2050), no international grid interconnections; 2Assuming electrolyzer efficiency of 78%.

Source: IER (2011); 3A.T. Kearney Energy Transition Institute analysis; ZFES (2012) for PHS capacity; Gas Infrastructure Europe (GIE) database accessed in June 2013 for underground gas storage capacity.

# Methanation produces synthetic natural gas from H<sub>2</sub> and CO<sub>2</sub>

## Status and outlook

The power-to-methane process reacts electrolytic H<sub>2</sub> with carbon dioxide to produce methane that can be injected into the natural gas grid ( $\text{CO}_2 + 4\text{H}_2 \rightarrow \text{CH}_4 + 2\text{H}_2\text{O}$  – figure 125). The siting of such plants is limited, economically, to locations near a CO<sub>2</sub> source and an existing gas pipeline. For now, the best CO<sub>2</sub> sources are biomethane feed-in plants, because of synergies between electrolysis, methanation and biogas production that lead to energy-efficiency gains and reduced land used for biomass cultivation. Methanation is a crucial conversion step towards decarbonized energy systems, based on low-carbon electricity and biomass. Oxy-combustion carbon-capture plants could also supply CO<sub>2</sub> too.

The methanation reaction has been well known since 1897, but integrated power-to-methane projects remain at an early demonstration phase. Two competing approaches are being tested – thermochemical and biological.

**Figure 125: Power-to-methane process**

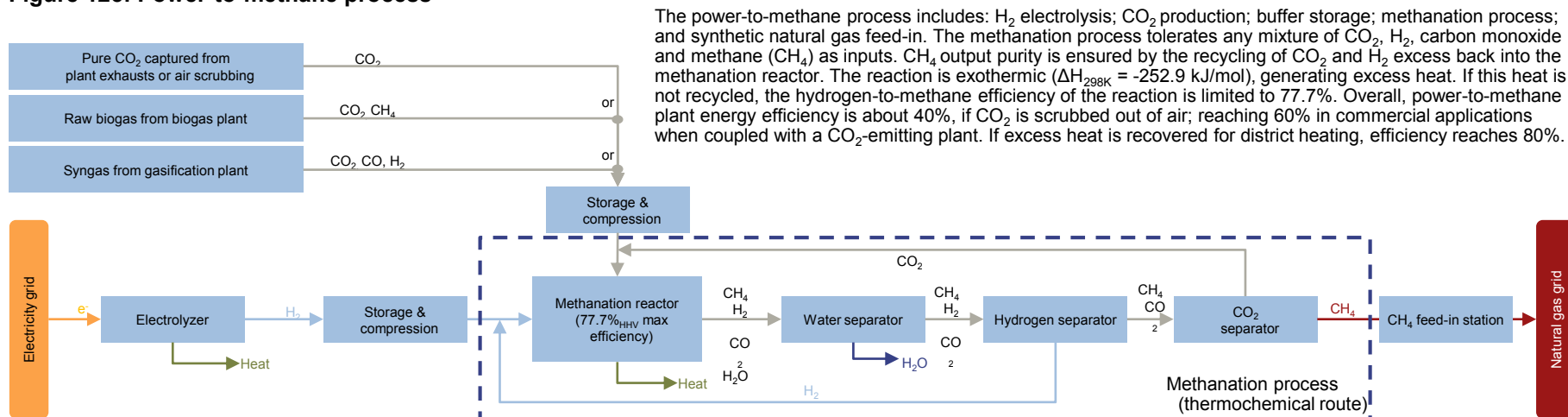

Note: This methanation process is based on thermochemical catalysis. Refer to the end of the Section 2.4 for the difference with biological catalysis.

Source: Detailed in the following slides.

## Advantages over H<sub>2</sub> blending

- There is no blending limit for injection into the gas grid;
- Produced synthetic methane is undistinguishable from natural gas;
- Methane is easier to manipulate than H<sub>2</sub>; and
- Recycling CO<sub>2</sub> emissions from biomass increases land-use yield efficiency.

## Disadvantages over H<sub>2</sub> blending

- Creates another step in the already long P2G value chain;
- Additional investments (methanation plant and H<sub>2</sub> buffer storage): over €2,000 /kW of capacity, decreasing to about €700 /kW in 2020;
- Lower energy efficiency: H<sub>2</sub>-to-methane reaction physically limited to 77.7%; power-to-methane plant 60% when commercial, 80% if heat is monetized; and
- Siting: near to an existing CO<sub>2</sub> source and natural gas pipeline.

## Methanation energy losses are uneconomic without local, industrial sources of CO<sub>2</sub>

Figure 126 charts the **mass flow** of physical matter transformed in the power-to-methane process. H<sub>2</sub> is so dense in energy that more than **five times as much carbon dioxide [CO<sub>2</sub>] as H<sub>2</sub> is needed to synthesize methane**. This huge CO<sub>2</sub> requirement necessitates the siting of power-to-methane projects close to industrial sources of CO<sub>2</sub>. Vast quantities of oxygen are also created during the electrolysis process, which can also be recycled.

Figure 127 shows the **energy flow** in the methanation and electrolysis processes. Noticeably, CO<sub>2</sub> capture from air is extremely energy intensive<sup>1</sup>, resulting in an efficiency drop from 60% to 39% for a power-to-methane project. And efficiency will be a further 1-3% lower, because of the balance of plant component, compression and transmission losses. However, **efficiency losses from electrolyzers and methanation reactors are in the form of heat, which can be recycled** to improve system efficiency (see next slide).

Note that energy and mass flows are not proportional. Chemical-energy flow ( $W_{ch}$ ) is proportional with physical-mass flow. This energy is the potential energy of combustion, also called calorific, or high heating value [HHV]. Only H<sub>2</sub> and methane molecules convey chemical energy. Other molecules involved in the power-to-methane process (H<sub>2</sub>O, CO<sub>2</sub> and O<sub>2</sub>) have no calorific value, but their value can be realized through recycling. Electrical energy flow ( $W_e$ ) does not involve the transfer of mass, but of electrons; and thermal energy losses ( $W_{th}$ ) result from the system exchanging heat with its environment.

**Figure 126: Mass flow chart of a 1 MW<sub>e</sub> power-to-methane process with pure CO<sub>2</sub> feed** (arrow width proportional to mass flow)

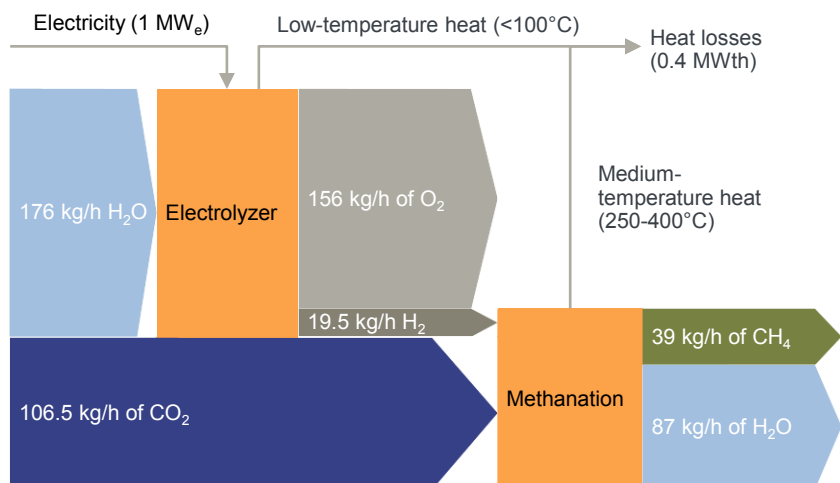

**Figure 127: Energy flow chart of a 1 MW<sub>e</sub> power-to-methane process with pure CO<sub>2</sub> feed scrubbed from air<sup>2</sup>** (arrow width proportional to energy flow)

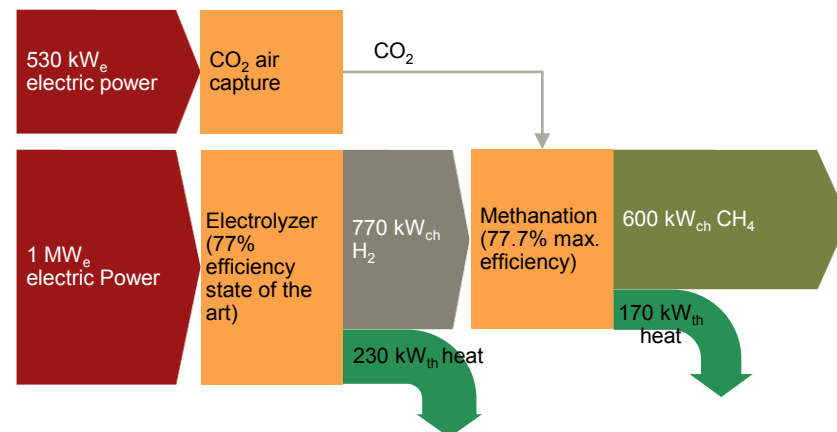

1. 8.2MJe/kgCO<sub>2</sub> is an average value for current commercial processes based on chemical absorption (Sterner 2009). 2Electrolyzer efficiency refers to system (not stack) efficiency of the best commercial electrolyzers. Methanation efficiency is the theoretical maximum for the methanation reaction.

## Biomethane feed-in plants are the best CO<sub>2</sub> source for methanation

**Raw biogas (a CO<sub>2</sub> and CH<sub>4</sub> mix), instead of pure CO<sub>2</sub>, can feed a methanation reactor without the need to separate the CO<sub>2</sub> and the CH<sub>4</sub>.** A biogas plant with a methanation reactor and an electrolyzer is also known as an electrolysis-assisted biomethane plant; or an H<sub>2</sub>-enriched biomethane plant. Figures 128 and 129 illustrate the multiple synergies derived from such a plant:

**For power-to-methane project owners, cost savings are made** because biomethane plants produce excess CO<sub>2</sub>, removing the need to pay for CO<sub>2</sub> or scrub it from air. The biomethane plant is also connected to the gas grid, so no new interconnection is required;

**For biomass-to-methane project owners, conversion efficiency is improved.** The process of transforming raw biogas into biomethane (CH<sub>4</sub>) before feeding it into the grid is redundant, reducing energy losses by around 10%. Excess heat from the methanation reactor is recycled into the biogas unit. If all heat can be recycled, biomass-to-biogas efficiency is boosted to 85.3%, from 68.7%.

**For the energy system as a whole, land use is optimized,** multiplying by up to 2.5 times the ratio of methane output to biomass input. Each MW<sub>e</sub> of generating capacity assisting the biomethane plant saves 162 hectares of land<sup>1</sup>, not accounting for land used to produce electricity. Yet solar-photovoltaic generation requires about 20-times less surface area per MWh of output than an energy crop. Onshore wind farms have energy densities similar to energy crops, but 95-99% of total land use remains available for farming.

**Figure 128: Mass flow chart of electrolysis-assisted biomethane plant** (illustrative order of magnitudes, if all heat from methanation could be recycled)

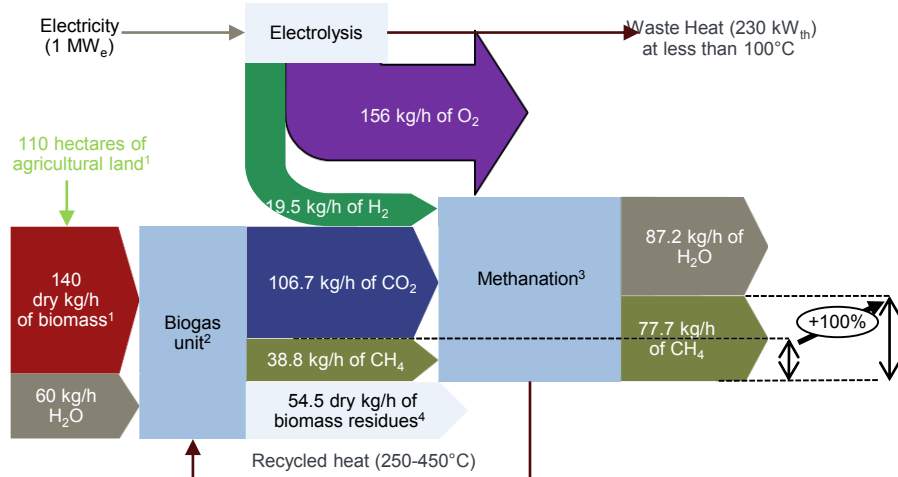

**Figure 129: Energy flow chart of electrolysis-assisted biomethane plant** (illustrative order of magnitudes)

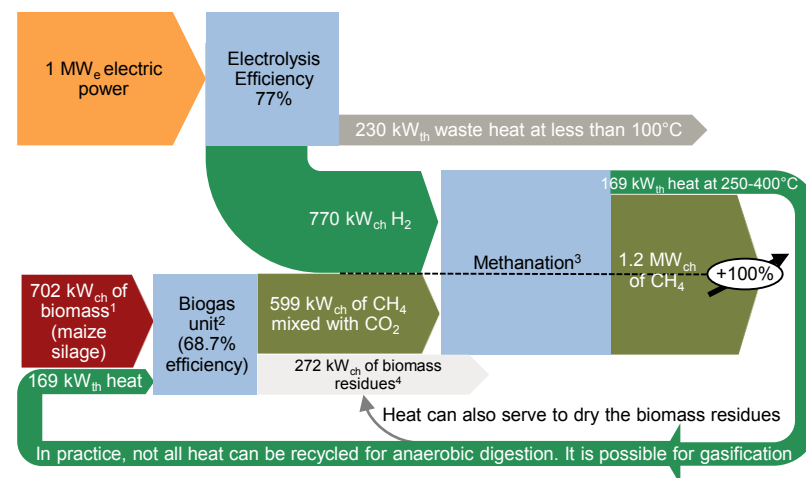

1. Biomass feedstock is a maize silage of 5kWhch/kg of dry matter, cultivated with a land yield of 0.63MWch per km<sup>2</sup>; 2the anaerobic digestion of maize silage requires heat and has a total efficiency of 68.7%. Heat is usually provided by burning some of the methane produced. Therefore, recycling heat from methanation increases the biomass-to-biogas efficiency of the unit; 3thermochemical methanation at 77.7% hydrogen-to-methane efficiency; 4Includes solid digestate and other energetic gases such as ammonia etc.

# The benefits of coupling power-to-methane with biomass-to-methane plants are realized with any biomass-transformation processes

## Figure 130: Electrolysis-assisted biomass plant layouts

### 1 H<sub>2</sub>-enriched biomethane plant

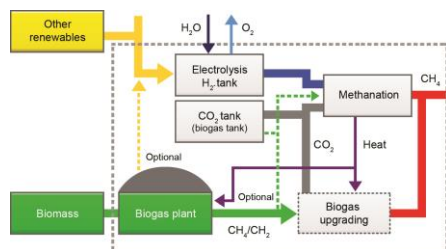

- Organic biomass anaerobic digestion plants with biomethane feed-in (or, simply, biomethane plants) are a commercial technology, with typical plant capacity of 5 MW. The digestion process has relatively low heat demand, which can be met by waste heat from methanation or electrolyzer processes. Enriching biomass with H<sub>2</sub> could increase the CH<sub>4</sub>-output to biomass-input ratio by 150%. Not all heat can be recycled, however: Mohseni et al. (2010) estimates CH<sub>4</sub> output is likely to increase by about 75%.

### 2 H<sub>2</sub>-enriched sewage fermentation plant

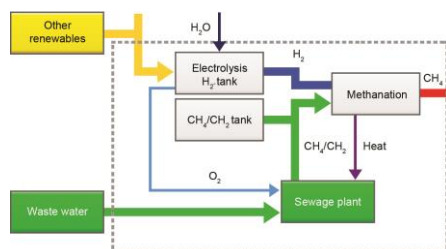

- Waste-management facilities, such as sewage plants and landfill sites, also emit large amounts of CO<sub>2</sub> during the fermentation process, which could be used for methanation, with heat from methanation recycled for fermentation. A further synergy is also possible: fermentation has a high demand for oxygen, which could be supplied by the electrolyzer.

### 3 H<sub>2</sub>-enriched biomass gasification plant

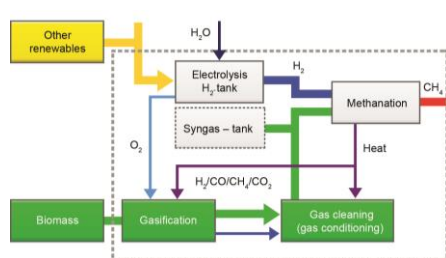

- Ligno-cellulosic biomass-gasification (or bio-SNG) plants are still in the demonstration phase, but operate optimally on a large scale (around 100 MW). They can produce almost any type of synthetic fuel through the intermediary production of syngas, which can be enriched with electrolytic H<sub>2</sub> and fed into the methanation reactor to produce SNG (synthetic natural gas). High heat demand for the gasification process can utilize waste heat from methanation, and use recycled oxygen co-produced from electrolysis to enhance performance. Overall, Mohseni et al. 2010 estimate SNG output increases by 110% when enriched with H<sub>2</sub>.

### Generalization

The chemical composition of biomass varies significantly, but can be regarded as comparable with that of cellulose C<sub>6</sub>(H<sub>2</sub>O)<sub>5</sub>, the most common organic compound on Earth. The carbon intensity, measured by the C/H ratio, is 0.6 – greater than that of methane (0.25).

H<sub>2</sub>-enrichment (or hydrogenation) reduces the carbon intensity of biomass to the equivalent of CH<sub>4</sub>:

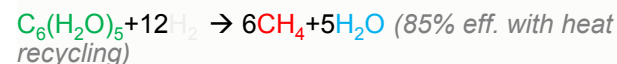

which is the sum of:

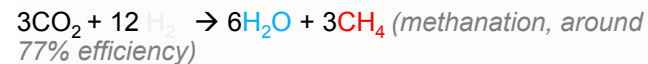
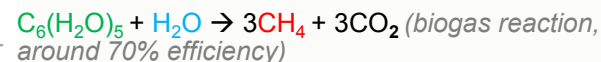

The main benefits of electricity and biomass coupling for methane production are:

- An electricity/biomass energy-input ratio of **1.4**;
- A methane yield increase of **75-110%**, or more; and
- A biomass conversion efficiency increase of more than **20%**.

Such synergies could make H<sub>2</sub> produced through electrolysis an attractive feedstock for biomass plants.

# CO<sub>2</sub> from biomass offers significant potential for methanation in Germany to reduce land-use competition

**Biomass conversion plants are well developed in Germany, as a result of subsidies established a decade ago.** According to ZFES (2012), Germany has 80% of the world's biogas plants – 5,800 facilities, producing 13.5 TWh<sub>ch</sub> a year of raw biogas. Most of these units are local combined heat and power [CHP] plants, burning raw biogas *in situ* without separating CO<sub>2</sub> from CH<sub>4</sub>. **CHP biogas plants could benefit from the addition of electrolyzers, but would not be considered P2G projects, and synergies are significantly fewer than with biomethane feed-in plants.**

The trend in Germany is increasingly towards biomethane feed-in rather than biogas power plants: at the end of 2011, 17% of the country's produced raw biogas was upgraded into biomethane and injected in the gas grid by 48 plants with a combined capacity of 340 MW<sub>ch</sub>. **Biomethane plants produce vast amounts of CO<sub>2</sub>, suitable as feedstock for methanation.** Potentially, 1.6 GW<sub>e</sub> of P2G methanation projects could be coupled with biomethane plants, feeding 6.4 TWh<sub>ch</sub> of electrolytic synthetic natural gas into the gas grid each year. This represents two months of Germany's intermittent renewable-electricity production in 2012, and is comparable to the 5vol.% blending of H<sub>2</sub>.

**A result of this rush for biomass is increased competition for farm land in Germany.** A striking example is the farming of corn: the land area dedicated to growing corn for bioenergy increased 11-fold since 2005, to represent 30% of the total area cultivated for corn in 2012 (figure 132). Consequently, the average cost of leasing a hectare of land has risen: in Schleswig-Holstein state, from €250 a year, to over €600 a year, since 2008<sup>2</sup>. In parallel, wind turbines are increasingly present on agricultural land (figure 131). **The synergies offered by coupling P2G and biomethane plants are obvious, as it could double the yield of each ton of biomass transformed.**

**Figure 131: Wind turbines near a new biogas plant in the German state of Lower Saxony<sup>3</sup>**



**Figure 132: Land used for corn cultivation in Germany<sup>4</sup> In million of hectare**

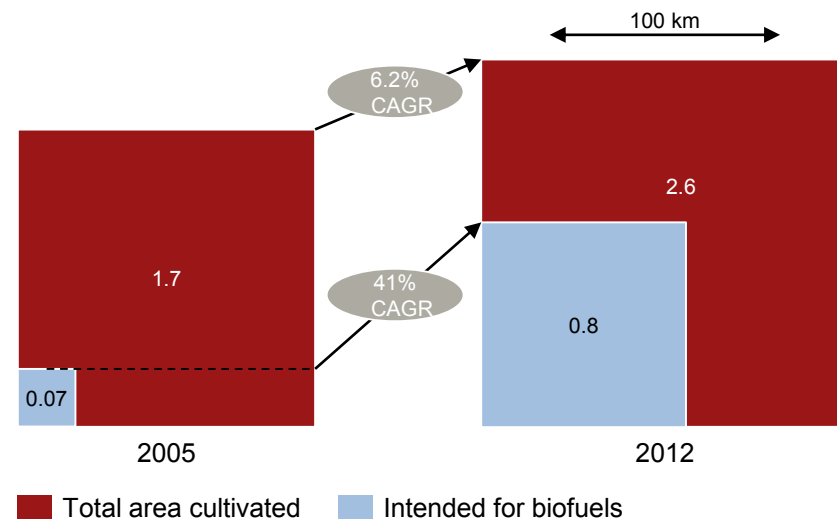

## Large P2G projects can source CO<sub>2</sub> from oxy-combustion carbon-capture plants, which can also recycle O<sub>2</sub> produced from water electrolysis

Most atmospheric CO<sub>2</sub> emissions are from the combustion of hydrocarbons in the presence of oxygen:  $C_xH_y + (x + \frac{y}{4})O_2 \rightarrow x CO_2 + \frac{y}{2} H_2O$ . **In oxy-combustion processes, O<sub>2</sub> (as opposed to air) is fed in for combustion, and exhaust gases are pure streams of CO<sub>2</sub> and water vapor, easily separable by condensation. This process is used in carbon-capture and storage initiatives to halt CO<sub>2</sub> emissions from industrial processes, such as coal-fired power, or steel plants; but it could also supply CO<sub>2</sub> for methanation in combined P2G and oxy-combustion systems (figure 133).**

**The numerous synergies between electrolysis, methanation and oxy-combustion are illustrated in figure 134.** All CO<sub>2</sub> from oxy-combustion flue gases feeds a methanation reactor after receiving light treatment. Three-quarters of all O<sub>2</sub> produced during electrolysis can be recycled to feed the oxy-combustion boiler, and ten percent of the excess heat from methanation can be recycled through the oxy-combustion plant.

**However, as industrial oxy-combustion plants are large, they require extremely large electrolyzers.** Consequently, in the short term, sourcing CO<sub>2</sub> from oxy-combustion is not an easy option. Industrial-scale carbon-recycling complexes are being evaluated by energy companies, and these could encompass CO<sub>2</sub>-intensive power and industrial plants, electrolyzers, methanation reactors, wind or solar-photovoltaic plants, all interlinked with the power grid, and CO<sub>2</sub>, O<sub>2</sub>, CH<sub>4</sub>, heat pipelines and storage tanks.

Figure 133: Coal power plant with integrated power-to-methane plant<sup>1</sup>

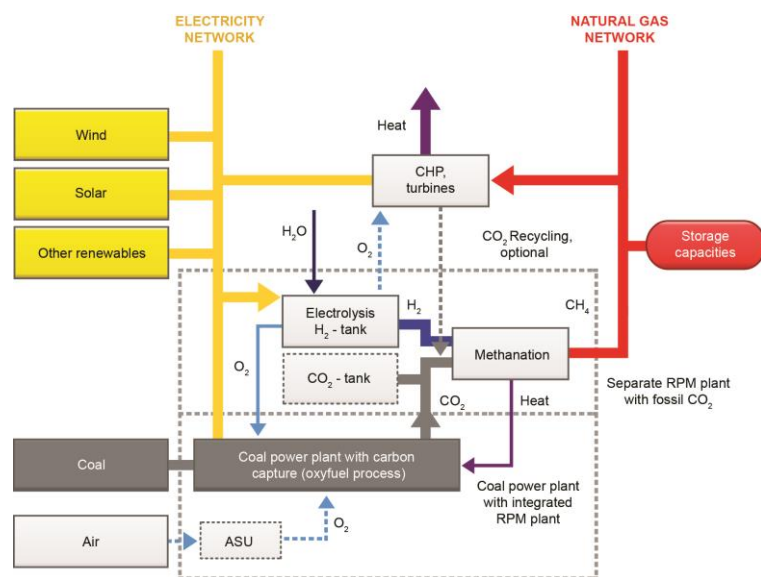

Figure 134: Physical flows of an oxy-combustion coal plant, coupled with a P2G plant recycling 100% of emitted CO<sub>2</sub> (Order of magnitude for a 550 MW<sub>e</sub> coal plant. Synergies in green)

	Oxy-combustion plant sourcing O <sub>2</sub> from power-to-methane plant		Power-to-methane sourcing CO <sub>2</sub> from oxy-combustion plant
<b>Hydrocarbon fuel (GW<sub>ch</sub>)</b>	Needs 1,440		
<b>Carbon dioxide (tons/hour)</b>	Produces 470	=	Needs 470
<b>Oxygen (tons/hour)</b>	Needs 530	≈	Produces 690
<b>Electricity (MW<sub>e</sub>)</b>	Produces 550	<	Needs 4,800
<b>Heat (MW<sub>th</sub>)</b>	Needs (for fuel pre heating)	<	Produces 780
<b>Water</b>	Needs (for cooling)		Needs
<b>Hydrogen (MW<sub>ch</sub>)</b>			Produces 3,400
<b>Methane (MW<sub>ch</sub>)</b>			Produces 2,600

1. RPM stands for Renewable Power Methane, referred to as power-to-methane in this report.; Avoiding air separation units for O<sub>2</sub> supply and recycling heat from methanation increases the coal plant efficiency to ~38% (A.T. Kearney Energy Transition Institute hypothesis). Source: Sterner (2009); 2 Stand alone oxy-combustion plant efficiency is 29.3%, NETL (2008).

## Two methanation methods are being demonstrated

There are two methods, competing methanation processes: thermochemical catalysis and biological methanation<sup>1</sup>.

**Thermochemical catalysis is the pre-eminent technology at present.** Invented by Paul Sabatier in 1897, it is well understood, but remains in the demonstration phase when integrated in P2G projects. Germany's Etogas is leading the way, with 25 kW<sub>ch</sub> and 250 kW<sub>ch</sub> reactors operating in February 2013, and a further 6 MW<sub>ch</sub> of capacity under construction. NASA, the US space agency, is examining the process as a means of converting the Martian CO<sub>2</sub> atmosphere into CH<sub>4</sub> fuel and water for astronaut life-support systems; and

**Biological methanation is an adaptation of the anaerobic-digestion process used in biogas plants.** Applying this to P2G facilities is a relatively new concept and, as yet, undemonstrated; the leading companies are Electrochaea (which has a 250 kW plant under construction in Denmark and a 2.1 MW project awaiting a final investment decision) and MicrobEnergy GmbH.

**Both processes have advantages and drawbacks (figure 135),** but share two fundamental characteristics: the potential utilization of any mixture of CO<sub>2</sub>, H<sub>2</sub>, CO, CH<sub>4</sub>, H<sub>2</sub>O as feedstock, allowing coupling with biogas, gasification or carbon-capture plants; and, an energy-conversion efficiency theoretically limited to 77.7% without heat recovery.

Figure 135: Methanation methods compared<sup>4</sup>

	Thermochemical catalysis	Biological catalysis
<b>Comparative advantages (summary)</b>	<ul style="list-style-type: none"> <li>• Technically more mature</li> <li>• Possibility of up-scaling to hundreds of MW</li> <li>• Easier to control</li> <li>• Lower maintenance time</li> <li>• Higher temperature waste heat for recycling</li> </ul>	<ul style="list-style-type: none"> <li>• Potentially lower costs (low temperature &amp; pressure, no metal catalyst)</li> <li>• Tolerance to impurities in the feed gas, allowing coupling with biogas</li> <li>• Flexibility in ramping rate and operational load</li> <li>• More adapted to small scale/decentralized (&lt;10MW plant)</li> </ul>
<b>Technical maturity</b>	Demonstration phase (6 MW being built)	Early demonstration phase (250 kW being built)
<b>Input gas</b>	any mix of CO <sub>2</sub> , H <sub>2</sub> , CO, CH <sub>4</sub> , H <sub>2</sub> O	
<b>Contamination tolerance</b>	Low tolerance to H <sub>2</sub> S and O <sub>2</sub> Requires dehydration of H <sub>2</sub> after electrolysis	High tolerance to impurities, H <sub>2</sub> S, and water vapor. Limited tolerance to oxygen
<b>Temperature</b>	250-400°C	60-70°C
<b>Pressure</b>	1-100 bar	1 bar
<b>Methane purity (conversion yield<sup>1</sup>)</b>	92-96% depending on catalyst and flow rate through the reactor	~98-99%
<b>Hydrogen-to-methane energy efficiency<sup>3</sup></b>	77.7% theoretical limit without heat recovery	
<b>Power-to-methane energy efficiency<sup>3</sup></b>	~60% excl. heat recovery; ~80% incl.	Today: 54.7% excl. heat recovery; 73.5% incl. Target: 63.2% excl. heat recovery; 82% incl.
<b>Methane flow rate per reactor volume</b>	Very high	Sufficient for decentralized plant: 0.5 MW per m <sup>3</sup>
<b>Flexibility (ramp up/down between 0%-90%)</b>	30 minutes to 1 hour in cold start	Second to minutes

1. Technical details follow in the next two slides; 2Conversion yield refers to the ratio of CO<sub>2</sub> molecules actually converted into CH<sub>4</sub> when enriched with H<sub>2</sub> in stoichiometric quantity; 3Energy efficiency in HHV, assuming free CO<sub>2</sub> supply.

Source: 4A.T. Kearney Energy Transition Institute analysis, based on interviews with methanation technology developers.

## Methanation method No. 1: thermochemical catalysis, based on the Sabatier reaction, enhanced by metal catalysts and controlled by temperature

The **Sabatier reaction** ( $\text{CO}_2 + 4\text{H}_2 \rightleftharpoons \text{CH}_4 + 2\text{H}_2\text{O}$ ) is a two-way reaction, which takes place in a thermochemical reactor. From left to right, the process is methanation; from right to left, it is methane reforming. **Figure 137 shows that the percentage of  $\text{H}_2$  converted into  $\text{CH}_4$  (the yield<sup>1</sup>), in a limited amount of time is influenced by the catalyst used and the reactor temperature.**

**At room temperature,  $\text{H}_2$  and  $\text{CO}_2$  should spontaneously react to form  $\text{CH}_4$ , but the chemical reaction is very slow without the assistance of a metal catalyst, which can be expensive.** The best catalysts are made of nickel, which is thinly coated on a cheaper support material, allowing the maximum possible contact area relative to its size (figure 136). **The reactor temperature is set to optimize the  $\text{CO}_2$ -conversion yield after it has cycled once through the reactor.** Because the methanation reaction is exothermic, the reactor heats up and must be cooled to maintain optimal temperature; otherwise, the methanation yield decreases and, at temperatures above  $500^\circ\text{C}$ , the reaction starts to reverse (methane reforming).

Compared with typical petrochemicals processes, methanation's thermodynamic performance provides high yield at low temperature ( $300^\circ\text{C}$ ). **This makes it relatively easy to operate, control and upscale.** From a cold start, a multi-MW thermochemical methanation reactor would take around an hour to reach  $300^\circ\text{C}$  and 90% load, however, so  $\text{H}_2$  and  $\text{CO}_2$  buffers would be required to allow continuous methanation operations despite extreme fluctuations in electrolyzer load.

**One significant uncertainty surrounding thermochemical methanation is the extent to which raw biogas, from digestion or fermentation plants, can be utilized without expensive pre-treatments.** Impurities in biogas, such as  $\text{H}_2\text{S}$ , will oxidize metal catalysts.

**Figure 136: Thermochemical methanation reactor with surface catalysis<sup>2</sup> (illustrative)**

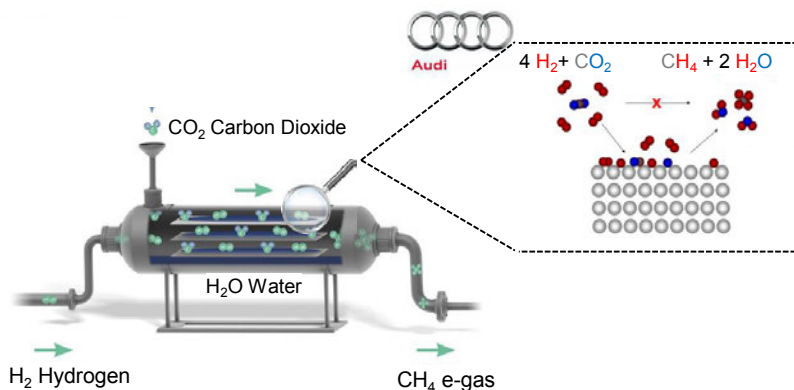

**Figure 137: Sabatier reaction conversion yield under atmospheric conditions, after the gases pass through the reactor<sup>2</sup>**

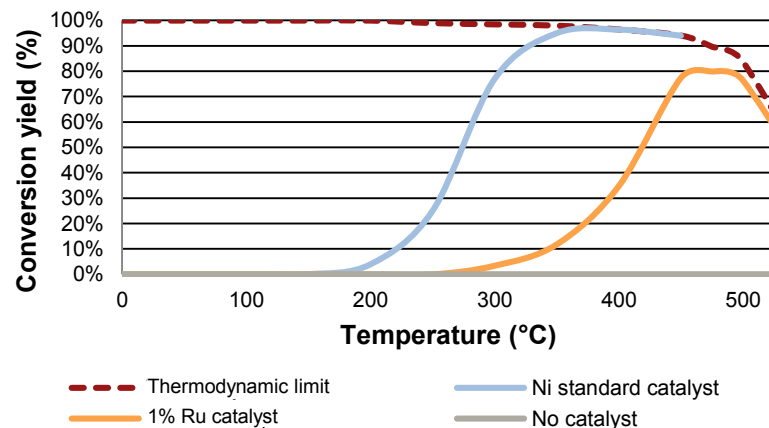

1. The yield of the reaction is not to be confused with energy efficiency. A reaction with 100% yield would convert all  $\text{CO}_2$  and  $\text{H}_2$  molecules into methane, but would still be exothermic, with an energy efficiency of maximum 77.7%.

Source: Image courtesy of: 2Audi e-gas project website, and adapted to Borgschulte (2012).

## Methanation method No. 2: biological catalysis, based on controlled methanogenesis by archaea

**Cultivating methanogenic archaeas (figure 138) provides another route to methanation. These organisms digest CO<sub>2</sub> and H<sub>2</sub> to produce CH<sub>4</sub> in a low-temperature reactor (60-70°C), at ambient pressure and in the absence of oxygen (anaerobic conditions).** These organisms are, in principle, similar to those used in the final stages of conventional biogas plants, and are selected for their efficiency and robustness.

**Although methanogenesis is a mature concept for biogas, most integrated P2G projects are using thermochemical methanation. But methanogenesis offers many advantages over thermochemical methanation<sup>1</sup>.** (1) The methanation reactor has a simpler design, resulting in 25% lower investments costs and lower operational costs. (2) Atmospheric pressure and low temperature reduce operational risks. (3) The reactor is very reactive for intermittent operations: a cold start from 0-90% can be achieved in less than a minute. (4) Feed gas need not to be purified: raw biogas with H<sub>2</sub>S can be used, while non-dehydrated H<sub>2</sub>, straight from the electrolyzer, avoids the need for drying, reducing electrolyzer investment by 25%. (5) Its energy efficiency can reach 63% without heat recovery, and 79% with heat recovery.

**The biological process remains to be demonstrated on a commercial scale,** however, and engineering difficulties encountered with algae biofuels show that biological processes are often harder to streamline and control when scaled-up from the lab. Additionally, biological methanation plants are much bigger than thermochemical facilities. An 8 m<sup>3</sup> reactor could produce 4 MW<sub>ch</sub> of methane – a good performance for an atmospheric reactor, but could require a very large plant for centralized production (above 10 MW).

**Figure 138: M. smithii methanogenic archaea<sup>2</sup>**



Archaea are single-cell living organisms. They differ from bacteria, plant or animal cells in that they lack a defined nucleus. They can thrive under extreme conditions, deprived of sunlight and oxygen, obtaining energy from chemical reactions with energetic molecules.

Methanogenic archaea consume H<sub>2</sub> molecules to produce methane. They commonly inhabit wetlands and animal guts. The archaea population use the chemical energy gained during the methanation reaction to grow, limiting energy efficiency to 77.7% physically. But unlike in the thermochemical process, energy losses in the form of heat are insignificant.

**Figure 139: Electrochaea's 250 kW biological methanation reactor for the Foulum project (Danish Biogas Demonstration project)<sup>3</sup>**



## Power-to-methane production costs are still very high

The cost breakdown for an integrated power-to-methane plant, with thermochemical catalysis, comprises:

- **Plant investment:** Sterner (2009) estimates that a 5-10 MW<sub>e</sub> plant today would cost €2,000 /kW<sub>e</sub>; while German research institute ZSW predicts the first commercial projects (of a similar size) will cost around €3,000 /kW<sub>e</sub>, by 2015. Beyond 2020, and provided plant up-scaling to 20-200 MW<sub>e</sub> is achieved, costs could drop to €1,000 /kW<sub>e</sub>. Around half the capital cost is for the electrolyzer;
- **Fixed operation and maintenance:** estimated at 3% of total investment;
- **Variable operation and maintenance;** consisting mainly of CO<sub>2</sub> and electricity requirements (CO<sub>2</sub> is assumed to be free in the following analysis); and
- **Grid connection:** feed-in infrastructure and installation is estimated at €250 /kW<sub>ch</sub> of SNG, plus €1.5 /MWh<sub>ch</sub> of operational costs<sup>3</sup>.

Figure 141 shows the expected, levelized cost of SNG production in 2020, based on fixed, low-cost electricity supply. However, grid electricity prices are never constant throughout the year. An electricity-price arbitrage strategy, based on the spot or balancing market, could further reduce the levelized cost of SNG at low load factors (see Section 3.2, business case No. 1). **By-products, such as oxygen and heat, can be sold to reduce the levelized costs of the SNG further** (see Section 3.2, business case No. 4). And a P2G plant can benefit financially from the neutral carbon footprint of the methanation process. If CO<sub>2</sub> is sourced from polluting sources or biomass (preventing its release into the atmosphere), and if electricity supply has no carbon footprint, electrolytic SNG could be sold at premium prices. Such a process could require new regulatory mechanisms to enable trading of low-carbon certificates between the power and gas sectors (see section 5.2)

**Figure 140: Targeted capital-cost reductions of power-to-methane plant<sup>1</sup>** Targets are sourced from proponents of the technology and have to be treated with caution

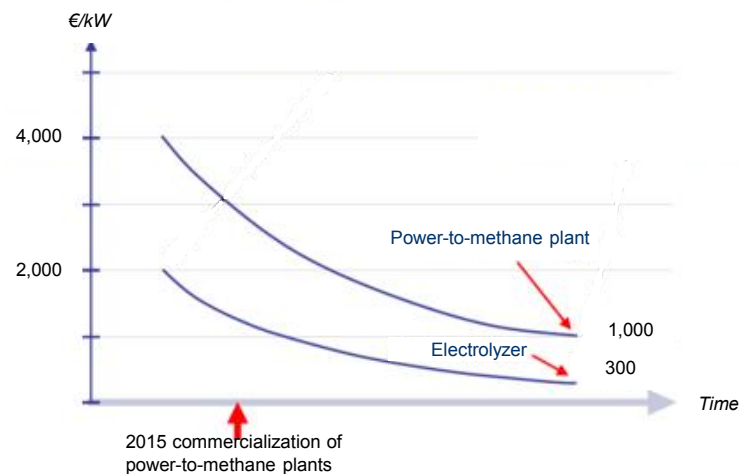

**Figure 141: Levelized costs of SNG from power-to-methane plant in 2020<sup>2</sup>** Capital cost €1,200 /kW; efficiency 55%<sub>HHV</sub>

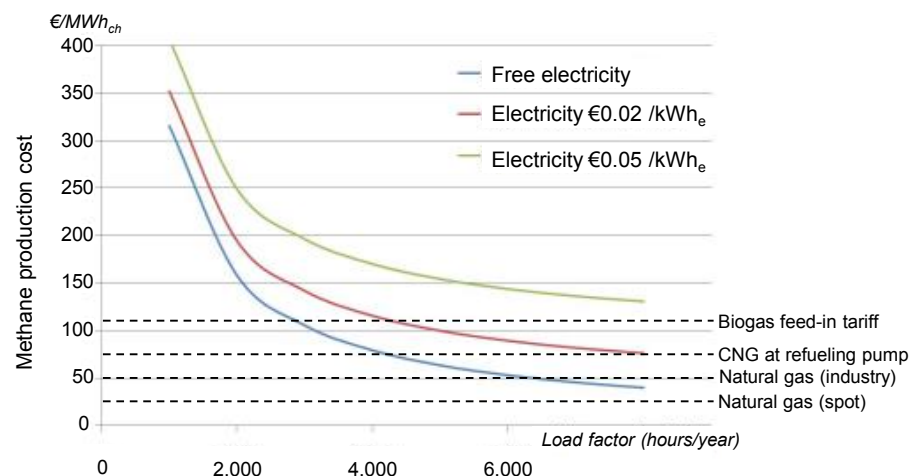

## Sources: section 2.4

- Borgschulte (2012), *“Chemical energy Storage Synthetic fuels: Catalysis and Synthetic Fuels”*, Andreas Borgschulte  
 Deutscher Verein des Gas- und Wasserfaches – DVGW (2013), *“DVGW-Forschungsprojekt Energiespeichkonzepte”*, Thorsten Brümmer, presentation at European Commission workshop H2 in the economy.
- FuelCellToday (2013), *“Water Electrolysis & Renewable Energy Systems”*
- Gahleitner (2012), *“Hydrogen from renewable electricity: An international review of power-to-gas pilot plants for stationary applications”*, Gerda Gahleitner, International Journal of Hydrogen Energy, Vo. 38, pp. 2039-2061
- Gas Infrastructure Europe – GIE, database <http://www.gie.eu.com/index.php/maps-data/gse-storage-map>
- Gondal et al. (2011), *“Prospects of natural gas pipeline infrastructure in hydrogen transportation”*, Irfan Ahmad Gondal, Mehmet H. Sahin, Mukhtar Hussain Sahir, International Journal of Energy Research
- GrDF (2012), *“L’injection de biométhane dans le réseau de gaz naturel”*, Claire Brecq, presentation for the 10<sup>th</sup> Conférence sur le biogaz et le biométhane
- GRT Gaz (2010), *“Etude de la capacité des infrastructures gazières à répondre aux besoins des centrales prévues”*
- Germany Trade & Invest – GTAI, website: <http://www.gtai.de/GTAI/Navigation/EN/Invest/Industries/Smarter-business/Smart-mobility/national-hydrogen-and-fuel-cell-technology-innovation-programme.html>
- Haeseldockx (2006), *“Concrete transition issues towards a fully-fledge use of hydrogen as an energy carrier”*, Dries Haeseldockx, Katholieke Universiteit Leuven
- Hernandez-Rodriguez (2012), *“Multiobjective optimization of natural gas transportation networks”*, Guillermo Hernandez-Rodriguez
- Institute for Energy Economics and the Rational Use of Energy – IER (2011): *“The system costs of nuclear and renewable power production - a case study”*, Universität Stuttgart
- Krause et al. (2011), *“Wasserstoff aus Windstrom als chemischer Energiespeicher im Erdgasnetz und die Rolle der Brennstoffzellen zur Rückverstromung”*, Hartmut Krause, Gert Müller-Syring, Presentation for Kooperationsforum – Technologien stationärer Stromspeicher
- Mohseni et al. (2010), *“Biogas from renewable electricity – increasing a climate neutral fuel supply”*; Farzad Mohseni, Mimmi Magnusson, Martin Görling, Per Alvfors
- NaturalHy (2009), *“Using the natural gas network”*
- National Energy Technology Laboratory – NETL (2008), *“Pulverized Coal Oxycombustion Power Plants, Volume 1: Bituminous Coal to Electricity”*;
- National Renewable Energy Laboratory – NREL (2009), *“Land-Use Requirements of Modern Wind Power Plants in the United States”*
- Sterner (2009), *“Bioenergy and renewable power methane in integrated 100% renewable energy systems”*, Michael Sterner, Kassel University Press
- Urban et al. (2009), *“BMBF-Verbundprojekt Biogaseinspeisung- Band 4”*, Wolfgang Urban, Heiko Lohmann, Kai Girod, Fraunhofer Institute
- Wenzel (2010), *“Breaking the biomass bottleneck of the fossil free society”*, Henrik Wenzel, report for the Danish Climate think tank CONCITO
- Zentrum für Sonnenenergie- und Wasserstoff-Forschung – ZSW (2012), *“Technik und Ziele der 250 kW<sub>el</sub>-Power-to-Gas-Forschungsanlage”*
- Zentrum Für Energieforschung Stuttgart – ZFES (2012): *“Stromspeicherpotenziale für Deutschland”*

## 2.5 - Hydrogen-to-liquid fuels



## Summary & key findings: section 2.5

- 1. A number of synthetic fuels can be synthesized from hydrogen and carbon sources.** Also known as C-H-O syngas, they are chemically similar to their fossil-fuel counterparts:
  - If carbon is sourced from CO<sub>2</sub>, the synthesis process (called CO<sub>2</sub>-hydrogenation) leads only to short molecules, such as methane, methanol and dimethyl ether; while
  - Sourcing carbon from CO molecules to hydrogenate syngas (CO + H<sub>2</sub>) is simpler than sourcing carbon from CO<sub>2</sub> molecules, which are less reactive; CO-hydrogenation is, as a result, a more common and mature process. The H/C ratio of the syngas determines the accessible range of H/C ratios of the synthesized fuel.
- 2. Liquid fuels are critically important in transport. They have a much higher volumetric energy density than gaseous fuels even when gaseous fuels have been compressed to very high pressure.**
- 3. Drop-in liquid fuels (e.g. synthesized diesel or gasoline) have the best energy-carrier properties (energy density) and existing technologies do not need to be retrofitted in order to use them. However, they are much harder to synthesize from hydrogen and carbon than methanol.** Two commercial, industrial processes have been developed. But both are cumbersome and economic only on a large scale. Consequently, no integrated power-to-gasoline or -diesel plants have been built. The two processes are:
  - Fischer-Tropsch – based on syngas that could be enriched with electrolytic hydrogen, or produced directly by SOECs at the desired H/C ratio; and
  - Methanol-to-gasoline [MtG] – for which, electrolytic methanol could be used as the feedstock.
- 4. Methanol is the most promising electrolytic liquid syngas in competition with methane** (its H/C ratio is equal to that of methane). Methanol is among the top-10 organic chemicals by quantity manufactured, and can be used as a gasoline substitute. However, for very high blending ratios or for complete gasoline substitution, dedicated methanol infrastructure would be needed, which would undermine methanol's advantage over hydrogen. The hydrogen-to-methanol process is very similar to methanation. There are three renewable electrolytic-methanol production options that utilize electrolyzers:
  - Direct hydrogenation of CO<sub>2</sub> into methanol is very similar to the thermochemical methanation reaction (same efficiency, but slightly more expensive). A 5 MW plant is operating in Iceland, utilizing geothermal electricity and CO<sub>2</sub> sources;
  - Combined with biomethanol plants, to enrich the syngas produced from biomass and H<sub>2</sub>, before CO-hydrogenation; and
  - With direct methanol solid oxide electrolyzer cells [SOEC]. This process converts water, electricity and CO<sub>2</sub> into methanol in a single step, using a high-temperature SOEC stack. It would allow for flexible and efficient syngas production at any scale, but is at the R&D stage.



# The critical need for liquid fuels drives power-to-synfuels beyond methanation

All synfuels derived from water and CO<sub>2</sub> are composed of hydrogen, carbon or oxygen atoms, and are also known as C-H-O synfuels (figure 143). The combustion energy of CH<sub>x</sub>O<sub>y</sub> is equal to 117.2x-177.35y+ 422.5 joules per mol. Therefore, the H/C ratio x is fundamental: higher H<sub>2</sub> content induces higher energy per mass, but not per volume, because fuels tend to be gaseous.

- **Increasing the H/C ratio in fuel synthesis is called hydrogenation** and consumes energy. It can either source additional hydrogen from water vapor; directly from hydrogen gas (for example, from an H<sub>2</sub>-enriched biogas plant); or waste carbon in the form of CO<sub>2</sub> (such as coal-to-liquids plants); whereas
- **Reducing the H/C ratio in fuel synthesis is called dehydrogenation** and produces heat. It can either source additional carbon in the form of CO or CO<sub>2</sub> (from a methanation plant, for example); or waste H<sub>2</sub> in the form of water vapor (e.g. methane-to-liquid)

O<sub>2</sub> tends to reduce the molecule's heating value per mass, but helps to stabilize the fuel into liquid form (from methane to methanol).

Liquid fuels are critical for transport because of their high volumetric energy density (figure 144). Produced from clean/renewable electricity and potentially biomass, they can be certified as clean/renewable fuels and sold at a premium price. Unlike P2G projects, power-to-liquids does not need localized access to supply infrastructure gas.

Methanol is probably the most promising liquid synfuel, because of the easy synthesis reaction involved and its suitability as a substitute for gasoline. Liquid hydrocarbons such as gasoline have the best energy-carrier properties, but are much harder to synthesize, especially in a decentralized, small-scale manner.

**Figure 143: C-H-O model<sup>2</sup>**  
Distance relative to mole fraction

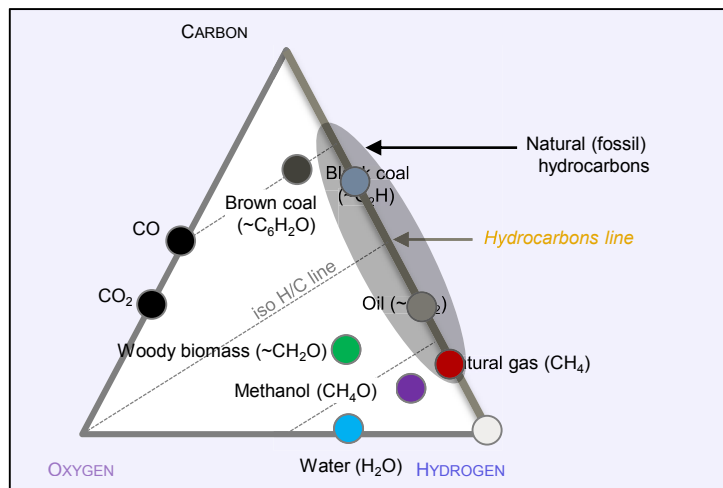

**Figure 144: Energy density comparison of transportation fuels**  
Indexed to gasoline = 1 (high heating value)

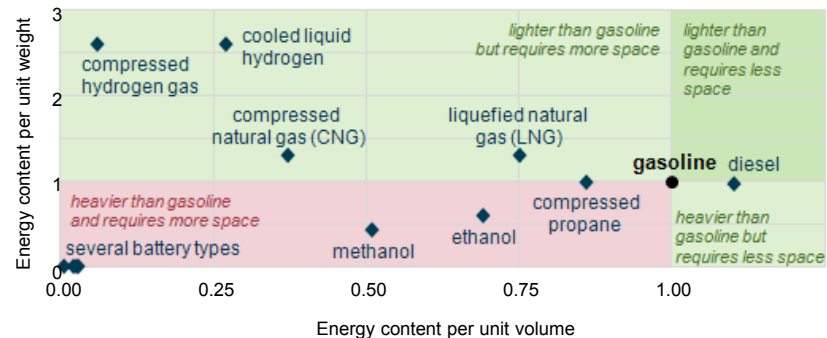

1. The volume of the storage tank is not taken into account and is larger for hydrogen than for liquid fuel. Electrical energy in kWh/e for lithium-ion battery. Long term goal of the US advanced battery consortium for electric vehicles. Assumes 20% tank-to-wheel efficiency for internal combustion engine, 45% for FC vehicles, 90% for electric vehicles. Source: INL (2011); Andrews (2011); EIA (2013).

## Methanol is a liquid fuel with a high H<sub>2</sub> content, making it an ideal H<sub>2</sub> carrier

Methanol<sup>1</sup> [CH<sub>3</sub>OH] contains more hydrogen atoms per volume than any other stable liquid under normal conditions, making it an ideal hydrogen carrier – methane and methanol are both carbon-based compounds with the highest possible H/C ratio, and both can be reacted in fuel cells. Methanol and methane economies are often referred to as relevant alternatives to a hydrogen economy for future energy systems. Methane is better adapted to densely populated regions, with a highly developed natural gas infrastructure, such as Germany; whereas methanol as an energy carrier has more support from China, but would necessitate to develop a dedicated infrastructure. Methanol is among the top-10 organic chemicals manufactured in the world, with 60 million tons consumed in 2012<sup>2</sup>. It is principally used to make plastics, solvents, and other petrochemicals.

**Direct energy use:** methanol as an alternative fuel to petroleum-based hydrocarbons is limited at the moment, but it could have great potential:

- **Internal combustion engines [ICE]:** methanol, like ethanol, contains about two-times less energy per volume than gasoline. But methanol has received much less attention in terms of R,D&D, investment and media interest than ethanol – the product of first-generation biofuel plants. Second-generation biofuels, from biomass gasification, will produce methanol more efficiently than ethanol. A blend of ethanol, methanol and petroleum is likely to be preferable to using any of these fuels on their own in ICE. Many countries allow limited methanol blending at the pump (3% in Europe). China is the leading user of methanol as a substitute for gasoline;
- **Domestic fuel** for heating and cooking: methanol burns more cleanly than gasoline and is safer for domestic use, because its flames can be extinguished with water; and
- **Power generation (fuel cells):** methanol fuel cells are commercially available at MW scale. They are similar to hydrogen fuel cells, but operate at lower efficiency. High-temperature, reformed-methanol fuel cells [RMFC] are being developed in an attempt to improve efficiency.

**Indirect energy use:** methanol is also converted into other liquid fuels (figure 145):

- **Dimethyl ether [DME] [CH<sub>3</sub>OCH<sub>3</sub>]** is generally produced from the simple dehydration of methanol  $2\text{CH}_3\text{OH} \rightarrow \text{CH}_3\text{OCH}_3 + \text{H}_2\text{O}$ . The process's energy consumption is marginal, so methanol plants usually serve both the DME and methanol markets. DME is a gas under normal conditions, but is very easy to liquefy under moderate pressurization, and is often considered a liquid fuel. It has excellent combustion properties making it a suitable substitute for liquefied petroleum gas or diesel in vehicles (moderate engine modification is needed). DME also increases gas-turbine efficiency; and
- **Formic Acid [HCOOH]** is the simplest acid, in liquid phase, under normal conditions. Like methanol, it is a good hydrogen carrier, compatible with formic-acid fuel cells. It is often produced from methanol, but can be directly synthesized from CO<sub>2</sub> and hydrogen.

**Figure 145: Chemical composition of some C-H-O syngas** (White = H, Black = C, Red = O)

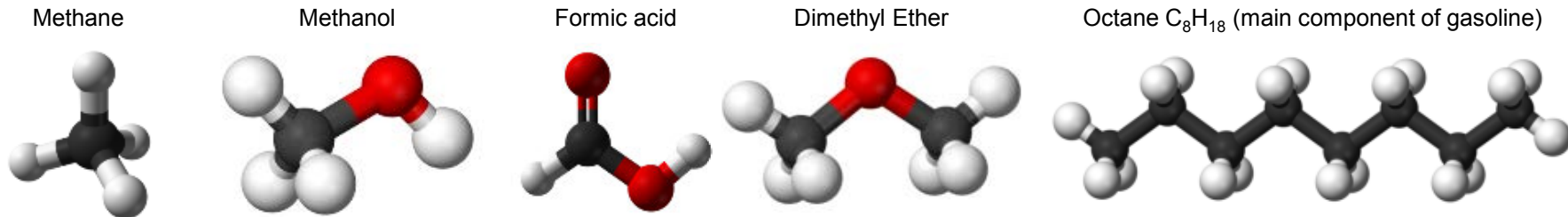

1. Methanol is the simplest alcohol. It is a light, volatile, colorless, flammable liquid. It is toxic if inhaled or absorbed (and often called denatured alcohol) as opposed to ethanol (drinking alcohol).

Source: 2IHS (2012).

# Methanol is the easiest liquid fuel to synthesize from CO<sub>2</sub> and H<sub>2</sub>

**Almost all commercially produced methanol comes from CO hydrogenation of syngas:**  $\text{CO} + 2\text{H}_2 \rightarrow \text{CH}_3\text{OH}$ . The required syngas H/C ratio of 4 is why the main source of syngas for methanol production is natural-gas reforming – a common industrial practice for over 80 years (figure 146).

**There are three promising, renewable-production pathways for methanol that utilize electrolyzers (power-to-methanol projects):**

**1. H<sub>2</sub> enrichment of syngas produced from biomass gasification**, which has a syngas H/C ratio of 2 (between 1.2 and 4 depending on the biomass source and gasification process). An electrolysis-assisted biomass-to-methanol gasification plant is one of the easiest ways to convert electricity into methanol, while maintaining carbon neutrality; and there are many synergies between the electrolyzer and the biomass plant (see Section 2.4). The first commercial projects are being developed: Blue Fuel Energy, in Canada, is planning to use abundant hydropower in British Columbia to integrate electrolysis into a Megamethanol plant.

New processes are being developed to synthesize methanol from any CO<sub>2</sub> source:

**2. Catalytic hydrogenation of CO<sub>2</sub> into methanol**, with H<sub>2</sub> from water electrolysis:  $\text{CO}_2 + 3\text{H}_2 \rightarrow \text{CH}_3\text{OH} + \text{H}_2\text{O}$ . The one-step thermochemical reaction is less efficient than CO hydrogenation, but quite similar in principle. It achieves the same efficiency as the Sabatier reaction for methanation, but requires different catalysts and higher pressures, making it slightly more expensive. The first commercial power-to-methanol plant using this process began operating in fourth-quarter of 2011. The 2.8 MW<sub>ch</sub> capacity plant, in Iceland, is the only one of its kind in the world producing liquid transport fuels from non-biological sources of renewable energy (figure 147).

**3. Direct, electrochemical reduction of CO<sub>2</sub> into methanol**, in a single-step, high-temperature co-electrolysis process (detailed in the following slides).

**Figure 146: CO hydrogenation reactor for methanol synthesis**

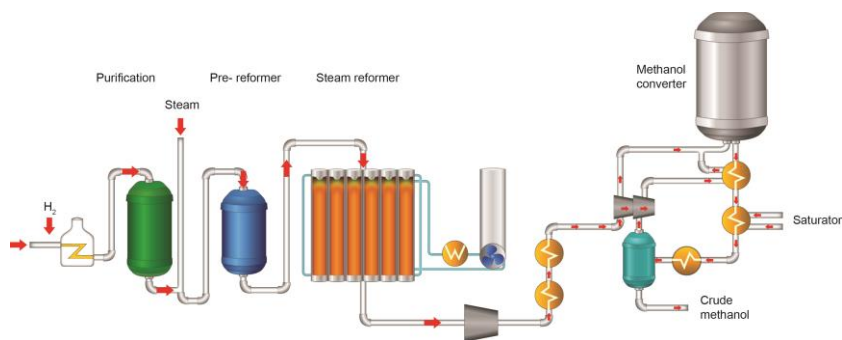

**Figure 147: George Olah renewable methanol plant, Svartsengi, Iceland**



The 2.8 MW<sub>ch</sub> Carbon Recycling International plant started operating in late 2011. It uses cheap geothermal electricity and CO<sub>2</sub>, sourced from the nearby HS Orka geothermal power plant. Methanol is sold as a renewable fuel under the name Vulcanol, to be mixed with gasoline. CRI plans to scale up the technology, with 30 MW<sub>ch</sub> plants across the world.

Note: Methanol prices: the spot-market price for methanol was \$52 /MWhch (or \$0.26 a litre) in February 2013. It is generally tracks crude-oil prices, at a discount (of around 20%), equivalent to about \$100 per barrel in energy content.

Source: Image courtesy of (left to right): Johnson Matthey Catalysts, Carbon Recycling International (2012).

## Liquid hydrocarbons can be synthesized from electricity, but would be economic only on a large scale

**Liquid hydrocarbons [HC] such as gasoline, diesel and jet fuel are the best performing energy carriers for transport. They have the highest volumetric energy density** of all chemicals ( $\sim 10$  kWh/liter), and are safe to handle relative to their energy content: each time a gasoline tank is refueled, 15 MW<sub>ch</sub> flows. Liquid HC are a mix of alkanes (C<sub>n</sub>H<sub>2n+2</sub>), with n ranging from 4 to 12, n=8 (octane) being the most common component in gasoline.

**Alkanes are long chains of -CH<sub>2</sub>- that are difficult to synthesize through CO<sub>2</sub> hydrogenation when n is higher than 1<sup>1</sup>. Liquid HC synthesis from syngas (Fischer-Tropsch [FT]) or methanol (methanol-to-gas [MtG]) is well known (see next slide).** Both are multi-stage catalytic processes, involving high capital costs and significant energy losses (63-74%<sub>HHV</sub> for hydrogen-to-liquids); and both must operate on a large scale to benefit from scaling effects (figure 149). Coal and natural gas are the main energy source for synthetic CH production, but neither is renewable nor carbon neutral. Biomass-to-liquids plants producing second-generation biofuels are in the commercial-scale demonstration phase.

**No power-to-liquids HC project has been built so far.** Lighter, oxygenated synfuel substitutes, such as methanol or dimethyl ether have been preferred for the first pilot projects. Potential pathways to convert electricity into liquid fuels are:

- **Methanol-mediated CO<sub>2</sub> hydrogenation into liquid HC**, with H<sub>2</sub> from electrolysis and CO<sub>2</sub> from any industrial source: and
- **Electrolysis-assisted biomass gasification, with FT or MtG process**, to enrich the syngas from biomass and raise the H/C ratio from 2 to the desired 4.

**These projects are viable only on a large scale, when the price difference between crude oil and the primary energy source used for synthesis is very wide.** Gonzales et al. (2011), estimates that biomass must cost at least \$70 /MWh<sub>ch</sub> less than crude oil to make it competitive. Cheap electricity used to supply hydrogen could improve these economics. In that context, the Blechner Center at Ben Gurion University of the Negev in Israel recently announced the development of novel specially tailored catalysts and catalytic processes that would be ready for large-scale demonstration after successful bench experiments<sup>2</sup>.

**Figure 148: Liquid fuel prices per energy content**

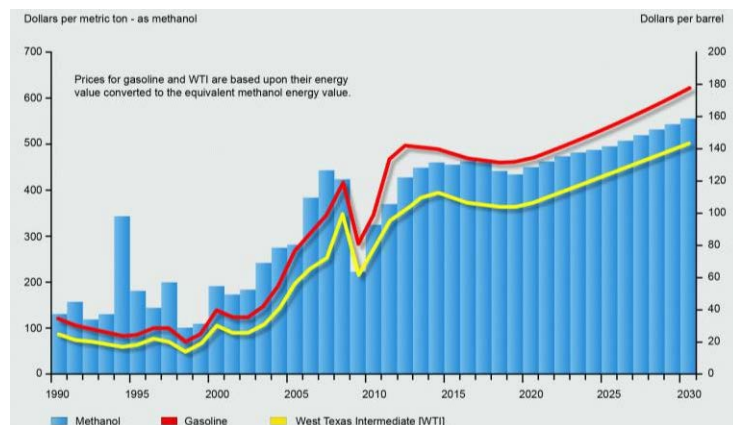

**Figure 149: SASOL-Chevron Fischer-Tropsch reactor**



1. if n=1, C<sub>n</sub>H<sub>2n+2</sub> = CH<sub>4</sub>: this is the methanation process; 2Based on information provided by Prof. Moti Herskowitz, Director of the Blechner Center for Industrial Catalysis and Process Development  
Source: IHS (2012); image courtesy of: SASOL-Chevron.

# Box 6: Fischer-Tropsch vs. methanol-to-gasoline processes for synfuel production

**Similarities:** The same simplified reaction takes place: hydrogenation of  $nC + (n+1)H_2 \rightarrow C_nH_{2n+2}$ , with n between 5 and 20. Both pathways involve exothermic catalytic processes, requiring around six different high-pressure reactors (up to 70 bar) in series. To produce liquids rather than gaseous fuels ( $n > 4$ ), reactor temperature is lower than that of methanation ( $n = 4$ ), causing a slower reaction rate. Consequently, several intermediary steps are required to select the desired molecules from the wide spectrum synthesized. Both technologies are commercially available and no clear economic preferences have yet been established for either. Both have high capital costs and significant energy penalties. The energy efficiency of hydrogen-to-liquids ranges from 63% to 74%.

**Differences:** The FT process produces mainly diesels, while methanol-to-gasoline [MtG] delivers high-quality gasoline. The FT reaction yields a wider range of hydrocarbons, including unwanted wax, requiring additional refining processes to produce the desired end-product. MtG is more selective, producing only light hydrocarbons ( $n < 9$ ). If the initial feedstock is a  $CO_2 + H_2$  mix, MtG is preferable to FT because it avoids the reverse water-gas shift of  $CO_2$  into CO.

## FISCHER-TROPSCH (FT)

### Process

1. Catalytic hydrogenation of CO into high fractions (~six reactors)  
 $nCO + (2n + 1)H_2 \rightarrow C_nH_{2n+2} + nH_2O, n > 21$
2. Wax hydrocracking into the desired chain length

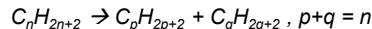

**Status:** FT was invented in 1923 and used in Germany during World War 2 for liquid fuels production from coal. It is now a mature technology: South Africa's Sasol produces 140,000 barrels per day (10 GWch) of FT synfuels from coal; and two commercial-scale, FT gas-to-liquids plants have been built in Qatar since 2005. Other FT technology vendors are ExxonMobil and Shell. No power-to-liquids HC project using FT has been built

## METHANOL-TO-GASOLINE [MtG]

### Process

1. CO or  $CO_2$  hydrogenation for methanol synthesis (one reactor needed)  
 $CO + 2H_2 \rightarrow CH_3OH$ , or  $CO_2 + 3H_2 \rightarrow CH_3OH + H_2O$
2. Dehydration of methanol (~six reactors)

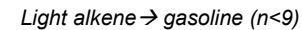
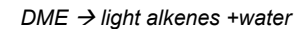
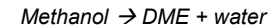

**Status:** MtG, also known as "Mobil process", was invented and first operated by Mobil in 1985. Today, about 35,000 barrels per day (2.5GW<sub>ch</sub>) are produced.

Figure 150: Synthetic liquid hydrocarbon pathways

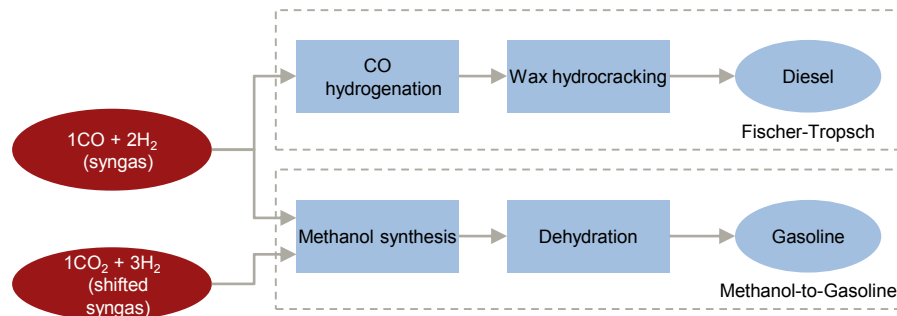

## Solid-oxide electrolyzers are the most efficient way to produce syngas, but are not commercially available

**Syngas ( $\text{CO}+\text{H}_2$ ) is a highly valuable gas mixture in many applications** and the best feedstock for H-C-O synfuels synthesis. Efficient ways to produce syngas have been examined for decades: **the most energy efficient process involves co-electrolysis of  $\text{CO}_2$  and  $\text{H}_2\text{O}$  vapor at high temperature in solid oxide electrolyzer cells [SOEC] (figure 151).**

**Figure 152 shows how a SOEC stack, operated at a temperature of  $800^\circ\text{C}$ , naturally electrolyzes  $\text{CO}_2$  and  $\text{H}_2\text{O}$  at the same time, with a theoretical efficiency of 100%.** By varying the ratio of the  $\text{CO}_2/\text{H}_2\text{O}$  input, syngas with the desired H/C ratio can be produced – an optimal ratio of 4 for liquid synfuel synthesis (methanol, dimethyl ether or Fischer-Tropsch). In practice, state-of-the-art SOEC systems have reached 89% efficiency, because of energy lost in the balance of plant components.

**The problem for SOEC lies neither with its efficiency, nor its capital cost, but with its technical maturity. For commercial viability, reactor membrane lifetime must improve significantly to sustain high temperatures over long periods.** The largest operating pilot project is only about 18 kWe. R&D efforts are intensifying and a breakthrough in membrane materials would greatly improve the outlook for power-to-synfuels, and H<sub>2</sub>-based electricity-storage systems, as SOECs operated in reverse mode can function as fuel cells.

Figure 151: SOEC in co-electrolysis mode<sup>2</sup>

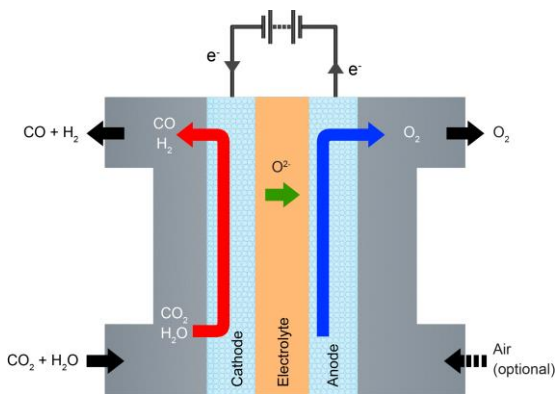
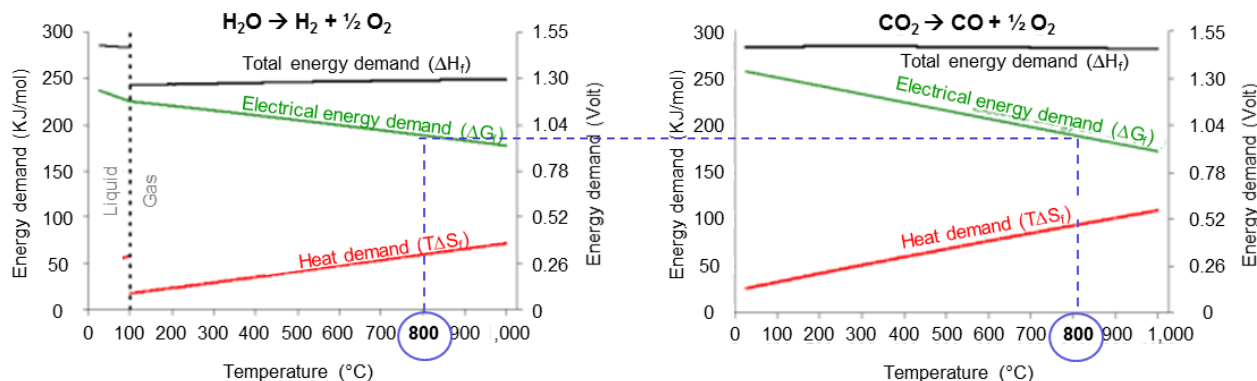

Figure 152: Thermodynamics<sup>2</sup> of SOEC in co-electrolysis mode



At high temperature, a great share of total energy demand for electrolysis (black line) can be supplied in the form of heat (red line) instead of electrical energy (green line). Heat energy is of lower value (exergy) than electricity, and can partially be supplied by unavoidable resistive losses of the electric circuits. By applying the exact thermo-neutral potential at the electrode (corresponding to the black line), resistive losses precisely match heat demand (called autothermal mode), and electrolysis efficiency is 100%, in theory. At  $800^\circ\text{C}$  precisely<sup>1</sup>, autothermal mode can be reached for  $\text{CO}_2$  and for  $\text{H}_2\text{O}$  electrolysis at the same time, so that both reactions can occur with 100% efficiency.

1. For atmospheric pressure. One temperature of co-electrolysis exists for each pressure.  
Source: 2DTU (2012).

## Direct Synfuel SOECs convert electricity into methane or methanol in a one-step process, within the electrolyzer stack, allowing flexible and efficient synfuel production at any scale

As long as SOECs are maintained at high temperature, with sufficient insulation, they can produce high-temperature and -pressure syngas in a very flexible manner. Processes are being developed to convert this reactive syngas into simple synfuels, such as methane or methanol, in a single electrolyzer stack (figure 153), similar in principle to the thermochemical hydrogenation of CO.

Nuclear electricity stakeholders, such as Areva and Idaho National Laboratory, are testing a direct synfuel SOEC system that will yield methane directly from a SOEC electrolyzer. The long-term aim is to produce synfuels from cheap, baseload nuclear electricity, while recycling excess heat from the nuclear reactor to supply the endothermic heat demand of SOEC.

By contrast, Topsoe Fuel Cell and the Technical University of Denmark are investigating direct methanol SOEC, used in intermittent loading, to monetize temporary excesses of electricity generation from Danish wind farms. The main advantage of electrolyzers in small applications is that they derive limited benefits from up-scaling relative to thermochemical reactors. It allows decentralized, small-scale synfuel plants to be built at much lower costs than any existing alternative. Decentralized options are highly attractive in hydrogen-based electricity-recycling projects, because high volumes of low-cost electricity are seldom available from the grid, and excess electricity can be utilized directly at the solar or photovoltaic plant. Figure 154 depicts an interesting decentralized utilization of direct methanol SOEC, combined with a small-scale biofuels plant: it optimizes fuel production of a maize field combined with a windmill. The plant produces renewable synthetic ethanol and methanol, which can be sold at premium price under renewable-fuel standards.

Figure 153: Direct synfuel SOEC stack

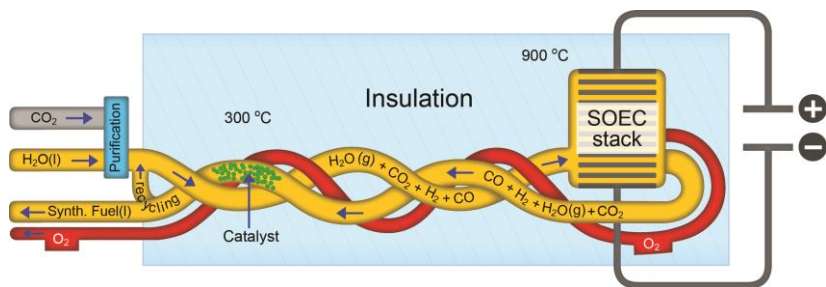
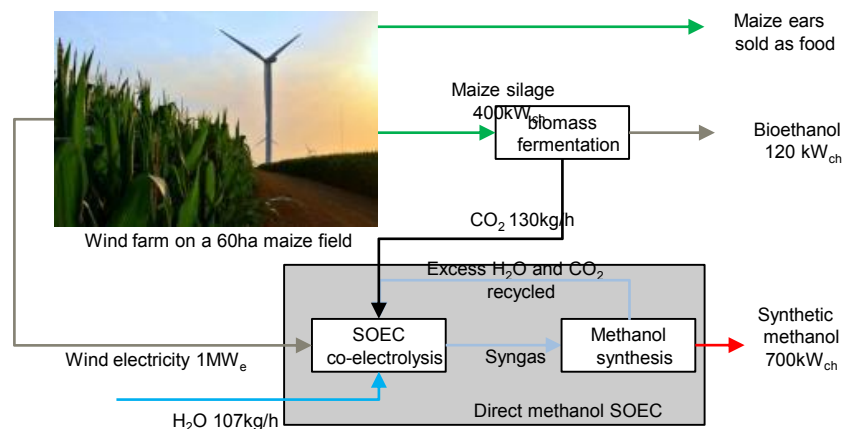

Figure 154: Direct methanol SOEC coupled with first generation bioethanol plant for land use optimization



Note: Figures are orders of magnitude.

Source: Risø National Laboratory for Sustainable Energy; Technical University of Denmark; A.T. Kearney Energy Transition Institute analysis.

## Sources: section 2.5

Andrew (2011), *“Re-envisioning the role of hydrogen in a sustainable energy economy”*, Andrew Reed

Energy Information Administration – EIA (2013), *“Today in Energy”*,  
<http://www.eia.gov/todayinenergy/detail.cfm?id=9991>

Gonzales et al. (2011), *“Process comparison of biomass-to-liquid (BtL) routes Fischer-Tropsch synthesis and methanol to gasoline”*, Maria Iglesias Gonzalez, Régis Edzang, Georg Schaub, Karlsruhe Institute of Technology

IHS (2012), *“Global Methanol Market Review”*

Idaho National Laboratory – INL (2011), *“Electrolysis For Synthetic Fuel Production”*, Carl Stoots, Presentation at the Topsoe Catalysis Forum

Saito et al. (2000), *“Advances in joint research between NIRE and RITE for developing a novel technology for methanol synthesis from CO<sub>2</sub> and H<sub>2</sub>”*, Masahiro Saito, Masami Takeuchi, Tadahiro Fujitani, Jamil Toyir, Shengcheng Luo, Jingang Wu, Hirotaka Mabuse, Kenji Ushikoshi, Kozo Mori, Taiki Watanabe, Applied Organometallic Chemistry, vol. 14, pp. 763-772.

Technical University of Denmark – DTU (2012), *“Solid Oxide Electrolysis Cells”*, Sune D Ebbesen, Presentation at the symposium Water electrolysis and hydrogen as part of the future Renewable Energy System

Wang et al. (2011), *“Recent advances in catalytic hydrogenation of carbon dioxide”*, Wei Wang, Shengping Wang, Xinbin Ma and Jinlong Gong, Chemical Society Review, vol. 40, pp. 3703-3727

## 2.6 - Hydrogen-to-mobility: fuel cell & internal combustion engine



## Summary & key findings: section 2.6

- 1. Hydrogen is a vital molecule for mobility** because its chemical energy content is contained in most of the fuels that powers our vehicles:
  - Fossil fuels, where it is widely used for refining processes (50% of all hydrogen consumed globally);
  - Synthetic fuels, where it is used as a feedstock for biofuels, electrolytic synfuels and ammonia fuels; and
  - Direct hydrogen fuels in H<sub>2</sub> form, for hydrogen-powered vehicles (the focus of the present section).
- 2. Hydrogen-powered road vehicles have been proclaimed the future of mobility since the 1970s**, but have regularly fallen in and out of public favor and continue to face various economic and technology barriers. Today, only 200 H<sub>2</sub> refueling stations are in operation, 74 of which source hydrogen from electricity (~6 MW). Well-funded, high-profile public R&D programs are in place to promote hydrogen mobility, motivated both by growing environmental concerns (GHG and local pollution) and the challenging geopolitics and economics of supplying fossil fuels (energy security and crude oil & gas trade imbalances).
- 3. One of the main impediments to hydrogen mobility is the “chicken and egg” dilemma of H<sub>2</sub> infrastructure** (the lack of fueling stations discourage fuel-cell electric vehicle [FCEV] development and vice versa). It is now generally accepted that government support will initially be needed to make H<sub>2</sub>-powered mobility a reality.
- 4. Another problem affecting all types of hydrogen vehicle is the storage tank**, which, at present, is inefficient and uses up a large amount of space. The best option at present are 700 bar cylinders, which have a range of 500 km and take fewer than 5 minutes to refill; however, in order to achieve a refueling time of 5 minutes, the hydrogen must be precooled to -40°C, which incurs significant costs (in compression equipment and tank manufacturing) and energy requirements are high.
- 5. Three types of hydrogen-powered vehicles are in competition:** fuel-cell vehicles, hydrogen internal combustion engine vehicles [H<sub>2</sub>ICE], and hydrogen-enriched compressed natural gas vehicles [HCNG]. Prospects for commercial deployment of any of these vehicles are highly uncertain, and depend both on the cost of the technology and that of the hydrogen delivered. As a result, market opportunities for hydrogen produced electrolytically for mobility are even more hypothetical. In general, bus fleets and forklift trucks are likely to be the first niche markets for (electrolytic) hydrogen mobility.
  - **FCEVs'** comparative advantage is the energy efficiency of the engine. As it is not limited by Carnot heat engine efficiency, it can achieve twice the efficiency of internal combustion engine vehicles. Other advantages include quietness of driving, zero tailpipe emissions and the aptitude of FCEVs to regenerative braking. Drawbacks include the high cost and relatively short lifespan of fuel-cell systems. Serial production of FCEV is expected to begin in 2015, with a 600 km-range vehicle costing about \$50,000 (a figure based on a production volume target of 200,000 vehicles);
  - **H<sub>2</sub>ICE**, which adapts a well known engine technology to keep down vehicle-manufacturing costs, has lost momentum compared with FCEVs due to lower hydrogen fuel efficiency; and
  - **HCNG** vehicles may provide a temporary solution to the hydrogen infrastructure chicken-and-egg dilemma: About 14.8 million compressed natural gas vehicles are deployed worldwide and could be fuelled with hydrogen/natural gas blends (ideally at 20vol.% hydrogen) with minimal engine tuning, for cleaner driving and improved motor performance.

# Hydrogen is a vital molecule for mobility

The role of hydrogen in mobility extends well beyond its use as pure hydrogen fuel (figure 155). The following section focuses on vehicles powered directly by pure hydrogen fuels ( $H_2$  in molecular form). Nevertheless, there are two other indirect ways in which hydrogen can be used for mobility:

- **Pathway for fossil fuel:** Hydrogen is used to improve the performance of refined products. Presently, around 50% of all hydrogen produced is utilized in refineries either to desulfurize sour crude or to break down heavy crude into more useful, smaller chains, such as gasoline (see Section 2.7 for further details)
- **Pathway for synthetic fuels:** Hydrogen can be used to synthesize fuels that are not fossil-based, but have exactly the same chemical properties. Hydrogen is combined with carbon to produce H-C-O synfuels (see Section 2.5) or combined with nitrogen to produce ammonia (see Section 2.7).

Figure 155: The role of hydrogen in mobility

Present

Future? 

## FOSSIL FUELS (SECTION 2.7)



### Diesel and gasoline

- Increase hydrogen / carbon [H/C] ratio of heavy oil fractions
  - Desulfurization (more stringent regulation)
- Natural gas vehicles [NGV]
- Reduce local pollution and increase performance with hydrogen blending (hydrogen compressed natural gas fuel)

## SYNTHETIC FUELS (SECTION 2.4, 2.5 & 2.7)



### Biofuels

- Enrich biofuel plant with hydrogen to maximize biomass yield and thereby land use

### H-C-O synfuels

- Fix hydrogen with  $CO_2$  to synthesize methane, methanol, dimethyl ether, gasoline...

### Ammonia fuels

- Fix hydrogen with nitrogen and use ammonia as a fuel

## PURE HYDROGEN FUEL (SECTION 2.6)



### Pure hydrogen carrier<sup>1</sup>

- Use hydrogen to produce electricity in fuel cell electric vehicles [FCEV]
- Use hydrogen fuel cell in battery electric vehicles [BEV] as a range extender

1. Hydrogen internal Combustion engine [H2ICE] that uses a traditional ICE, modified to burn hydrogen instead of conventional gasoline, has lost momentum compared with FCEV and is not mentioned in this slide.

Source: A.T. Kearney Energy Transition Institute analysis.

# In the last 230 years, H<sub>2</sub> has been used in all types of land, water and air transportation

One of the first elements formed in the universe, hydrogen started its journey as a mobility agent in 1783, when the Frenchman Jacques Charles invented the hydrogen balloon. In 1839, the first fuel cell was invented and, in 1863, the first hydrogen-powered internal combustion engine. In 1895, Count Zeppelin patented the hydrogen air ship (the Zeppelin) and, by 1910, commercial Zeppelin flights had started. Before the Hindenburg accident, in 1937, wrongly blamed on hydrogen until 1997, there were regular flights from Europe to the US and Brazil. In 1926, Norge, the first airship to fly over the North Pole, used hydrogen as a lifting gas.

In 1958, NASA started researching liquid hydrogen and liquid oxygen fueled rockets, pioneering many other hydrogen technologies in the process. The same year also produced the first fuel-cell-electric vehicle (tractor D12). In 1964, the first fuel-cell-powered underwater research vessel was built. Two years later, General Motors introduced the proton exchange membrane fuel-cell van. In 1998, research started in Germany to build the first fuel-cell-powered submarine.

In 2003, the US allocated \$1.2 billion to R&D in hydrogen technologies (\$350 million of which was earmarked for transportation). The same year, the first public hydrogen filling station was opened in Reykjavik, Iceland. In 2008, Honda began leasing the FCX Clarity fuel-cell electric vehicle.

The story of hydrogen in the transportation sector continues to evolve: the first commercially available fuel-cell-electric vehicle has been launched in 2013 (Hyundai's ix35). Also this year, Ford, Nissan and Daimler signed an agreement to develop fuel-cell electric vehicle technology, which could bring these cars to the market by 2017. BMW and Toyota have also signed an agreement to collaborate on fuel-cell development for vehicles.

Figure 156: Timeline for hydrogen in the transportation sector

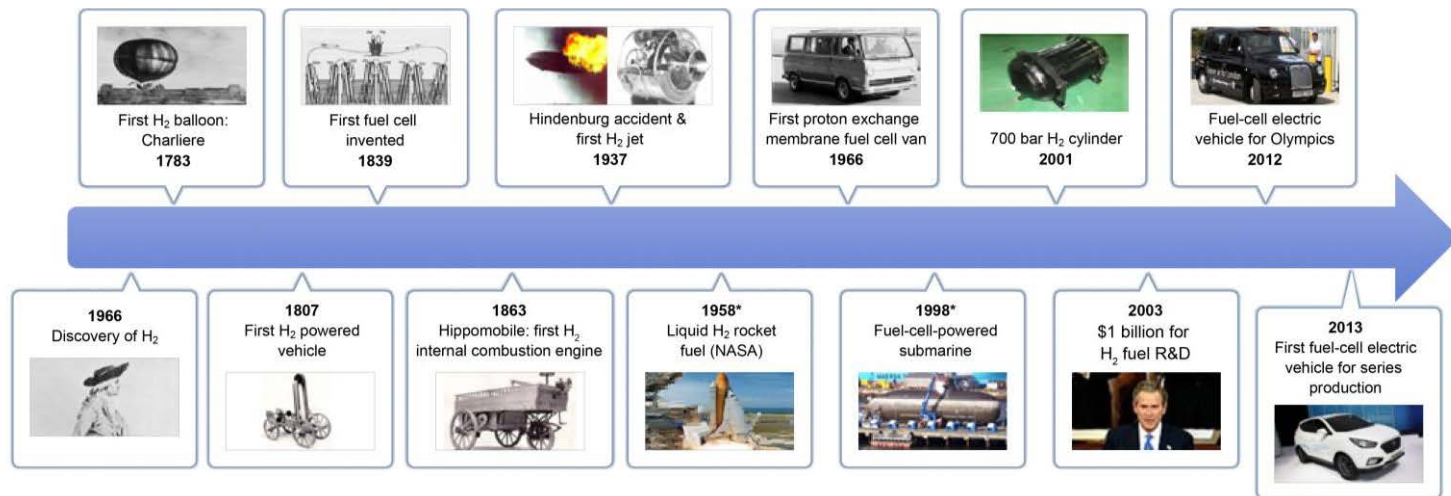

Note: Start of research.

Source: FuelCellToday (2012a); NYERSDA.

# Since the 1970s, H<sub>2</sub>-powered road vehicles have been proclaimed the future of mobility

Using hydrogen as a fuel for road transportation is an environmentally attractive concept that has fallen in and out of public favor over the last few decades. The hydrogen-economy buzz of the 1970s fizzled away in the face of onerous cost and technology barriers. Interest was rekindled in the 2000s, but ended as the global economy collapsed and cheaper energy sources were discovered (e.g. shale gas). **One of the main problem has always been the need for – on the one hand – huge and risky investments in engine and fuel-cell technology, and – on the other hand – the simultaneous development of fuel-dispensing infrastructure (the chicken-and-egg dilemma).** Decentralized electrolyzers could provide a solution – manufacturing H<sub>2</sub> at fueling stations; this would avoid the need for centralized H<sub>2</sub> plants and expensive distribution infrastructure. But hydrogen fuelling stations would still be needed. Only 202 are in operation today (figure 158). Of these, 74 source hydrogen from electrolysis and have a combined production capacity of less than 6MW<sub>ch</sub> of electrolytic hydrogen (more details in Section 2.8).

**Significant technological developments, matched by social and political commitment, are required to make hydrogen a commercial transportation fuel. In recent years, considerable funding has been allocated to hydrogen R,D&D with a clear focus on transportation (figure 157).** The German National Innovation Program [NIP] plans to spend close to €1.4 billion on hydrogen R,D&D between 2007 and 2016. In the past five years, the United States' annual expenditure has averaged around \$160 million and the European Commission has allocated about \$600 million to research and demonstration projects. Funding for hydrogen-related,R,D&D by the Japanese New Energy and Industrial Technology Development Organization was about \$100 million in 2011. South Korea has provided hydrogen R,D&D with some \$600 million over the past 10 years.

Figure 157: Public R&D in fuel cells, 2000-2010<sup>2</sup>  
\$ million

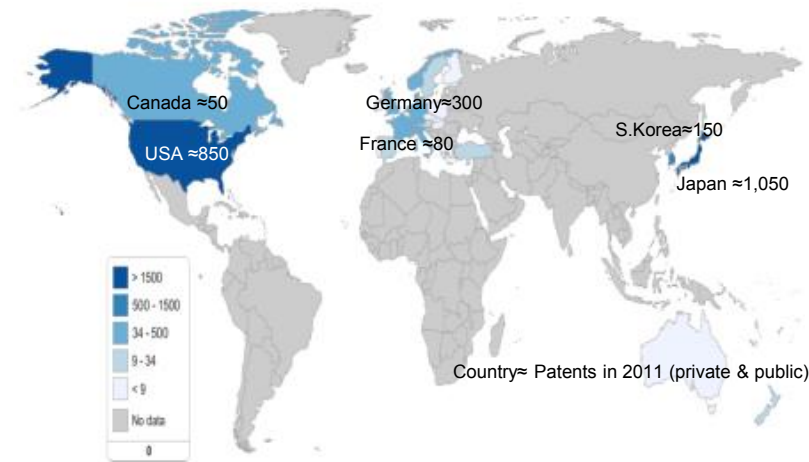
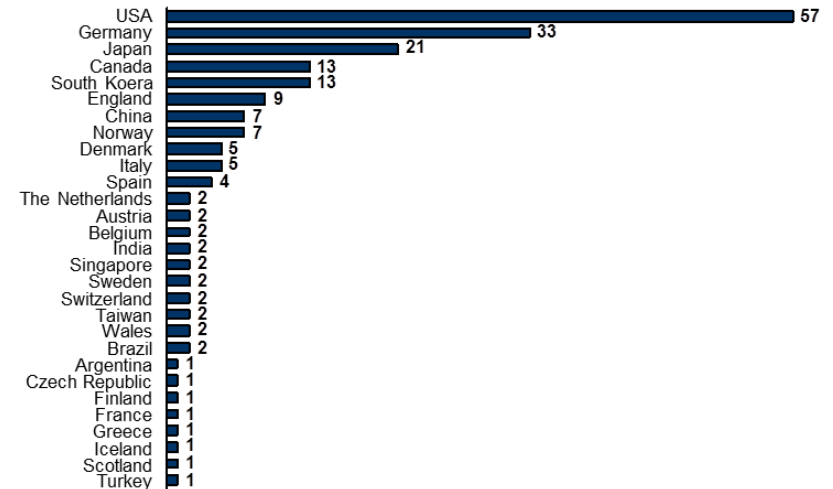

Figure 158: Operational number of H<sub>2</sub> fueling stations, as of April 2013<sup>1</sup>



Note: Refueling stations for road transportation only, excluding those built for the sole purpose of refueling forklifts, boats, or scooters.  
Source: 1 US DoE Hydrogen Analysis Resource Center; 2 FuelCellToday (2012a).

# Environmental and geopolitical economic factors are encouraging the use of hydrogen in mobility but there is a long way to go

There are three types of hydrogen-powered vehicle (figure 159):

- **Fuel cell electric vehicles [FCEV]**, in which chemical energy in hydrogen is converted into electrical energy by fuel cells, and then into mechanical energy by an electric motor. Hybrid electric vehicles with fuel cells serving as range extenders are also being considered;
- **Hydrogen internal combustion engine vehicles [H2ICE]**, in which hydrogen is burned in the same way as any other fuel, in a specially designed thermal engine; and
- **Hydrogen-enriched compressed natural gas vehicles [HCNG]**, in which hydrogen is used as an additive to natural gas in commercial CNG vehicles.

The three main drivers for hydrogen mobility are:

- **Geopolitical economics** (trade imbalance and energy security): energy-rich and energy-deficient countries want to reduce local fossil-fuel consumption – the former to increase energy-export revenues, the latter to reduce energy imports.
- **Climate**: Mounting political and public pressure to reduce greenhouse gas emissions could encourage a more rapid development of electrolytic hydrogen than would be achieved if the sector's growth were solely motivated by constraints in the availability of fossil fuels.
- **Local pollution and noise** are growing concerns in densely populated urban areas. Tailpipe emissions of FCEVs are limited to water vapor, and driving is noiseless.

The concept of hydrogen as a fuel to power our vehicles sounds attractive. However, it requires the development of a network of refueling stations. Numerous barriers – relating to technology, cost and safety – must be removed before the concept can be commercialized.

**Figure 159: From left to right, Honda FCX clarity (FCEV), BMW Hydrogen 7 (H2ICE) and HCNG dispenser fuelling a HCNG Bus**



# Hydrogen-powered vehicles have better lifecycle efficiency and lower CO<sub>2</sub> emissions than conventional gasoline/diesel vehicles, but only when hydrogen is produced decarbonized energy sources

First, on conducting a well-to-wheels energy analysis (figure 160) for various available engine technologies, electric vehicles [EV] appear to have by far the best energy performance – though they cannot compete with H<sub>2</sub> or hydrocarbon fuels for autonomy or recharge time. Second, **hydrogen vehicles have a superior energy efficiency and lifecycle CO<sub>2</sub> footprint to conventional gasoline vehicles, provided energy used for electrolysis is sourced from renewables or nuclear.** Otherwise, lifecycle energy efficiency and CO<sub>2</sub> emissions worsen to unsustainable levels. **The energy and environmental performance of hydrogen-powered vehicles is even more sensitive to the carbon content of electricity sources than battery vehicles are.** Finally, hydrogen internal combustion engines [H2ICE] and hydrogen compressed natural gas [HCNG] engines generally perform slightly better than gasoline engines.

**Figure 160: Well-to-wheel energy efficiency & lifecycle CO<sub>2</sub> emissions comparison for different type of engines**

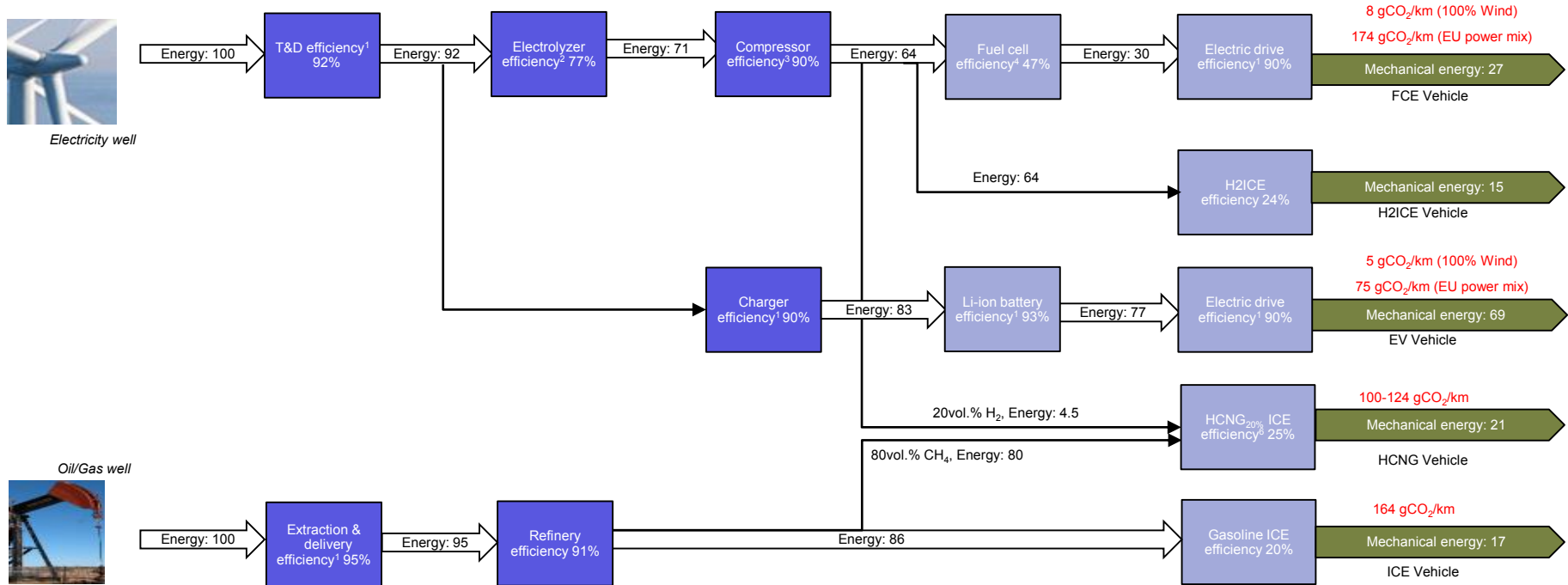

Note: Conventional ICE reference vehicle consumes 7 L/100 km of gasoline; 2Best commercial models refers to Section 2.1; 3Refers to Section 2.2; 4Mean of U.S. DoE range: 42-53%; 6Equivalent to diesel engine.

Source: CO<sub>2</sub> emission in gCO<sub>2</sub> equivalent per km comes from DENA (2012); energy efficiencies are from A.T. Kearney Energy Transition Institute analysis, based on 1Eaves et al.

## At present, storage tanks are expensive, preventing the large-scale commercialization of hydrogen cars

**One of the main challenges of using electrolytic hydrogen as a fuel for transportation is finding a suitable on-board storage device.** This needs to be safe, reliable, compact, durable (lifetime of 1,500 cycles), cost-efficient and able to receive and release  $H_2$  rapidly. High energy content per unit of volume is of prime importance for mobility, but, at present, stored hydrogen contains less energy per volume than conventional fuels, whichever storage technology is used.

As explained in Section 2.2, hydrogen can be stored in three states: gaseous, liquid and in metal hydrides. Metal hydrides are too heavy and take too long to recharge. Liquefied  $H_2$  boils off too rapidly for use in personal vehicles, although it could be used in buses. High-pressure gaseous hydrogen storage cylinders, made entirely of composite materials in order to withstand very high pressures, are the best option at present. **700 bar cylinders are the most suitable technology for long-range hydrogen-powered vehicles**, although they are bulkier and heavier than traditional gasoline/diesel tanks (figure 161).

**An onboard storage tank with a pressure rating of 700 bar and a capacity of 5.6 kilograms currently costs around \$3,500<sup>1</sup>.** However, progress in developing better storage technology for hydrogen is slow. In 2009, the US DoE cut its 2015 commercialization targets for gravimetric density by 38%. This occurred partly because progress had fallen behind schedule and partly because improvements in fuel-cell technology have reduced storage needs and, as a result, gravimetric density requirements.

**Many research projects are under way, but most of them are still in the experimental stage.** An interesting possibility could be to combine high-pressure hydrogen with liquid hydrogen to extend vehicle range, reduce boil-off and speed up fueling<sup>2</sup>. Another is to use solid, hollow, glass microspheres, under 0.1mm in diameter, which can behave like a liquid (as sand does) at ambient temperature and can easily be placed in a fuel tank at a refueling station. The storage process consists of three stages: filling the hollow glass with hydrogen, at around 300°C & 700 bar; cooling the gas to ambient temperature; and re-heating it to 300°C to release hydrogen (figure 162).

**Figure 161: Comparison of weight and volume of energy storage tanks for a 500 km range personal vehicle<sup>3</sup>**

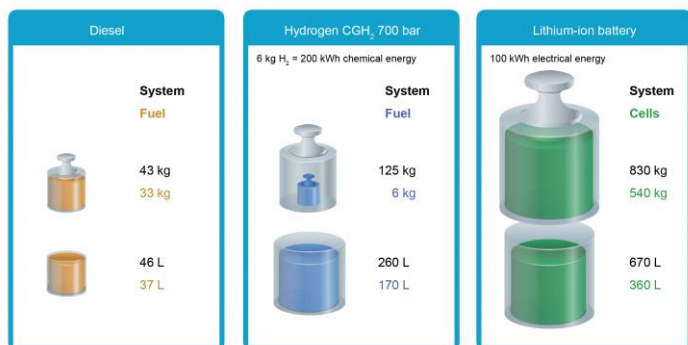

**Figure 162: Hydrogen-filled hollow glass microsphere<sup>4</sup>**

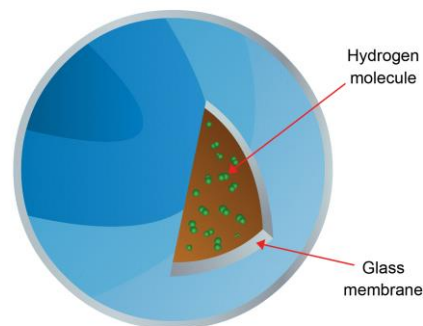

1. Note: 2. BMW is promoting the high-pressure liquid hydrogen concept, also known as cryo-compressed hydrogen, in collaboration with Linde and the Lawrence Livermore National Laboratory [LLNL] (2013). Source: 1. Greene (2013); 3Daimler AG (2013); 4Shelby et al. (2008).

# Fuel cell electric vehicles remain in the development phase despite involvement of the large automakers

**Fuel cell electric vehicles [FCEV] utilize fuel-cell technology, whereby chemical energy in hydrogen is converted directly into electrical energy.** As no combustion takes place, FCEVs have zero tailpipe emissions except water vapor. Moreover, as fuel cells have no moving parts, FCEVs are as quiet as electric vehicles and vibrate less. FCEVs usually incorporate a short-range battery to recover energy from braking – a feature shared with hybrid electric vehicles (figure 163). The first commercial FCEVs should have a 600 km range, refueling should take five minutes and the typical cost of a vehicle should be around \$50,000<sup>2</sup>.

**This technology has been developing slower than initially expected, notably due to the chicken and egg dilemma** (lack of fueling stations discouraging FCEV development and vice versa). As with other low-emissions vehicles, it is now widely recognized that financial public support will initially be needed to make FCEVs a commercial reality. The roll-out of hydrogen infrastructure will need to be carefully coordinated. In addition to an expansion of H<sub>2</sub>-distribution infrastructure, FCEVs would benefit from the reduction in FC costs that should arise from the scaling effect; and from further progress on hydrogen storage.

**The commercialization of FCEVs is, nonetheless, slowly accelerating: almost every large automaker is developing FCEVs, albeit cautiously.** There are more than 650 on-road demonstration FCEVs<sup>1</sup> (including buses) worldwide. Automobile manufacturers including Honda, Daimler, GM have made a limited number of production FCEVs available for lease. Hyundai recently announced the first mass production of a FCEV; it will produce 1,000 units per year of its ix35 model in 2015 (figure 164). Cities including London, Copenhagen, Berlin, Los Angeles have launched FC-based taxis and buses for demonstrative purposes. FCs are being showcased in off-road utility vehicles such as locomotives for mining, landscaping trucks and tractors. **In 2011, there were more than 3,000 FC powered forklifts<sup>2</sup>** (either deployed or on order) in the US. Prototype FC two-wheelers are also being developed. Suzuki's Burgman scooter became the first FC vehicle to receive Whole Vehicle Type Approval [WVTA] from the UK Department of Transport in 2011.

**Figure 163: Basic circuits in a fuel-cell electric vehicle<sup>4</sup>**

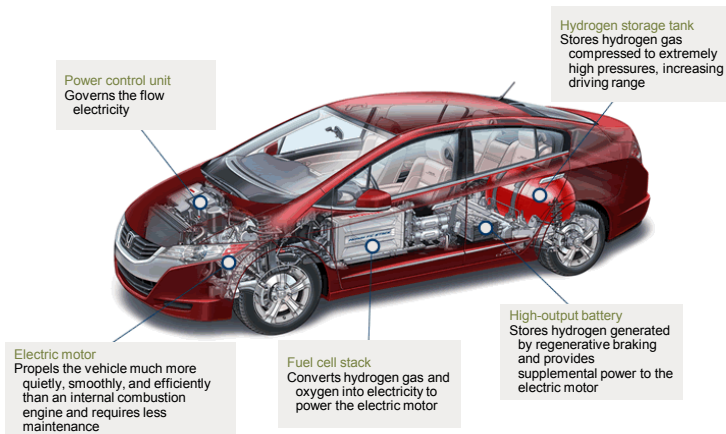

**Figure 164: Hyundai ix35 fuel-cell electric vehicle<sup>5</sup>**



## PEM is the most suitable type of fuel cell for fuel-cell-electric vehicles, but durability and manufacturing cost remain significant impediments

The proton exchange membrane fuel cell [PEMFC] is the most widely used in fuel cells for transportation (see Section 2.2). Their relatively low operating temperature (85°C), high power density, flexibility for quick start-up and variable output (in response to demand) and ability to operate in any orientation – positioned vertically or horizontally, for instance – make them an ideal power generator for automobiles. **The two biggest concerns for PEMFCs are limited lifespan and high manufacturing price per kW:**

- **Lifespan** (figure 165): to compete with internal combustion engine [ICE] vehicles, the US DoE says PEMFCs should be able to operate for 5,000 hours (equivalent to 150,000 miles) with less than 7% degradation, and it has set this as a target for 2015. Improvements have been made over the years, yet lifespan remains nowhere near this target (figure 165). Experimental data indicate a lifespan of around 2,500 hours (75,000 miles). Catalysts are the main cause of the rapid decline; they degrade as a result of spikes in currents and poisoning from contaminants such as chloride ions. Even though fuel cell electric vehicles [FCEVs] can now start up in sub-freezing temperatures, water management – the fuel cell's membrane must be kept hydrated to avoid the build-up of resistance and membrane decay – still needs to improve for durability to increase.
- **System cost** (figure 166): the DoE says the cost of FCEVs (when mass-produced<sup>1</sup>) needs to fall to \$30 /kW to compete with conventional ICE vehicles, and has set this as a target for 2017. The price for state-of-the-art technology in for 2012, extrapolated for mass production using current technology, is calculated at \$47 /kW. The price of PEMs for mobile purposes is much lower than that for stationary purposes (\$800 /kW in 2020), which are designed with a much longer lifespan (10,000 h today and 50,000 h in 2020), and involve a more complex balance of plant.

Figure 165: Mobile proton exchange membrane lifetime

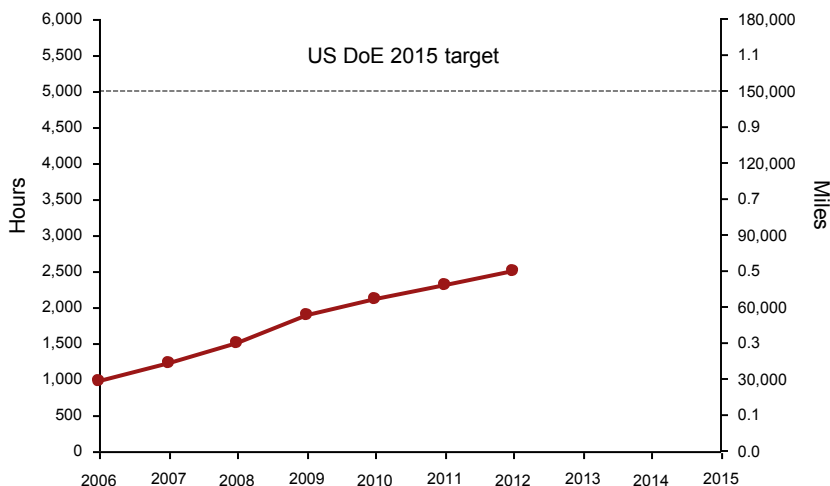
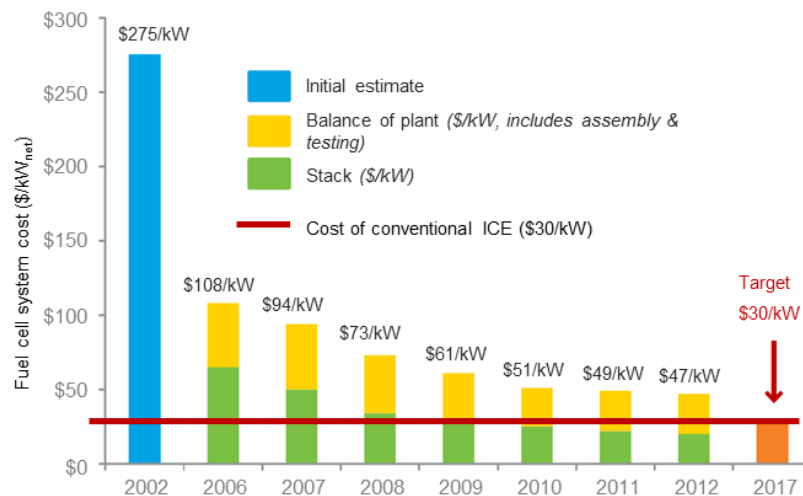

Figure 166: Mobile fuel cell system costs: target at a production rate of 500,000 units per year



1. 80kW cells built for transportation purposes at a production rate of 500,000 units per year. Source: US DoE Technology validation project (183 FCEV); US DoE (2012a).

# The membrane electrode assembly is the main cost component of proton exchange membrane fuel cells

At the heart of the proton exchange membrane fuel cell [PEMFC] is the membrane electrode assembly [MEA], which has a thin membrane in its middle, with layers of catalysts on either side (figure 167). The MEA contributes to 30% of the total system cost (PEM stack + balance of plant). Above the catalyst there is a conductive & hydrophobic layer called the gas diffusion layer [GDL], and the MEA is sandwiched between a pair of bipolar plates.

The membrane is a non-electrically conductive solid polymer that comprises both a hydrophobic and a hydrophilic part. The hydrophilic part facilitates the transfer of protons ( $H^+$  ions) from anode to cathode, and blocks all electrons, forcing them to pass through the external circuit between the anode and cathode. The other function of the membrane is to separate reactants from the reducing environment at the cathode and the oxidative environment at the anode. DuPont's Nafion, the most common membrane, consists of a hyperfluorinated polymer that combines a hydrophobic, Teflon-like backbone with hydrophilic ionic side groups. To function, the membrane must be in a hydrated condition. Research aimed to developing cheaper membranes capable of operating under higher temperatures is under way.

The role of the catalyst (figure 168) is to break the hydrogen molecule into hydrogen ions and electrons at the anode and to split oxygen molecules at the cathode. Platinum [Pt] is the best candidate for this role, but it is very expensive and has relatively poor oxygen-reduction capabilities. Pt is also prone to rapid degradation from voltage spikes during transient fuel-cell operation (start-up/shut-down and fuel-starvation conditions). New Pt alloys are being tested to make catalysts more cost effective, durable and stable. Platinum-group metals [PGM] PtCo and PtNi have achieved mass activities of  $0.46 \text{ A/mg}_{\text{PGM}}$  and  $0.52 \text{ A/mg}_{\text{PGM}}$  respectively (surpassing the 2017 US DoE target of  $0.44 \text{ A/mg}_{\text{PGM}}$ ). Nanoparticle research aimed at replacing platinum with iron-, cobalt-, palladium- or gold-based catalysts is continuing.

Figure 167: Schematic of the PEMFC and its membrane electrode assembly

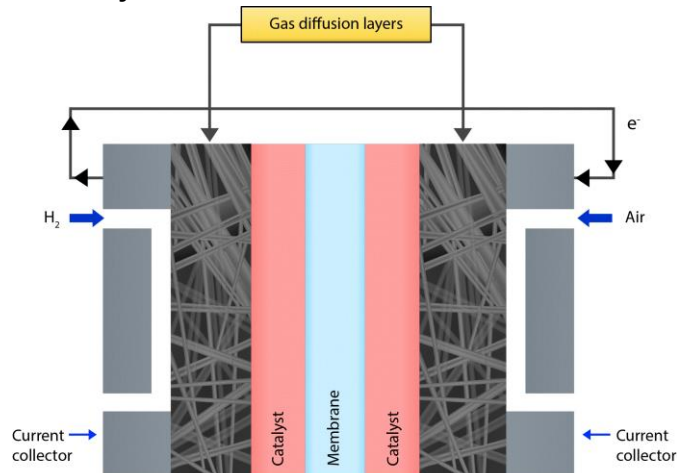
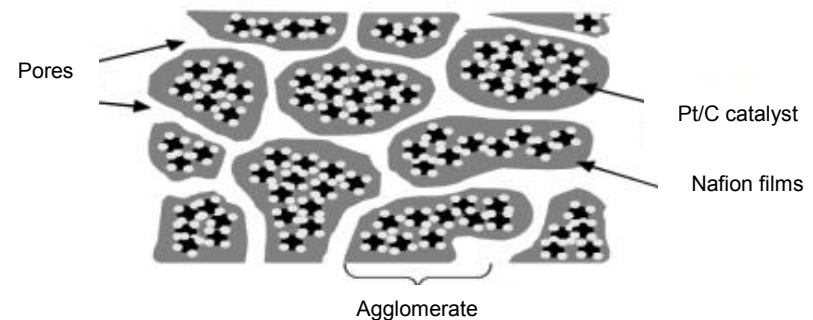

Figure 168: Proton exchange membrane platinum-based catalyst



The four layers of the catalyst are ionomer, carbon, platinum and void space or pores. At the cathode, the ionomer allows the conduction of hydrogen ions from the membrane to the reaction sites and acts as a diffusive medium for the oxygen gas. The carbon conducts electrons to the reaction site (Pt catalyst). The pores allow oxygen to flow through the layer and aid in the removal of water.

# Fuel-cell buses & forklift fleets are likely to be the first niche markets to utilize electrolytic hydrogen, and both the cost of the technology and of the hydrogen will play a role in determining market penetration

Fuel-cell personal vehicles are expensive, and fuelling infrastructure is lacking. **The first wave of commercial FCEVs would ideally have the following characteristics:** (i) **variable load** (frequent start & stops) to take advantage of the flexibility of fuel cells [FC]; (ii) **high annual mileage** to amortize capital invested; (iii) **centralized fuelling stations** for fleet FCEVs to minimize hydrogen refueling infrastructure investment; and (iv) **large vehicle sizes** to accommodate large H<sub>2</sub> tanks in addition to the FC, electric battery & motor).

**City buses (annual mileage of 60,000 km) and forklifts adapt to these parameters and could, therefore, be a niche market for FCs and reach commercialization before light duty vehicles [LDV].** Delivery vans (annual mileage of 25,000 km) and taxis are also potential candidates.

- **The forklifts** segment is already experiencing the first wave of FC application. An FC system can easily replace the battery pack in existing forklifts. The advantages are reduced refueling time (two minutes, compared with up to eight hours for charging a normal battery), steady power rating (compared with declining battery power) and a reduced inventory of batteries.
- **City buses** could be the first large-scale on-road FCEV application. The global market for buses is equivalent to 1.5 million<sup>1</sup> LDVs, providing excellent opportunities to achieve cost reductions along the learning curve (figure 169).



Fuel cell replacing batteries in forklift

**Figure 169: Summary of the performance fuel cell electric buses compared with U.S. Department of Energy & Federal Transit Administration targets**

	Units	2012 status	2016 target	Ultimate target
Bus lifetime	years/miles	5 / 100,000 <sup>4</sup>	12 / 500,000	12 / 500,00
FC & battery systems availability	hours	12,000	18,000	25,000
Bus availability	%	60	85	90
Fuel fills	per day	1	1 (< 10 min)	1 (< 10 min)
Bus cost	\$	2,000,000	1,000,000	600,000
FC & battery systems costs <sup>2</sup>	\$	700,000	450,000	200,000
H <sub>2</sub> storage costs	\$	100,000	75,000	50,000
Road call frequency	miles between road calls	2,500 / 10,000	3,500 / 15,000	4,000 / 20,00
Operation time	hours per day/days per week	19/7	20/7	20/7
Maintenance cost <sup>3</sup>	\$/mile	1.2	0.75	0.4
Range	miles	270	300	300
Fuel economy	miles per gallon diesel eq.	7	8	8

The economic viability of FC buses compared with diesel buses is determined by three main influences: 1) the cost of the hydrogen delivered at the refueling station, 2) the cost of the diesel delivered at the refueling station, and 3) the cost of the FC system (FC, H<sub>2</sub> tank, electric motor...).

The benefit of FC buses is that they are more efficient than diesel, so they use less fuel over their lifetime (fuel economy). The drawback of FCs is that the “engine” part of the bus is more costly.

While the performance of FC buses has continued to improve, there are still major challenges to overcome in meeting commercialization targets (see table).

1. Annual sales of 0.5 million buses worldwide (WBCSD, 2004), each with power requirements 2-3 times greater than LDVs; 2Cost targets projected to a production volume of 400 systems per year; 3Scheduled & non-scheduled, without mid-life overhaul of FC and battery systems; 4New buses are currently projected to have 8 year/300,000 mile lifetime.

Source: NREL (2012).

# Hydrogen internal combustion engines, which adapt familiar engine technology to reduce vehicle-manufacturing costs, have lost momentum because of the lower fuel efficiency

This type of hydrogen-fuelled vehicle uses a traditional internal combustion engine, modified to burn hydrogen instead of conventional gasoline. **The only advantages of hydrogen internal combustion engines [H2ICE] over fuel cell electric vehicles [FCEV] are that the engine design is more mature** (no limitation to lifespan), and currently cheaper. Nevertheless:

- These motors have an efficiency of 24%<sup>1</sup>, which is comparable to diesel engines and 8% more efficient than gasoline engines, but half that of FCEV motors. **Therefore, on-board H<sub>2</sub> storage tanks need to be twice as large as those in FCEV vehicles to achieve the same range<sup>2</sup>.** Besides, the vehicle's **cost of ownership is even more sensitive to hydrogen fuel costs than FCEV.**
- These motors generate significantly less power and torque than equivalent gasoline ICE engines (respectively -40% and -30% for the BMW Hydrogen 7 model<sup>4</sup>). **This calls for large engines and increases costs** compared with gasoline vehicles. New engine configurations could overcome these problems.
- Several engine modifications are required to switch from gasoline to hydrogen (figure 171).

**As a result, H2ICE has lost momentum compared with FCEV**, where there is much greater scope for reducing costs. There are currently 13 H2ICE buses running in Berlin under the HyFLEET: CUTE demonstration project, and 14 buses are being tested by US DoE. No new prototypes for H2ICE personal vehicles have been built since the BMW Hydrogen 7 in 2007 (figure 170).

**Figure 170: BMW Hydrogen 7, able to run on either liquid H<sub>2</sub> or gasoline with the same internal combustion engine<sup>2</sup>**

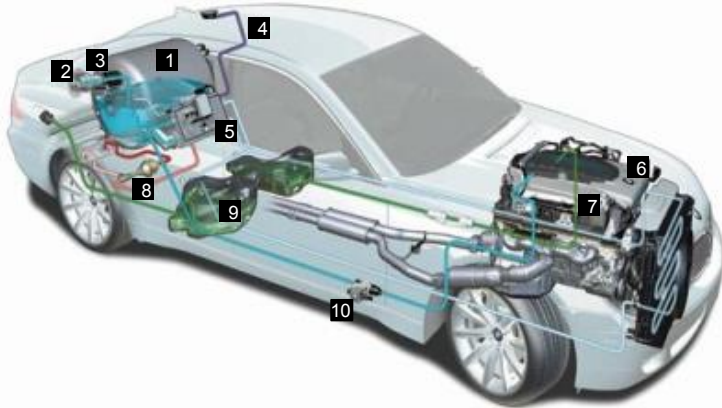

1) Liquid hydrogen tank 2) Tank insulation. 3) Hydrogen filler 4) Safety line to boil-off valve 5) Heat exchanger/control unit 6) Combustion engine 7) H<sub>2</sub> intake manifold 8) Boil-off management 9) Gasoline tank 10) Pressure control unit

**Figure 171: Main R&D axis for H2ICE<sup>3</sup>**

Even though H2ICE works on the same principles as conventional ICE, due to the properties of hydrogen, several issues must be addressed:

- Power and torque losses: new motor configurations such as direct injection or cryogenic injection are needed;
- Hot spots in the combustion chamber could cause hydrogen to pre-ignite because of its low ignition threshold;
- Embrittlement requires hardened valves and valve seats, stronger head gasket materials, piston & cylinder materials, and fuel delivery lines;
- Low density fuel requires higher voltage ignition coil/injectors;
- Gaseous fuel: fuel injectors designed for a gas instead of a liquid, modified intake manifold, positive pressure supercharger, high-temperature engine oil;
- Safety: H<sub>2</sub> sensor, storage tank ventilation, crankcase ventilation;
- NO<sub>x</sub> production: the high combustion temperature of H2ICE produces some NO<sub>x</sub> emissions, and reducing NO<sub>x</sub> pollution is costly;
- Storage tank: cryo-compressed storage tanks; and
- Other: stronger connecting rods, non-platinum tipped spark plugs, larger crankshaft damper.

1. Efficiency from Otto cycle; 2) therefore, the Hydrogen 7 prototype developed by BMW runs on liquid H<sub>2</sub> tanks instead of 700 bar compressor H<sub>2</sub> tanks to avoid (figure 169).

Source: 2. <http://simanaitissays.com/2012/10/11/hydrogen-i-c-part-3-bmw/>; 3. Florida Solar Energy Center (website).

## Hydrogen-enriched compressed natural gas vehicles may provide temporary solutions to the chicken-and-egg dilemma posed by infrastructure development, and to cleaner mobility

Hydrogen-enriched compressed natural gas [HCNG] is a third application hydrogen as a transportation fuel. There are around 14.8 million compressed natural gas [CNG] vehicles deployed worldwide, with a high proportion in Asia and South America<sup>2</sup>.

- **Blend:** typically, hydrogen can be blended at concentrations of 0-50vol.% with CNG. **The most common blend is natural gas with 20% of hydrogen by volume (also known as Hythane®).** Different blends have different effects on performance, storage and emissions. An 8% blend does not require engine re-tuning. According to research by the Automotive Research Association of India, an 18% blend provides maximum NO<sub>x</sub> reduction with the least loss of power.
- **Engine performance:** HCNG burns hydrogen faster than traditional CNG. Therefore, hydrogen can **increase engine energy efficiency**. Any energy-efficiency gain, however, does not entirely make up for **the reduction of energy storage capacity per tank** incurred by using HCNG instead of pure CNG: the fuel economy of an HCNG-powered car running on a 20vol.% blend (figure 172) would be 92% of that of a CNG vehicle (in miles per gallon, or in km per tank refueling), a decrease of 8%. The maximum engine power would also be slightly reduced.
- **Emissions:** emissions are likely to be the most important criteria for determining the best hydrogen blend. Blending in hydrogen reduces the carbon content of the fuel, **lowering tailpipe CO<sub>2</sub> emissions roughly in proportion to the hydrogen-blending ratio** (not shown in the graph). **NO<sub>x</sub> and CH<sub>4</sub> emissions would also be significantly reduced**, although not in proportion to the blending ratio (figure 172). As a result, the choice of blending ratio depends on whether greater priority is given to reducing greenhouse gases or local pollutants.

**Overall, HCNG (provided hydrogen is obtained from renewable sources) might prove a good fossil-fuel substitute where CNG infrastructure already exists.**

**Figure 172: Comparative performances of different blends when running the motor at constant full load<sup>1</sup>**

% of compressed natural gas fuel performance

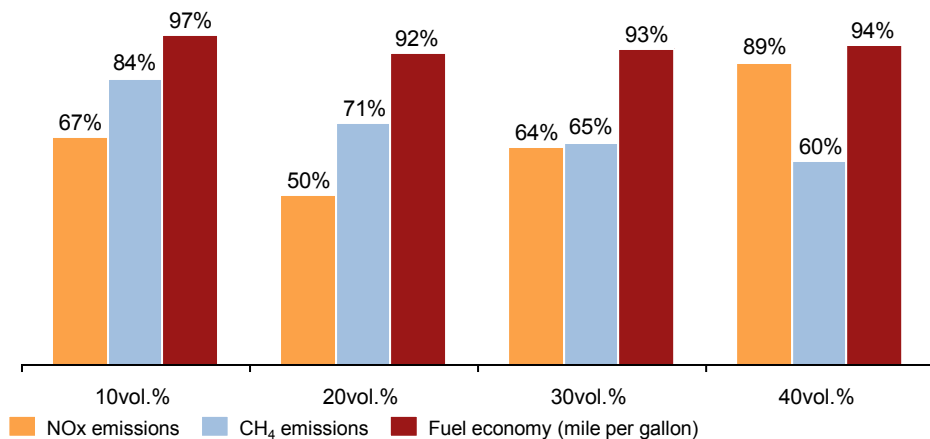

A study conducted at Tsinghua University, China, demonstrates the engine & emission performances of HCNG-fuelled engines compared with similar CNG engines running at full load of 1600 r/min.

- 20% blending results in a drop in NO<sub>x</sub> emissions of up to 50% compared with CNG. Higher concentrations of hydrogen increase the temperature of the combustion chamber and thus convert more nitrogen in the air into NO<sub>x</sub>.
- Blending hydrogen with CNG significantly reduces the emissions of unburned CH<sub>4</sub> (a greenhouse gas).
- Fuel economy (km/L) is lower than for CNG when hydrogen is blended. It decreases as the blending percentage increases because energy density is reduced and reaches a minimal blend value of 20vol.%. However, higher blends perform slightly better as they permit the engine to operate on leaner mixtures.

## Sources: section 2.6

- Aceves et al. (2013), *“Rapid High Pressure LH2 Refueling for Maximum Range and Dormancy”*, Salvador Aceves, Gene Berry, Guillaume Petitpas, Vernon Switzer, Lawrence Livermore National Laboratory
- Argonne National Laboratory – ANL (2011), *“Meeting Efficiency and Emissions Goals for Hydrogen Internal Combustion Engines”*, [http://www.transportation.anl.gov/engines/efficiency\\_goals\\_h2\\_combust\\_engine.html](http://www.transportation.anl.gov/engines/efficiency_goals_h2_combust_engine.html)
- Businesscar (2013), *“Carmakers join forces to develop fuel-cell technology”*, <http://www.businesscar.co.uk>
- College of the Desert (2001), *“Hydrogen use in the internal combustion engines”*
- Daimler AG (2013), *“Progress on FCEV development and conditions for FCEV market introduction”*, Dr. Jörg Wind, Presentation for the EC event H2 in the economy
- German Energy Agency – DENA (2012), *“Cleaner Air for All – Green Week 2013”*, Mariarosa Baroni, [http://greenweek2013.eu/sites/default/files/content/presentations/6-4\\_baroni.pdf](http://greenweek2013.eu/sites/default/files/content/presentations/6-4_baroni.pdf)
- Edwards et al. (2007), *“Hydrogen Energy”*, Peter Edwards, Vladimir L. Kuznetsov, William I. F. David, Royal Society publishing
- European Climate Foundation – ECF, *“Roadmap 2050”*, <http://www.roadmap2050.eu/project/roadmap-2050>
- Energy research Centre of the Netherlands – ECN (2009), *“PEM Fuel Cells Durability and Cost”*, Frank de Bruijn, Presentation for the Hydrogen and Fuel Cells in the Nordic Countries conference
- Florida Solar Energy Center (website), <http://www.fsec.ucf.edu/en/consumer/hydrogen/basics/utilization-ice.html>
- FuelCellToday (2012a), *“The Fuel Cell Industry Review 2012”*
- FuelCellToday (2012b), *“Fuel Cell Patent Review”*
- Greene (2013), *“Worldwide Status of Hydrogen Fuel Cell Vehicle Technology and Prospects for Commercialization”*, David Greene, Oak Ridge National Laboratory
- He et al. (2005), *“PEM Fuel Cell Catalysts: Cost, Performance, and Durability”*, Chunzhi He, Sanket Desai, Garth Brown, Srinivas Bollepalli, the Electrochemical Society Hydrogen Bus Alliance
- HyFLEET CUTE website <http://www.global-hydrogen-bus-platform.com/Home>
- International Energy Agency – IEA (2006), *“Hydrogen Production & Storage”*
- International Energy Agency – IEA (2012), *“Energy Technology Perspectives”*
- Institut Français du Pétrole et Energies Nouvelles – IFPEN (2012), *“L’hydrogène, carburant de l’après pétrole?”*
- Ma et al. (2010), *“Hydrogen-Enriched Compressed Natural Gas as a Fuel for Engines”*, Fanhua Ma, Nashay Naeve, Mingyue Wang, Long Jiang, Renzhe Chen and Shuli Zhao, Tsinghua University
- National Petroleum Council – NPC (2012), *“Hydrogen-Compressed Natural Gas (HCNG) Transport Fuel”*, [http://www.npc.org/FTF\\_Topic\\_papers/25-HCNG.pdf](http://www.npc.org/FTF_Topic_papers/25-HCNG.pdf)
- New York Energy Research & Development Authority – NYERSDA, *“Hydrogen fact sheet”*
- National Renewable Energy Laboratory – NREL (2012), *“Fuel Cell Buses in U.S. Transit Fleets: Current Status 2012”*

## Sources: section 2.6 continued

Roads2HyCom, “Case Study: Hydrogen FC Buses”, [http://www.ika.rwth-aachen.de/r2h/index.php/Case\\_Study:\\_Hydrogen\\_FC\\_Buses](http://www.ika.rwth-aachen.de/r2h/index.php/Case_Study:_Hydrogen_FC_Buses)

Russel (2013), “Investigation of the Effect of Catalyst Layer Composition on the Performance of PEM Fuel Cells”, Jason Bradley Russel

Shelby et al. (2008), “Glass microsphere for hydrogen storage”, James E. Shelby, Matthew M. Hall, National Energy Technology Laboratory

Timmons (2010), “Natural Gas fuel effects on emissions and fuel economy”, Suzanne Timmons, Southern California Gas Company

United States Department of Energy – US DoE (2012a), “Mass-Production Cost Estimation for Automotive Fuel Cell Systems”

United States Department of Energy – US DoE (2012b), “Fuel Cell Technologies Program Record”

United States Department of Energy – US DoE (2009), “Targets for Onboard Hydrogen Storage Systems for Light-Duty Vehicles”

United States Department of Energy – US DoE website, “Hydrogen Analysis Resource Center”, <http://hydrogen.pnl.gov/cocoon/morf/hydrogen>

United States Department of Energy – US DoE website, “Transportation Energy Data Book”, (<http://cta.ornl.gov/data/chapter1.shtml>)

World Business Council for Sustainable Development – WBCSD (2004), “Mobility 2030: Meeting the Challenges to Sustainability”

## 2.7 - Hydrogen-to-chemical



## Summary & key findings: section 2.7

- 1. Hydrogen is a important industrial gas**, with 87% of its consumption dedicated to the chemical and petrochemical industries. Although it is historically a captive market dominated by by-product hydrogen producers (hydrogen consumers who are also hydrogen producers) and on-purpose captive production, the merchant share is increasing and creates a significant market for electrolytic hydrogen. Industrial applications for semi-conductors, food manufacturing or hospitals, with small customers paying high prices, seems especially attractive. However, the main markets (refining and ammonia) could be more difficult to penetrate.
- 2. Refining:**
  - Refineries produce hydrogen as a by-product of catalytic reforming and consume hydrogen to reduce the sulfur content of oil fractions (hydro-treating) and to upgrade low-quality heavy oil (hydro-cracking). So, each refinery is characterized by its hydrogen balance, composed of production, consumption and losses;
  - On a macro level, the hydrogen balance of refineries has turned from positive to negative, a trend that is expected to continue due to (i) more stringent sulfur regulations, (ii) the processing of heavier crudes with a hydrogen deficit and (iii) falling demand for heavy end-products and growing demand for light products;
  - To manage this hydrogen deficit, *i.e.* to increase the hydrogen-carbon ratio of their crudes, refineries rely on conversion technologies either to extract and remove carbon (fluid catalytic cracking), giving rise to emissions, or to add hydrogen (hydro-cracking), increasing the yield. Upgrading heavy crude with electrolytic hydrogen may therefore help create cleaner transportation fuel and avoid emissions; and
  - In practice, electrolytic hydrogen is unlikely to compete in the short term with steam methane reforming due to its production costs. However, it may provide refineries at risk of a shortage of hydrogen supply with additional operational flexibility. Merchant hydrogen sourced over-the-fence tends to be more expensive than hydrogen from dedicated facilities.
- 3. Ammonia:**
  - 55% of hydrogen produced worldwide is used to produce ammonia, obtained from the catalytic reaction of nitrogen and hydrogen ( $N_2 + 3H_2 \rightarrow 2NH_3$ ). In this process, nitrogen is captured for free from the air, while the hydrogen needs to be produced. Hydrogen sourcing is, consequently, an important determinant of ammonia's production cost;
  - In practice, ammonia synthesis is usually coupled with hydrogen production from steam methane reforming, in large integrated plants. This maximizes energy efficiency (because it involves the recovery of energy excess from sub-processes, such as heat from methanation, which is then used to supply energy-deficient processes). This has resulted in a dramatic decrease in the average energy consumption of ammonia and a large reliance on natural gas, which accounts for 77% of primary feedstock; and
  - Consequently, in contrast to refineries that can adjust their hydrogen balance with external sourcing, ammonia plants are mainly a captive market. Coupling ammonia synthesis with electrolytic hydrogen production would require dedicated plants; this would reduce market opportunities in the short-to-medium term because steam methane reforming and the partial oxidation of coal are more cost-effective processes. Small-scale ammonia production for fertilizers, coupled with distributed renewable production could still make sense in remote locations. In such places, the transportation costs of ammonia could facilitate the competitiveness of electrolytic hydrogen. Several projects have been considered, but none has been completed.

## Hydrogen is an important industrial gas, with 87% of demand coming from the chemicals and petrochemicals industries

While use of hydrogen as an energy carrier is currently limited to niche applications (mainly defense, space and back-up power), hydrogen is already an important commodity in the chemicals and petrochemicals industry (figure 173), where it is used:

- To synthesize ammonia, the most common base for fertilizers (~51% of hydrogen use);
- To enhance the performance of crude oil in refineries and convert heavy/sour crude into refined transportation fuels (~38% of hydrogen use); and
- In a wide variety of other applications, such as semiconductors, food and beverages, or with metals, using its reactive and protective properties.

**Chemical hydrogen is a flourishing market and is slowly becoming less captive** (figure 174):

- Hydrogen consumption has increased steadily by 5% a year over the past decade – a growth rate that is expected to continue in the coming years;
- Hydrogen producers are also the main hydrogen consumers. This means that hydrogen is, by and large, a captive market with on-site production (accounting for 88% of hydrogen production in 2011). But the merchant share is increasing, driven by the growing needs of refineries that have turned from net producers into net consumers as a result of more stringent sulfur regulations and over-the-fence sourcing to optimize capital costs. New market forces outside the chemicals and petrochemicals industries have also shifted consumption patterns.

**Chemicals applications account for most H<sub>2</sub> consumption and so should be recognized as a major destination for excess renewable production.** Supplying clean hydrogen to refineries and ammonia plants may be a way of producing value from hydrogen and providing supplemental revenue streams.

**Figure 173: Annual worldwide hydrogen consumption 2003 – 2016, million tons**

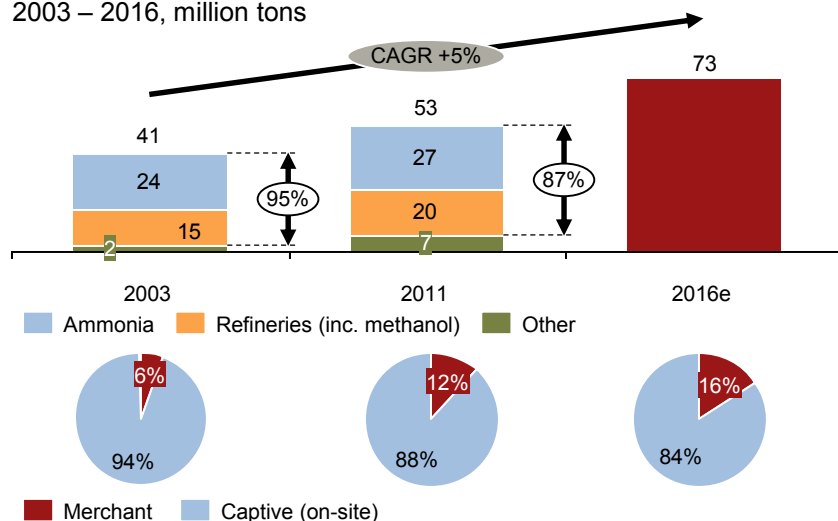

**Figure 174: Estimated US hydrogen production capacity 2003 – 2006, thousand metric tons per year**

	2003	2006	%	Δ
<b>On purpose captive</b>	<b>5,873</b>	<b>5,202</b>	<b>49%</b>	<b>-11%</b>
• Refineries	2,870	2,723	25%	-5%
• Ammonia	2,592	2,271	21%	-12%
• Other (inc. methanol)	411	208	2%	-49%
<b>On-purpose merchant</b>	<b>1,223</b>	<b>1,638</b>	<b>15%</b>	<b>34%</b>
• Off-site refineries	976	1,264	12%	30%
• Compressed gas (pipeline)	201	313	3%	56%
• Other (inc. liquid & electrolysis))	46	61	1%	33%
<b>By-product</b>	<b>3,439</b>	<b>3,844</b>	<b>36%</b>	<b>12%</b>
• Oil refineries (catalytic reforming)	2,977	2,977	28%	0%
• Other off-gas (inc. refineries)	462	478	4%	3%
• Chlor-alkali processes	N/A	389	4%	N/A
<b>TOTAL</b>	<b>10,535</b>	<b>10,684</b>		

1. Note: A 5.6% CAGR has been applied on 2011 level assuming that 35% of the growth will be derived from the merchant analysis. Source: A.T. Kearney Energy Transition Institute analysis, based on Global Industry Analysis (2012), EIA (2012a).

# Box 7: Refining operations

Crude oil is composed of chains of hydrogen and carbon molecules (hydrocarbons) of different lengths and weights; it also contains sulfur, nitrogen, oxygen and metal residues. Crude is of little value until it has been processed: it is first distilled to extract its fractions, then treated to enhance its performance and minimize its environmental impact, and, in some cases, converted to improve the yield and adjust product and demand distribution. Refinery processes vary in complexity and include hydroskimming, cracking and deep conversion.

- **Hydroskimming:** crude oil is vaporized into atmospheric distillation columns to produce different fractions: (1) light products that boil below 175°C – mainly liquefied petroleum gas and naphtha – are collected at the top of the tower; (2) heavy products with a boiling point above 370°C, known as atmospheric residues, are collected at the bottom and can be used as industrial fuel oil; and (3) various slates of distillates (e.g. heavy naphtha, kerosene, and gas oil) are extracted at intermediary levels of distillation. Further processes are then needed, mainly catalytic reforming to convert naphtha into higher-octane range products, and hydrodesulfurization [HDS] to reduce the sulfur content of the end products;
- **Cracking:** this is the simplest way of processing atmospheric residues into lighter and higher-value end products (cracking long-chain hydrocarbons into shorter ones). Residues are first distilled at low pressure in vacuum distillation units. Gas oil and distillate slates extracted from the column are then cracked in fluid catalytic cracking or hydrocracking units to obtain better-quality gas oil, before being treated to reduce their sulfur content in a hydrodesulfurization unit;
- **Deep conversion:** this is similar to the cracking process but converts residues from the vacuum distillation column into useful products, using technologies such as coking and hydrocracking.

Figure 175: Schematic of refining operations

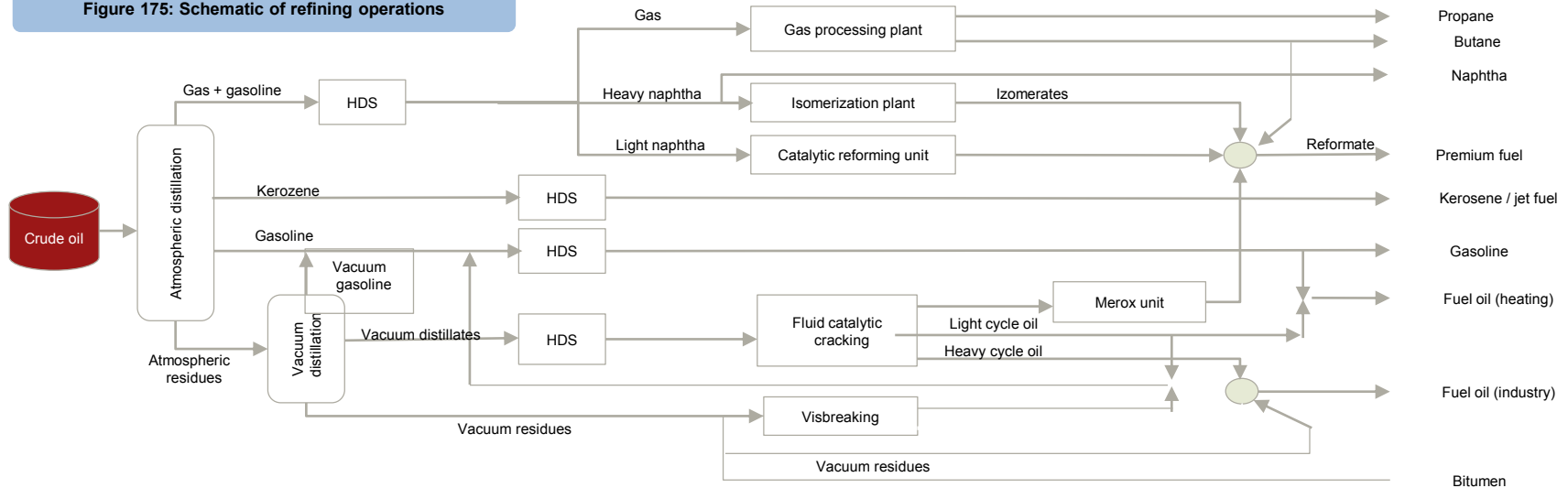

Note: HDS: hydro-desulfurization.  
Source: IFPEN – CEA (2012a).

## Refineries are characterized by the hydrogen consumption, production and losses that make up their hydrogen balance.

Refineries both produce and consume hydrogen in the course of their operations. Hydrogen is consumed in the hydrogenation processes used to reduce the sulfur content of oil fractions and to upgrade low-quality fractions – from atmospheric and vacuum distillation towers, and fluid catalytic and coking units – into light fractions, e.g. jet fuel, diesel and gasoline (figure 176).

- *Hydro-treating*: reduces sulfur content in oil products. Hydrogen is injected at high temperature and pressure to react with hydrocarbon molecules in the presence of a catalyst to form hydrogen sulfide [H<sub>2</sub>S]. This is then removed and converted to sulfur or sulfuric acid for use in the chemicals industry;
- *Hydrocracking*: heavy oil is mixed with hydrogen gas and subjected to high temperatures in reactors filled with catalysts. These catalysts break down long hydrocarbon chains into shorter, unsaturated molecules that can absorb more hydrogen atoms, thereby increasing their hydrogen-to-carbon ratio.

Hydrogen is also an important by-product of catalytic reforming, which is part of a dehydrogenation process in which naphtha molecules, under high pressure and temperature and in the presence of a catalyst, are restructured into smaller, higher-octane and more volatile molecules. This process generates large volumes of hydrogen gas, which is usually recovered (figure 177).

Hydrogen is partially lost in these processes and in the network linking production and consumption centers. Losses can occur in the separator, but also in the hydrogen network to maintain pressure. These losses can be minimized or partly recovered by, for instance, pressure-swing absorption units.

Each refinery is therefore characterized by a hydrogen balance calculated by: **consumption – production + losses**. This balance depends on the quality of the crude oil and the processes to which it is subjected. Figure 176 gives examples of hydrogen balances.

Figure 176: Typical hydrogen net consumption by refining process

	Process	Hydrogen consumption (% weight of feed)
Hydro-desulfurization	Naphta before reforming	0.05 – 0.2%
	Naphtha from conversion	0.5 – 1%
	Kerosene	0.1 – 0.3%
	Diesel	0.1 – 0.5%
Hydro-cracking	Low pressure (<50% conversion)	0.5 – 1%
	High pressure (80-100% conversion)	1.0 – 2.5%
	Residues	0.5 – 1.5%

Figure 177: Catalytic reforming illustration

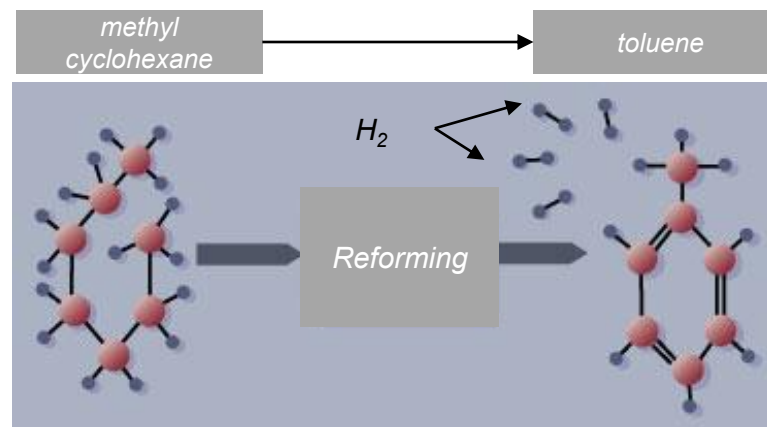

## The quality of crude oil has a significant effect on demand for hydrogen. The sourer and heavier the crude, the greater the amount of hydrogen needed

**The sourer a crude oil, the greater the amount of hydrogen needed for sulfur removal.** The sulfur content of crude oil and environmental regulations governing sulfur limits in fuels are, consequently, the principal determinants of hydrogen consumption for hydro-desulfurization.

**Stringent vehicle and power-plant regulations have been implemented** in recent decades in North America, Europe and Asia to prevent sulfur dioxide emissions [SO<sub>2</sub>], due to their negative health effects and role in creating acid rain. The stricter rules have transformed the hydrogen balance of refineries, especially because the amount of hydrogen needed for desulfurization increases at a disproportionately higher rate than increases in the degree of desulfurization (figure 178).

**Heavy crudes contain a relatively low share of light fractions that can directly be processed into high-value products** (gasoline, liquid petroleum gas, diesel and naphtha). **In chemical terms, this can be explained by their insufficient hydrogen-to-carbon (H/C) ratio** (figure 179). Light fractions<sup>1</sup> have an excess of hydrogen that can be recovered during catalytic reforming; but distillates and heavy fractions tend to be deficient in hydrogen. As a result, refineries have developed conversion technologies that strive to increase the H/C ratio of heavy fuels. Originally, this was done by extracting carbon from the fuel (fluid catalytic cracking); this reduced carbon in the ratio, but gave rise to emissions. **More recent technologies have favored hydrocracking, which adds hydrogen to cracked molecules**, improving the quality of end products and plant yield, as well as limiting carbon emissions.

**With the notable exception of light sweet oils from the Bakken and Eagle Ford shale formations in the US, crude oils are, in general, becoming heavier** (e.g. Canadian Alberta and Venezuelan Maracaibo Boscan oil). As heavy fuels tend also to be sour, this trend will simultaneously result in higher hydrogen consumption for desulfurization and lower hydrogen production from catalytic reforming.

**Figure 178: Global sulfur limits & hydrogen need for differing levels of removal**

Parts per million (ppm), as of April 2012

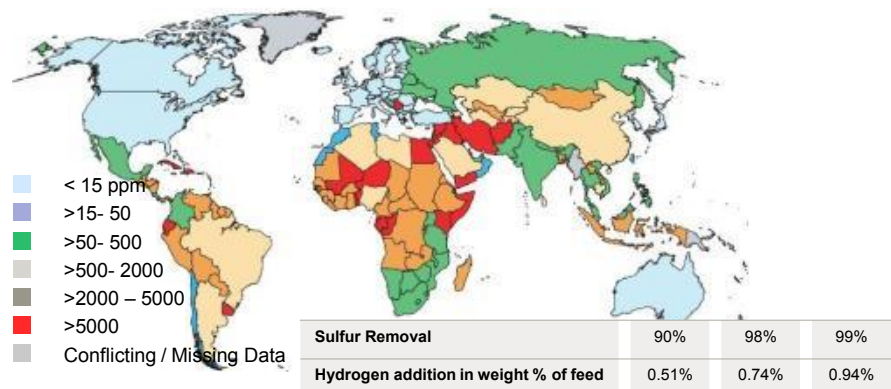

Note: Emissions limits may be higher in specific cities (e.g. Beijing in China). China is likely to make its regulation much more stringent according to some sources (down to 50 or 15 ppm by 2017). API for American Petroleum Institute gravity, is a measure of how heavy or light a petroleum liquid is compared to water.

Source: UNEP (2010); IFPEN (2012); OGI (2009).

**Figure 179: Average hydrogen-to-carbon ratio (H/C) of crudes**

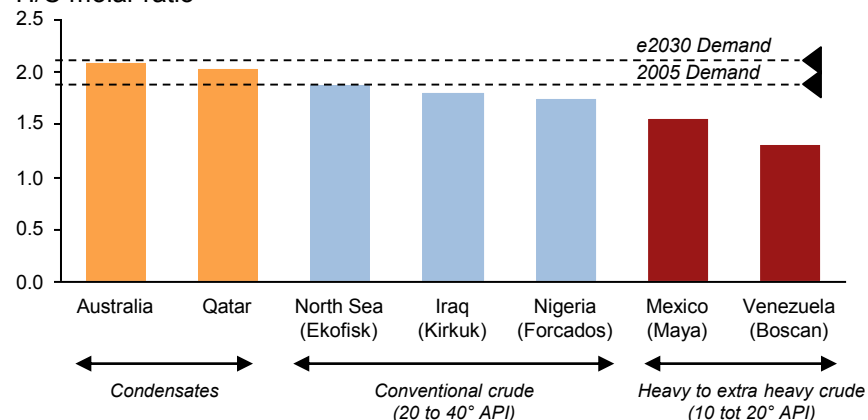

## Greater use of heavier crude oils and falling demand for heavy fuel oil are expected to increase hydrogen demand from refineries

**Refineries have two primary objectives:** (1) to extract petroleum products from crude oil and treat them so that they meet the required standards; and (2) to ensure that the distribution of products matches demand in a given market.

**The demand structure for oil products has been changing** since the oil crisis of the 1970s. Low-value heavy products such as fuel oil for heating and industry have become less competitive than alternatives, such as gas or coal. As a result, demand for them is decreasing. At the same time, demand has been increasing for light products. The chemicals industry has increased its consumption of naphtha; diesel has become a popular alternative to gasoline in road transport; and demand for jet fuel has risen as the aviation sector has expanded.

**The increasing use of heavy crudes, with fewer light fractions, combined with structural changes on the demand side, has created a mismatch between crude oil supply and demand.** This mismatch, which is expected to increase (figure 180), reinforces the need for conversion technologies to maximize the light product yield from crude oil.

**As crudes are, overall, deficient in hydrogen, and as carbon-emissions regulations and energy efficiency favor hydrogen enrichment (hydrocracking) over carbon rejection (from fluid catalytic cracking), the hydrogen balance in refineries is expected to grow negatively.** Hydrogen demand models, which take into account growing use of heavy crude oil with deep conversion, forecast that this negative balance could reach 2% in weight for heavy sour Maya crude, and up to 3.5% for Boscan Oil with 80% conversion (figure 181). While this may seem limited at first sight, it represents up to 10% of the energy value of H<sub>2</sub> per barrel of crude. Hydrogen procurement will thus be increasingly desirable for refineries and could help reduce the carbon intensity of fossil fuels, if it is sourced in a clean way.+

**Figure 180: Distribution of oil fractions and average H/C ratio**  
% of weight of crude feed ranked by API index from extra heavy to condensate

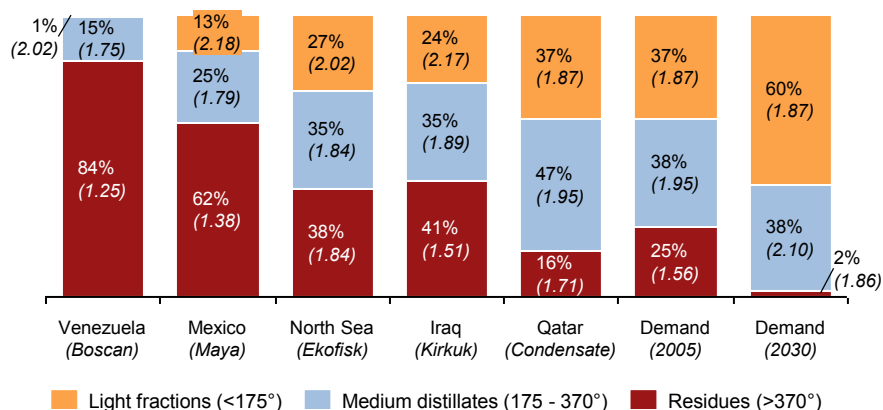

**Figure 181: Net hydrogen balance by typical refining schemes**  
AL = Arabian Light, Maya = Heavy Mexican oil

Scheme	Crude Oil	H <sub>2</sub> / Crude Oil (% Weight)	Gasoline & Diesel Yield (% weight / Crude Oil)
Hydroskimming	AL	0%	54.2%
	Maya	0%	29.5%
Cracking – maximized for gasoline	AL	0.2%	75.9%
	Maya	0.1%	38.7%
Cracking – maximized for distillates	AL	0.7%	76%
	Maya	0.5%	38.1%
Deep conversion – maximized for distillates	AL	1.29%	88.7%
	Maya	1.5%	57.2%
Ultra deep conversion – maximized for distillates	AL	1.33%	91.3%
	Maya	2%	79.1%

## Sourcing hydrogen by electrolysis from temporary excesses of electricity from renewable energy could provide flexibility for refineries, which are sometimes constrained by their hydrogen balance

The hydrogen balance of refineries can be classified in three ways: (1) **Refineries with excess hydrogen**. No constraints; hydrogen can even be rerouted to the fuel-gas system and valorized at the fuel-gas price; (2) **Refineries close to equilibrium**; sometimes short of hydrogen. Output from catalytic reformers is not always sufficient to cover the refinery's needs; hydrogen supply is a constraint on operations and profitability; and (3) **Refineries short of hydrogen**, but with built-in production units or connection to a hydrogen network.

**Electrolytic hydrogen may be valuable to refineries close to equilibrium.** If the hydrogen network has already been optimized, these refineries are facing arbitrage between their operations (e.g. curtail the volume of crude oil treated to preserve the quality and volume of light products; keep the volume of crude oil unchanged while reducing conversion; or switch to carbon rejection). When arbitrage is possible, hydrogen is priced at the opportunity cost (up to \$10 /kg, or ~ \$254 /MWh according to some reports), i.e. one of the highest market prices.

If the hydrogen shortage is recurrent, refineries will consider investing in a dedicated hydrogen generator or agree on merchant procurements over-the-fence to avoid capital costs. Electrolysis cannot compete with steam methane reforming for continuous, dedicated hydrogen generation. However, as merchant hydrogen is expensive (\$6-10 /kg, or \$152-254 /MWh) and as hydrogen demand varies, according to the quality of crudes being processed, refineries **may prefer flexibility – avoiding dependence on expensive merchant hydrogen. In this situation, small-scale electrolytic hydrogen may be worth considering.**

The introduction of carbon-emissions regulations or carbon pricing mechanisms, such as the European Union's Emissions Trading Scheme – in markets where such systems are absent – would encourage the production of clean hydrogen.

**Figure 182: Using wind energy to upgrade bitumen from Alberta's oil sands** (model from B. Olateju and A. Kumar)

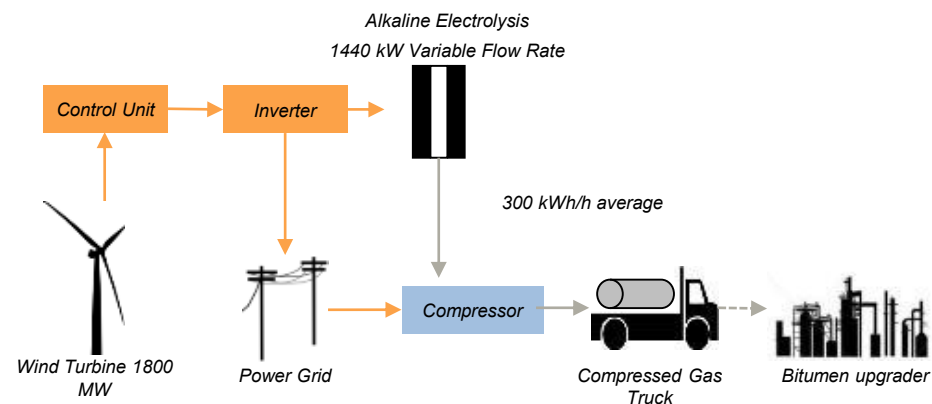

### MODEL DESCRIPTION & RESULTS<sup>1</sup>

- Model assumptions: Power produced from the wind turbine can go to the grid or to the electrolyzer. An optimal variable flow rate of 27 kWh<sub>ch</sub>/h has been determined. Results include all costs, from investment in wind through to delivery.
- Hydrogen production costs: \$183 /MWh<sub>ch</sub> H<sub>2</sub> for the production compared to ~\$23 /MWh<sub>ch</sub> H<sub>2</sub> for steam methane reforming. Around \$145 /MWh<sub>ch</sub> H<sub>2</sub> should be added for the full delivery cost of 27kWh<sub>ch</sub>/h whatever the production technology. Note that an electricity feed-in-tariff of \$0.12 /kWh for renewable electricity would lower production cost to ~\$122 /MWh<sub>ch</sub> H<sub>2</sub> and favor a higher production mode (up to 90kWh<sub>ch</sub>/h) reducing delivery costs to \$121 /MWh<sub>ch</sub> H<sub>2</sub>
- Life-cycle CO<sub>2</sub> emissions: 26.7 kgCO<sub>2</sub>/MWh<sub>ch</sub> H<sub>2</sub> mainly during wind construction & operations vs. ~305 kg CO<sub>2</sub>/MWh<sub>ch</sub> H<sub>2</sub> for steam methane reforming. For both, 135 kg CO<sub>2</sub>/MWh<sub>ch</sub> H<sub>2</sub> should be added due to compression and transportation. With a production cost difference of \$160 /MWh<sub>ch</sub>, this translates into a carbon mitigation cost of \$576 /tCO<sub>2</sub> avoided.

1. It should be noted that this model is adapted for Canada. An exchange rate of US\$= C\$044 has been applied. It is based on a study of a greenfield investment (new wind turbine) rather than using surplus from existing farms.

Source: Olateju et al. (2011).

# Box 8: Ammonia basics

## ID Card

- **Properties:** ammonia is a compound of nitrogen and hydrogen with the formula NH<sub>3</sub>. It is a colorless gas, easily liquefied, with a boiling point of -33.3°C at standard atmospheric conditions. Anhydrous ammonia refers to pure ammonia (*i.e.* without water), while household ammonia refers to an ammonia solution.
- **Applications:**
  - **Fertilizer:** ammonia is primarily valued for its nitrogen content, which makes it a key intermediate step in the production of fertilizers such as urea, ammonium nitrates or ammonium phosphates, but also useful for other direct applications. Nitrogen is vital for plant photosynthesis;
  - **Neutralizing flue gas:** used to react with NO<sub>x</sub> emissions from diesel engines to form nitrogen and water vapor and to scrub SO<sub>2</sub> in power plants;
  - **Refrigerant:** used as a working fluid in industrial refrigeration because of its high latent heat of vaporization; and
  - **Other:** cleaning agent, synthetic fiber production (*e.g.* acrylics, nylon), explosives *etc.*
- **Production:**
  - **Technology:** until World War I, ammonia was mostly obtained by dry distillation of nitrogenous vegetal and animal wastes, as well as from mineral sodium nitrate (NaNO<sub>3</sub>), found almost exclusively in the north of Chile. In the early 20<sup>th</sup> Century, Fritz Haber discovered a process to produce ammonia from nitrogen synthesized from air. Since then, virtually all ammonia has been synthesized using his process. Having relied on a variety of feedstocks for hydrogen production as an intermediate step in ammonia production (coal, light hydrocarbons, electrolysis, naphtha), the process is now largely dependent on natural gas, which provides 77% of the hydrogen needed for ammonia production.
  - **Producers:** 137 Mt of ammonia was produced in 2012<sup>1</sup>, compared with 102 Mt in 2002, a 25% increase. As ammonia is costly and difficult to transport, most consumption occurs near the point of production. China is by far the largest producer and also the largest consumer. Gas-producing countries that can rely on a cheap feedstock have developed export facilities, notably Trinidad, which provides 60% of US ammonia imports, the former Soviet Union countries, the Middle East (*e.g.* new plants commissioned by QAFCO in Qatar) and Canada. Leading companies producing ammonia include Norway's Yara, CF Industries and Koch from the US, Potash Corp and Agrium from Canada, TogliattiAzot and Eurochem from Russia, Sinopec from China and IFFCO from India<sup>2</sup>.

## Figure 183: Consumption by end use in 2010<sup>3</sup>

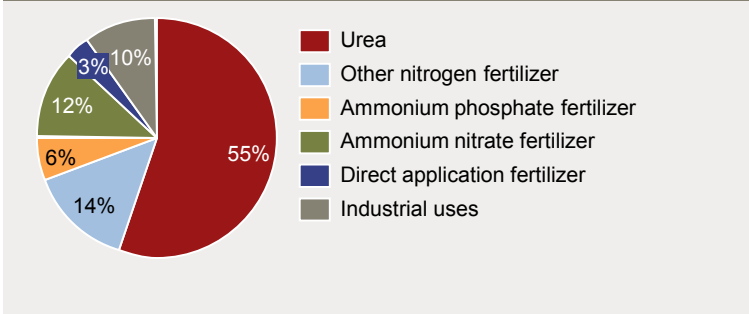

## Figure 184: Top 10 producing countries in 2012 (thousand tons)<sup>1</sup>

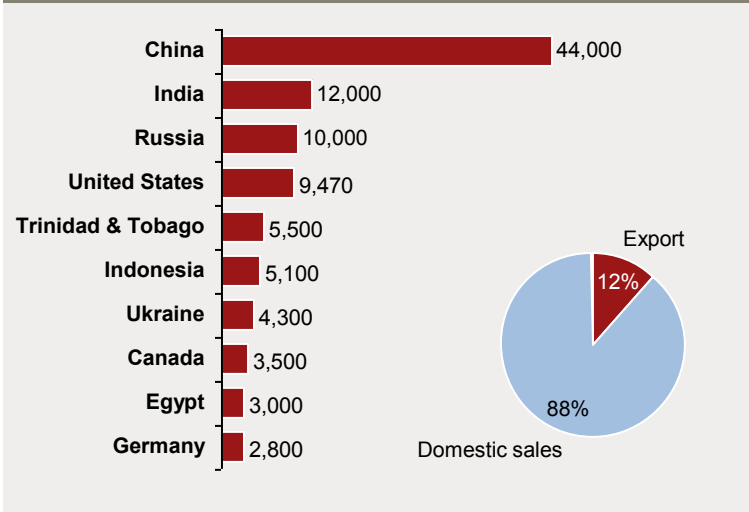

# More than half of the hydrogen produced worldwide is used to manufacture ammonia using a catalytic reaction of nitrogen and hydrogen

**Ammonia [NH<sub>3</sub>] is one of the most extensively produced chemicals in the world**, helping create over 500 million tons of nitrogen fertilizer per year (see Box 8: ammonia basics). Virtually all production uses the Haber-Bosch process, which fixes nitrogen from the air [N<sub>2</sub>] to hydrogen [H<sub>2</sub>]. Discovered by Fritz Haber and perfected by Carl Bosch in the early 20<sup>th</sup> century, **its basic chemistry (N<sub>2</sub> + 3H<sub>2</sub> -> 2NH<sub>3</sub>)** occurs in the presence of a catalyst (typically iron) at temperatures of 350-500°C and pressures of 80-300 bar.

Ammonia is valued for its nitrogen content (~82% of its weight). Nitrogen is a rare molecule in the Earth but is freely available in the atmosphere. However, hydrogen, which is essential to the production of ammonia, must also be **produced. It is the main input for ammonia production, along with water and the necessary energy.** According to the Haber-Bosch equation, 162 kg of hydrogen are needed to produce one ton of ammonia, excluding hydrogen losses and consumption for energy purposes. In 2012, 26.5 million tons of hydrogen were used to produce 137 million tons of ammonia, *i.e.* 55% of total hydrogen consumption.

**Unlike refineries, ammonia plants do not produce hydrogen as a by-product; they depend entirely on dedicated hydrogen production**, mainly from steam reforming of natural gas (77%) and coal gasification (14%). A smaller contribution is made by partial oxidation of heavy (2%) and light (7%) hydrocarbons (figure 185). Electrolysis coupled with hydropower used to be a popular choice for producing ammonia but has become much less common and is on the verge of disappearing entirely, as the last large-scale ammonia-producing facility using this approach – in KweKwe, Zimbabwe – switches to coal.

**Figure 185: Feedstock distribution for ammonia production**

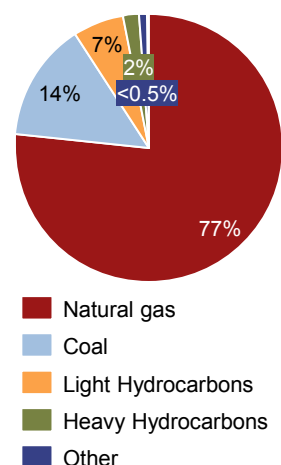

- Natural gas is by far the largest feedstock. Low US gas prices have boosted domestic production, encouraging construction of new plants, such as that built by Orascom to produce 2 million tons a year of ammonia and 2 million tons a year of urea.
- Coal is mainly used as a feedstock in China, especially for small and medium-sized facilities. China is virtually the only user of coal as feedstock apart from a few plants elsewhere (e.g. in Vietnam), although Indonesia and Australia have plans to use coal in the future.
- Light hydrocarbons used for ammonia production include liquid petroleum gas, refinery off-gases and naphtha. The latter is relatively widely used in India, where several plants accept both natural gas and naphtha as feedstocks. This may mean the amount of naphtha used is being underestimated.
- Heavy hydrocarbons, including fuel oil and vacuum residues, are used less and less often, due to the deeper conversion processes of refineries and poorer quality (hydrogen content) of the products (see Box 7: refining).

**Figure 186: Greenfield fertilizer plant of Sorfert Algeria built by Orascom Construction Group<sup>1</sup>**



Note: N<sub>2</sub> + 3H<sub>2</sub> -> 2 NH<sub>3</sub> is equal in mass to 28g + 3 x 2.02 g -> 2 x 17g so you need 162 kg of hydrogen to produce one ton of ammonia.

Source: A.T. Kearney Energy Transition Institute analysis, based on International Fertilizer Association (1997); IEA (2012a); Image courtesy of: 1Orascom Construction Group. Sorfert is a greenfield fertilizer plant commissioned by Orascom in 2013 in Algeria. It is supplied in natural gas by Sonatrach and has a capacity of 2.200 t/d of ammonia and 3.400 t/d of urea. energy 161

## In practice, ammonia synthesis is coupled with hydrogen production from steam methane reforming in large integrated plants to maximize energy efficiency

The cost of ammonia production is mainly linked to the cost of the hydrogen and energy needed. When hydrogen is sourced from steam methane reforming, an average of 70-85% of the production cost comes from natural gas.

The first ammonia plant designs consisted of several parallel units carrying out separate processes. In the late 1960s, there was a general shift towards integration. Rising feedstock prices and engineering advances in the refining industry led to the design of integrated steam reforming ammonia plants: large-scale, single-train units integrating steam reforming of natural gas to produce hydrogen and ammonia synthesis (figure 187). Integration, upscaling and gas use – all designed to improve energy efficiency – helped recover excess energy (e.g. heat from methanation) to supply other processes (e.g. reforming or CO<sub>2</sub> removal).

This has led to a dramatic fall in average energy consumption, from 88 GJ per ton of ammonia consumed in early coke multi-line plants to 25 GJ in modern steam plants (around 35 GJ and 45 GJ respectively for partial oxidation of vacuum residues and coal). Ammonia plants could even be integrated into other production processes (e.g. urea production) to optimize the whole value chain.

In most cases, the combination of the low energy intensity of steam methane-based ammonia plants, and low up-front capital costs (the process is 1.5-2.5 times less capital-intensive than partial oxidation) offset high feedstock prices (gas price vs. coal price). This has made gas the dominant feedstock for new ammonia plants.

Figure 187: Simplified integrated steam methane reforming flow diagram

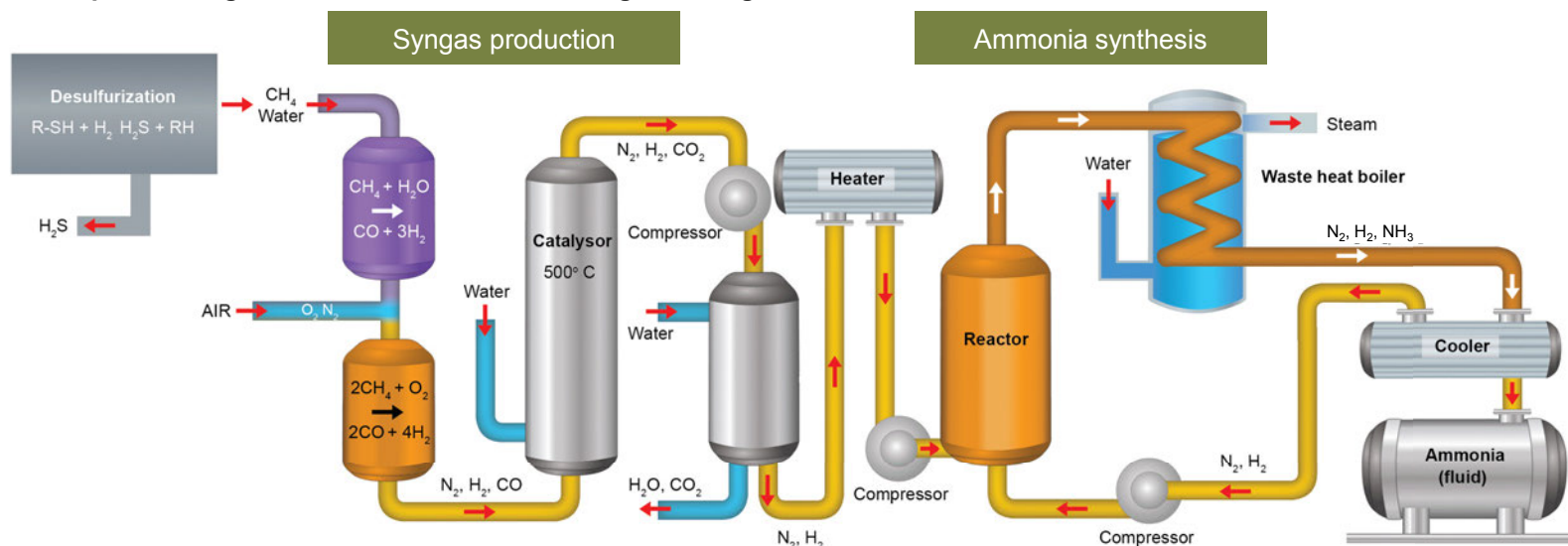

Note: This can be explained by the need for stand-by units to avoid production interruption during periodic burner changes and cleaning operations in partial oxidation plants.

Source: A.T. Kearney Energy Transition Institute analysis, based on EFMA (2000) and International Fertilizer Association (1997).

## Using surplus energy from intermittent power sources to produce hydrogen feedstock for ammonia plants is likely to be limited to the production of fertilizers in remote locations

The use of surplus energy from intermittent energy sources to produce hydrogen feedstock for ammonia plants is very unlikely in the medium term, because ammonia synthesis uses hydrogen produced from integrated steam reforming and partial oxidation. These processes do not allow external feeds of hydrogen. Unlike refining where hydrogen needs may be met by merchant procurement, ammonia production is generally a fully captive market.

In the short-to-medium term, small-scale ammonia production for fertilizers, coupled with distributed electrolytic hydrogen production, could make economic sense in some remote locations. Transporting ammonia incurs significant additional costs: considered a hazardous substance, it must be transported in refrigerated vessels or pressurized containers. In the late 2000s, the transportation cost represented around 20% of the price of ammonia if shipped from Trinidad to the US Gulf Coast, and up to 50% when shipped from Russia. Farmers in the north-west US paid 25-75% more for ammonia transportation than southern and central regions, even though the US has highly developed ammonia infrastructure (import terminals, trains with pressurized tanks, pipelines). It would seem that remote communities in need of ammonia might be better off producing it themselves from small-scale plants using renewables.

Local sourcing of ammonia could be promoted if governments were willing to protect farmers from the volatility of fertilizer prices and by the seasonal use of fertilizers used in a very short timeframe before planting and after harvest. Consequently, producing fertilizer using electrolytic hydrogen produced from renewables would mainly be valuable in remote locations with no gas resources and a poorly developed power grid.

Several projects were planned but were not completed. The US planned projects in the late 2000s when gas prices were at their highest<sup>1</sup> (such as the Freedom Fertilizer project in figure 188), but these initiatives stalled because of the discovery of shale gas. However, projects may still be relevant on islands or for remote communities with poor or no access to the fertilizer market. For example, Dutch firm Proton Ventures is commercializing 'mini-ammonia' plants, which use alkaline electrolysis (figure 189).

Figure 188: Freedom Fertilizer wind-to-ammonia process

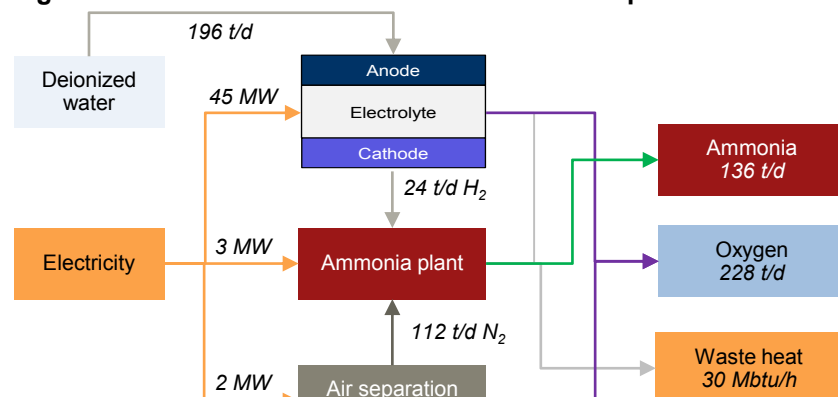

Note: Nitrogen fertilizer may account for 10% of the cost of production of wheat. With rising gas prices in the 2000s and concerns for security of supply, the US corn belt, with its high wind speeds, poor power network, and long distance from ammonia terminals, was seen as a favorable place to develop innovative projects, such as the Minnesota Wind to Ammonia Pilot System.

Source: Images courtesy of: Proton Ventures (2012); University of Minnesota (2007); Freedom Fertilizer (2012); USDA (2007a).

Figure 189: Proton Venture mini wind-to-hydrogen plant design

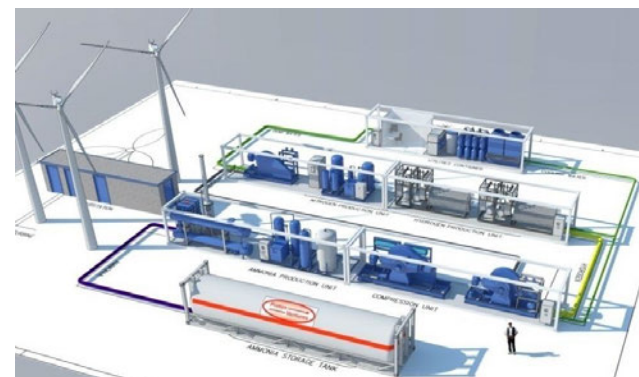

## Sources: section 2.7

- ChemSystems– (2012), *“Ammonia and Urea Strategic Business Analysis”*, [http://www.chemsystems.com/reports/search/docs/toc/SBA09\\_Ammonia\\_Urea\\_TOC.pdf](http://www.chemsystems.com/reports/search/docs/toc/SBA09_Ammonia_Urea_TOC.pdf)
- EMPA– (2012), *“Chemical energy Storage Synthetic fuels: Catalysis and Synthetic Fuels”*
- European Fertilizer Manufacturing Association – EFMA (2000) a, *“Best Available Techniques. for Pollution Prevention and Control – Production of Ammonia”*
- Global Industry Analysis – GIA (2012), *“Hydrogen Production and Storage Technologies – a global strategic business report”*
- Institut Français du Pétrole Energies Nouvelles – IFP EN (2012), *“L’hydrogène, carburant de l’après-pétrole?”*
- International Energy Agency – IEA (2012a), *“World Energy Outlook 2012”*
- International Energy Agency – IEA (2009b), *“Chemical and Petrochemical Sector: Potential of best practice technology and other measures for improving energy efficiency”*
- International Fertilizer Association – IFA (1997), *“The Haber-Bosh Heritage: The Ammonia Production Technology”*
- Oil & Gas Journal – OGJ (2009), *“Refinery Gases: Hydrogen, nitrogen assist compliance with new, tougher environmental regs”*
- Oklahoma State University – (2010), *“Causes of Fertilizer Price Volatility”*
- Potashcorp – (2012), *“2011 online review”*, [http://www.potashcorp.com/industry\\_overview/2011/nutrients/40/](http://www.potashcorp.com/industry_overview/2011/nutrients/40/)
- Proton Ventures BV – (2012), *“NFuel: Mini Ammonia Units”*
- Olateju et al. (2011), *“Hydrogen production from wind energy in Western Canada for upgrading bitumen from oil sands”*, Babatunde Olateju, Amit Kumar, Energy 36, pp. 6326-6339
- Stanford Linear Accelerator National Laboratory – SLAC National Laboratory (2011), *“Phrase of the Week - Haber-Bosch Process”*
- United Nations Environmental Program – UNEP (2012), *“Diesel Fuel Sulfur Levels: Global Status April 2012”*
- United States Department of Agriculture – USDA (2007a), *“Impact of Rising Natural Gas Prices on U.S. Ammonia Supply”*
- United States Department of Agriculture – USDA (2012b), Download from Economic Research, <http://www.ers.usda.gov/data-products/fertilizer-use-and-price.aspx>
- United States Department of Energy – US DoE (2006), *“Potential Roles of Ammonia in a Hydrogen Economy”*
- United States Energy Information Administration – EIA (2008a), *“The Impact of Increased Use of Hydrogen on Petroleum Consumption and Carbon Dioxide Emissions”*
- United States Energy Information Administration – EIA (2012b), *“Crude oils have different quality characteristics”*
- United States Geological Survey – USGS (2004a), *“Mineral Commodity Profiles: Nitrogen”*
- United States Geological Survey – USGS (2012b), Download from Mineral Commodities Summaries, <http://minerals.usgs.gov/minerals/pubs/commodity/nitrogen/>
- University of Minnesota – (2007), *“Wind to Hydrogen to Ammonia”* - Advanced Wind Workshop II

## 2.8 - Integrated hydrogen projects



## Summary & key findings: section 2.8

1. **This section focuses on integrated projects converting electricity into hydrogen for direct energy use** (electricity, H<sub>2</sub> or syngas). Non-energy uses of electrolytic hydrogen, such as ammonia, cooling fluid, space or military applications (which represent around 100 MW of installed capacity) are excluded.
2. **Integrated projects are at the early demonstration phase**, with 15.9 MW<sub>e</sub> of capacity installed and 10.8 MW<sub>e</sub> under construction. There seems to be a growing enthusiasm for P2G projects, and a slowdown in development of electrolytic-H<sub>2</sub> refueling stations. Meanwhile, re-electrification projects remain at the kW-scale at present. Developments comprise:
  - 5.7 MW<sub>e</sub> of H<sub>2</sub> refueling stations, with on-site electrolytic H<sub>2</sub> production;
  - 11.5 MW<sub>e</sub> of P2G, with only 2.4 MW in operation;
  - 5 MW<sub>e</sub> of electrolytic methanol production, at a single plant; and
  - 2.5 MW<sub>e</sub> of re-electrification plants (operating, or under construction).
3. **This section provides framework analysis of the techno-economic trade-offs** faced by any developers of integrated projects:
  - Firstly, project layouts (type of power source, location of the electrolyzer and transport distance) differ according to whether the plant is centralized or decentralized (at the energy-consumption site); and grid-connected or using off-grid electrolyzers;
  - For each project layout, the optimal utilization profile and plant configuration (component sizing, technology of choice) will be influenced by the cost profile of electricity supply and the potential market value of plant output. Plant economics could be improved by reducing the annual load factor or from volatility in electricity prices, even if it means building some oversized components into the value chain to maintain the same annual output. Noticeably, the efficiency of components downstream in the value chain is more important than those upstream (such as the electrolyzer), because it avoids costly oversizing of the whole chain;
  - For now, price variations on most electricity spot markets are too small to enable significant hydrogen production-cost reductions resulting from discontinuous operation of grid-connected electrolyzers;
  - Because of energy losses and capital costs, the price of chemical energy produced will be more than three times higher than the cost of electrical energy input. This ratio can reach seven for re-electrification projects with very low round-trip efficiency. More detailed results are given in [Section 3](#);
  - Large price spreads between the electrical-energy input and chemical- or electrical-energy output are fundamental to a project's profitability. Such price spreads appear when the power market expresses a need for energy time-shifting, location-shifting or application-shifting (see [Section 1.4](#));
  - In practice, revenue streams from integrated projects can be classified as: energy feedstock end-product sales – methane in \$/kWh<sub>ch</sub>, for example; by-product feedstock sales – such as oxygen in \$ per ton; and power-grid services – for example, fast-control reserve paid in \$/kW<sub>e</sub> per hour of availability.

# Integrated projects utilizing H<sub>2</sub> from electrolyzers are in the early demonstration phase – non-refueling stations

This section analyses integrated projects using electrolytic H<sub>2</sub> for energy purposes – commercial electrolysis applications<sup>1</sup>, representing 100 MW of capacity addition or replacement, are excluded. Such projects are in the early demonstration phase. In May 2013, their combined power usage was between 13 and 19 MW<sub>e</sub>, plus 13 MW<sub>e</sub> at the planning stage. The largest operating project is a 5 MW<sub>e</sub> power-to-methanol pilot plant in Iceland; also, a 5 MW<sub>e</sub> P2G pilot is under construction in Germany. Integrated projects serve one of two markets: **H<sub>2</sub> fueling stations** (see next slide); and **non-refueling stations**<sup>2</sup>, utilizing H<sub>2</sub> to produce electricity, heat, synthetic fuels (such as methane, methanol and gasoline):

- **Projects:** 43 completed (including 13 mothballed; eight in Germany; six in the US; and four in the UK); and 11 planned (six in Germany);
- **Capacity (figure 190):** installed operating capacity is 10.2 MW<sub>e</sub>, with 10.3 MW<sub>e</sub> planned. Seven projects have a capacity greater than 1 MW<sub>e</sub><sup>3</sup>;
- **Electricity source:** around 70% of electricity for completed projects is supplied by a dedicated, renewable plant. Most of the planned capacity, however, will rely on a national grid; and
- **Electrolysis technology:** proton exchange membranes (PEM) have been used only for projects smaller than 50 kW<sub>e</sub>, totaling 32% of those completed. Just one of the 10 planned plants will use PEM, but it will be the first PEM stack to reach the MW scale.

The projects' end-product capacity is shown in figure 191:

- Re-electrification projects were demonstrated first and comprise more than 80% of the total. Most are of very small scale, connected to a dedicated, variable renewable plant for testing purposes;
- Chemical fuels production (methane, methanol, hydrogen-enriched natural gas [HENG] is now taking the lead, with much bigger capacities. One Canadian project might even consider producing electrolytic gasoline<sup>4</sup>; and
- 8% of the capacity of conversion projects have multiple end uses – with H<sub>2</sub> also sold to fueling stations.

**Figure 190: Non-refueling station project capacity per year<sup>2</sup>**  
MW<sub>e</sub> of electrolyzer input capacity

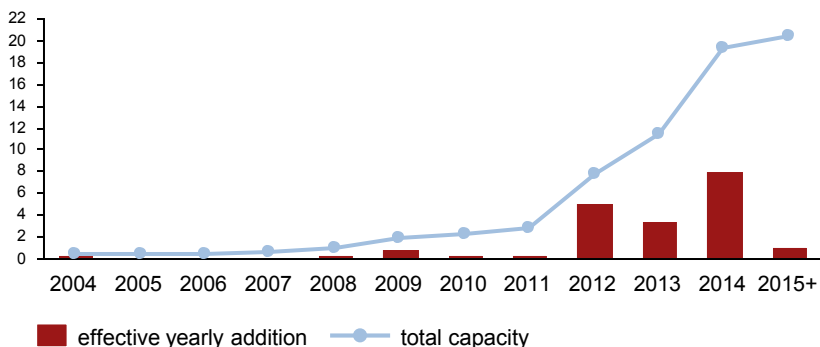

**Figure 191: Non-refueling station project capacity per end-product<sup>2</sup>**  
MW<sub>e</sub> of electrolyzer input capacity

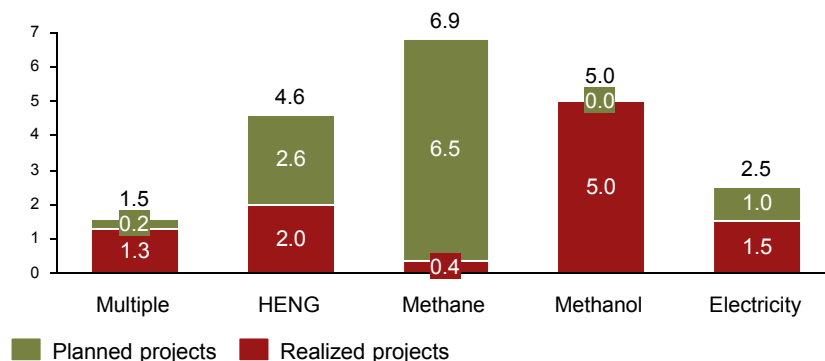

1. Commercial applications include ammonia production, hydrogen as a cooling fluid, meteorological and space applications; <sup>3</sup>Four operating and three in the planning phase; <sup>4</sup>The capacity of 43 electrolyzers for fuelling stations is unknown and the Blue Fuel Energy project, not included in analysis due to the lack of data.

# Integrated projects utilizing H<sub>2</sub> from electrolyzers are in the early demonstration phase – H<sub>2</sub> refueling stations

There are 221 H<sub>2</sub> fueling stations worldwide (and a further 20 planned), of which, 74<sup>1</sup> source H<sub>2</sub> from electrolysis (figure 192). North America and Europe are leading the way, with almost 30 projects each.

The exact capacity of a power-to-H<sub>2</sub> fueling station is hard to assess, because projects often mix electrolyzers and conventional H<sub>2</sub> production processes, such as natural gas reforming, but installed capacity is about 5.7 MW<sup>2</sup> (figure 193). Europe – and in particular Germany – is leading the demonstration of electrolytic H<sub>2</sub> fueling stations, in terms of installed capacity. But only 500 kW of electrolytic H<sub>2</sub>-refueling station capacity is planned to be built in the near future, compared with plans for 9.1 MW of P2G capacity.

The focus of integrated electrolytic H<sub>2</sub> projects is shifting away from refueling stations towards P2G opportunities, where demand prospects are greater. Re-electrification projects remain at a demonstration kW scale for now.

Figure 192: Realized electrolytic H<sub>2</sub> fueling stations<sup>1</sup>  
In number of stations

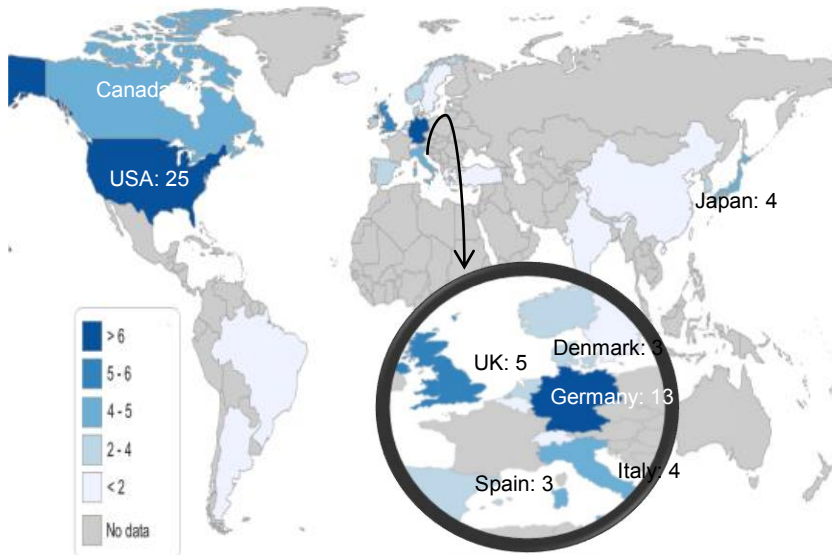
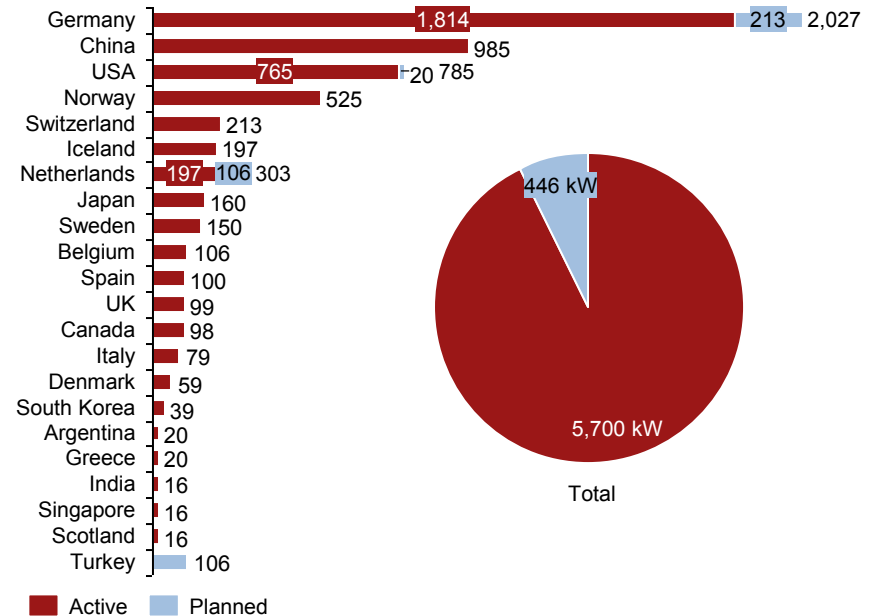

Figure 193: Realized and planned electrolytic H<sub>2</sub> fueling station<sup>2</sup>  
In electrolyzer capacity (kW)



Note: The power rating of 43 electrolyzers for fuelling stations out of 74 are unknown, and have been estimated as the first quartile of the known power range. Projects sourcing H<sub>2</sub> from electrolyzer or from a combination of electrolysis and other production process.  
Source: <sup>1</sup>U.S. DoE Hydrogen Analysis Resource Center, as of December 2012.; <sup>2</sup>Conservative estimate, based on the U.S. DoE Hydrogen Analysis Resource Center, as of December 2012.

# Project's layout (power source, location and end-product) constraints its accessible revenue sources

**Project's layout (from power source to end-product) constraints its accessible revenue sources.** The main distinctions are between: centralized and decentralized<sup>1</sup> supply to the energy-consumption site; and grid-connected or off-grid electrolyzers.

**Centralized projects** consist of a generally large-scale (>10 MW), grid-connected electrolysis plant, with no local end-use consumption site. A power grid connection to the electrolyzer is needed, even if the aim is to source electricity from a dedicated, centralized power plant<sup>2</sup>. Ideally, the connection would be to a regional electricity hub, where frequent surplus power supply creates demand for energy time-shifting or energy location-shifting applications:

- If the project includes a re-electrification system, it will benefit financially from energy time-shifting: large-scale stationary electricity storage will generate feedstock revenues paid per kWh, while shorter-term grid-stabilization is compensated according to available capacity (service revenues in kW). Combined with an intermittent power plant, the H<sub>2</sub>-based storage system would act as a firming capacity for the plant's owner, making the plant dispatchable; or.
- The project must deliver energy to the consumption site to receive energy location-shifting revenues. The energy application-shifting between electricity and chemical energy can also be monetized. For economic reasons, transport of pure H<sub>2</sub> would be kept to a minimum, with centralized conversion into HENG, methane or liquid synfuels preferable.

**Decentralized projects** (such as H<sub>2</sub> refueling station and H<sub>2</sub>-enriched biomass plants) can sometimes avoid costly delivery of chemical-energy feedstock. Another advantage is that, grid-connected electrolyzers can enable arbitrage on electricity prices (a building equipped with a grid-connected electrolyzer and a high-temperature combined-heat-and-power fuel cell can store off-peak electricity for its own heat and power needs, and participate in demand-side management). Off-grid electrolyzers are generally used in conjunction with storage and fuel cells to firm the output of the decentralized plant<sup>3</sup>.

**Figure 194: Schematic layouts of integrated projects**

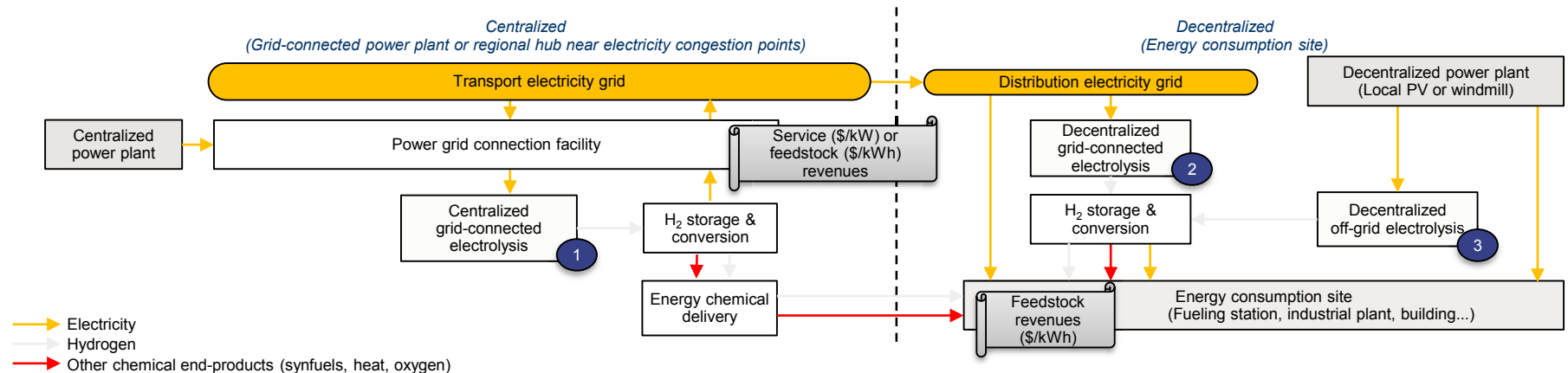

1. Also dubbed distributed, on-site, dispersed or embedded; 2This enables fully dispatchable utilization of the electrolyzer, see Section 3.2, business case No. 3; 3For example, an autonomous photovoltaic-powered telecom tower with an H<sub>2</sub>-storage system.

Source: A.T. Kearney Energy Transition Institute analysis.

# For each project layout, the optimal production profile and plant configuration are determined by the cost of input electricity and price profile of outputs

**Integrated projects have a long and complex value chain** (figure 195), consisting of: an electricity source; an electrolyzer for primary conversion; and delivery of end products. The potential selling price of end products significantly influences the production profile, particularly in the case of re-electrification. **The project's optimal configuration (component sizing and technology of choice) is, in turn, greatly influenced by the cost profile of its electricity feedstock:** continuous feedstock synfuel production could be achieved at lower costs with discontinuous electrolysis, flexible PEM stacks, and large buffer storage capacity, if electricity price variations are large. Once the configuration of the plant is known, it can be summarized by its techno-economic parameters (CAPEX, OPEX and efficiency). The levelized cost of outputs is also influenced by the owner's cost of capital and the plant's production profile.

**Figure 195: Key parameters influencing choice of plant configuration and determining project economics**

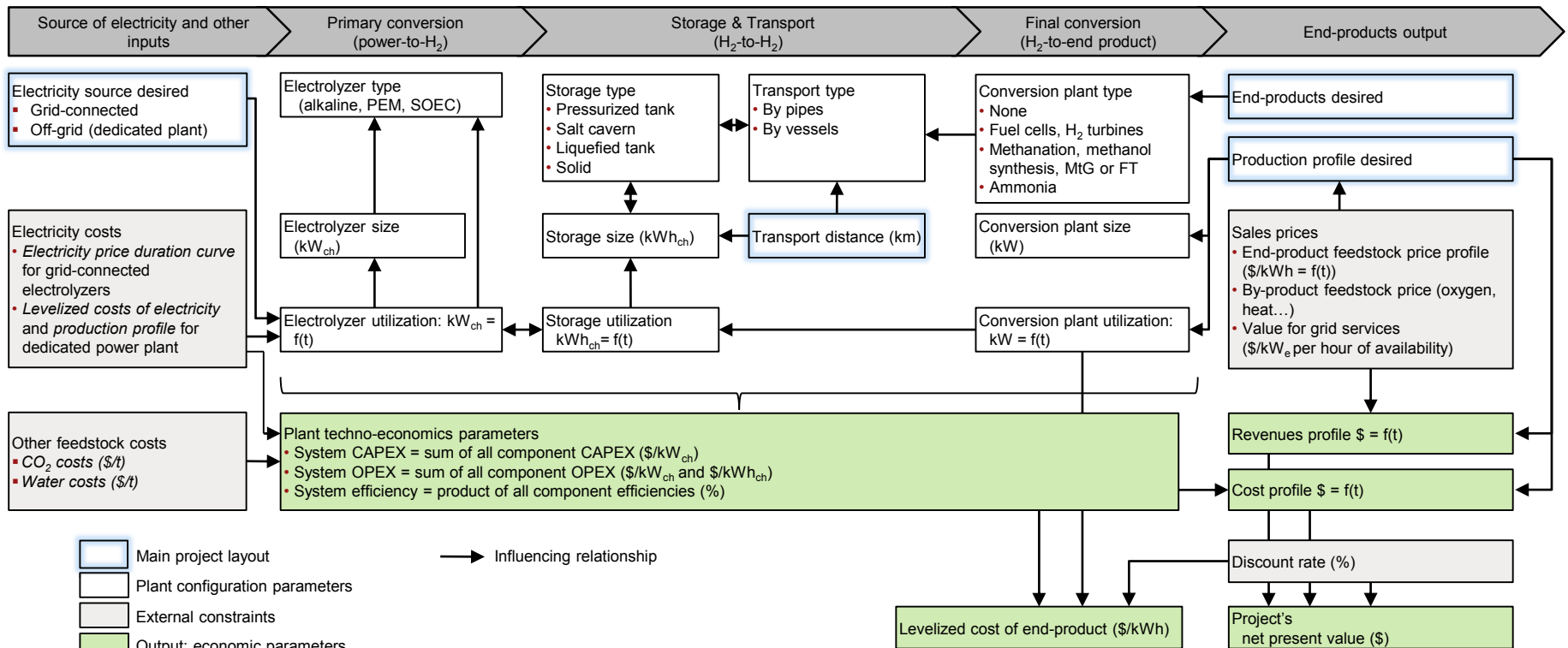

# Downstream efficiency is crucial to avoid costly oversizing of the whole value chain – for example, re-electrification projects

Integrated H<sub>2</sub> projects can have a long value chain, for which overall efficiency is determined by the efficiency of individual components. **Yet efficiency of the elements downstream in the value chain is more important than those upstream**, because efficiency losses somewhere in a linear value chain increases the need to scale-up upstream processes.

**Managing the larger upstream flow rate is more expensive.** In figure 196, two fuel cells produce 2.7 MW<sub>e</sub> in continuous operation. The one with an efficiency of 35% requires a 42% larger input flow of H<sub>2</sub> than the fuel cell with 50% efficiency. The H<sub>2</sub> storage capacity and the electrolyzer must be 42% larger. In simple terms, capital costs are usually proportional to the input flow rate. Under this assumption<sup>1</sup>, figure 196 shows how two stationary storage systems with the same round-trip efficiency can have a 15% variation in investment costs: the efficiency of the fuel cell is, therefore, more important than that of the electrolyzer.

For illustrative purpose, the levelized cost of electricity [LCOE] produced is calculated under continuous operation, with a fixed electricity price. It has no real meaning for business-opportunity analysis, because no re-electrification project would operate continuously<sup>2</sup>. **The difference in the LCOE of electricity produced (including re-electrification) of both chains is much smaller than the gap in investment costs:** H<sub>2</sub>-based electricity-storage systems have such low efficiency that electricity costs – rather than investments – determine the LCOE in baseload (at 85%).

**Figure 196: Economics of two stationary storage systems of similar round-trip efficiency, and similar specific capital costs of components<sup>1</sup>**

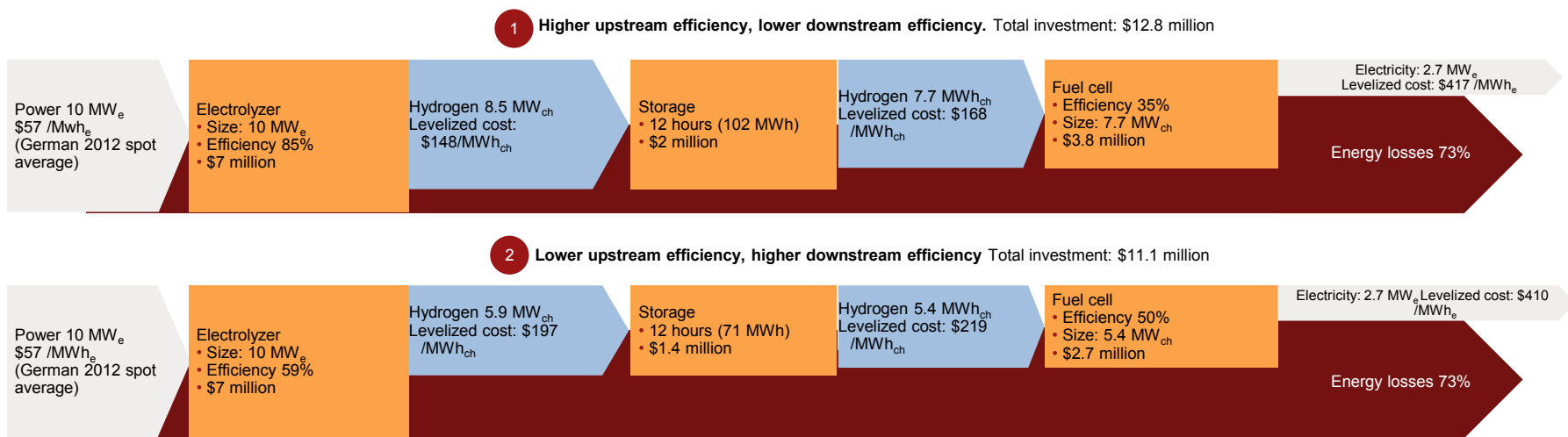

1. A.T. Kearney Energy Transition Institute analysis for illustrative purpose only, based on US DoE H2A models, with the following assumptions: electrolyzers and fuel cells have capital costs proportional to the amount of direct input energy flow: respectively \$500/kWe and \$500/kWch (arbitrary value, close to the US DoE target costs of future systems). Storage-tank costs are proportional to H<sub>2</sub> storage capacity. Its capacity is for H<sub>2</sub> storage of 12 hours at the maximum flow rate. OPEX is based on that of state-of-the-art alkaline electrolyzers. LCOH are calculated under baseload utilization.

# The production cost of chemical energy output is much higher than the electrical energy input – non re-electrification projects

Section 2.1 demonstrated that electricity-price variations in European spot markets are insufficient to deliver significant production-cost reductions with discontinuous operation of grid-connected integrated projects. Figure 197 shows the approximate levelized price of various electrolytic synfuels delivered to customers, in Germany in 2012, when operated in baseload mode. A detailed analysis of project profitability is provided in Section 3.1, but, in these examples, the price of energy is multiplied by 3.3 to 4.2 between the electrical input and chemical output. Power-to-chemical fuels would, therefore, require significantly larger price spreads between: the various forms of energy (*application-shifting* value); or locations of availability (*location-shifting* value) to ensure profitability.

**Figure 197: Order of magnitude of achievable efficiencies and levelized costs of synfuels for various integrated projects, operated continuously from the German power grid (order of magnitudes, with state-of-the-art technology, or near-term commercial target costs)<sup>1</sup>**

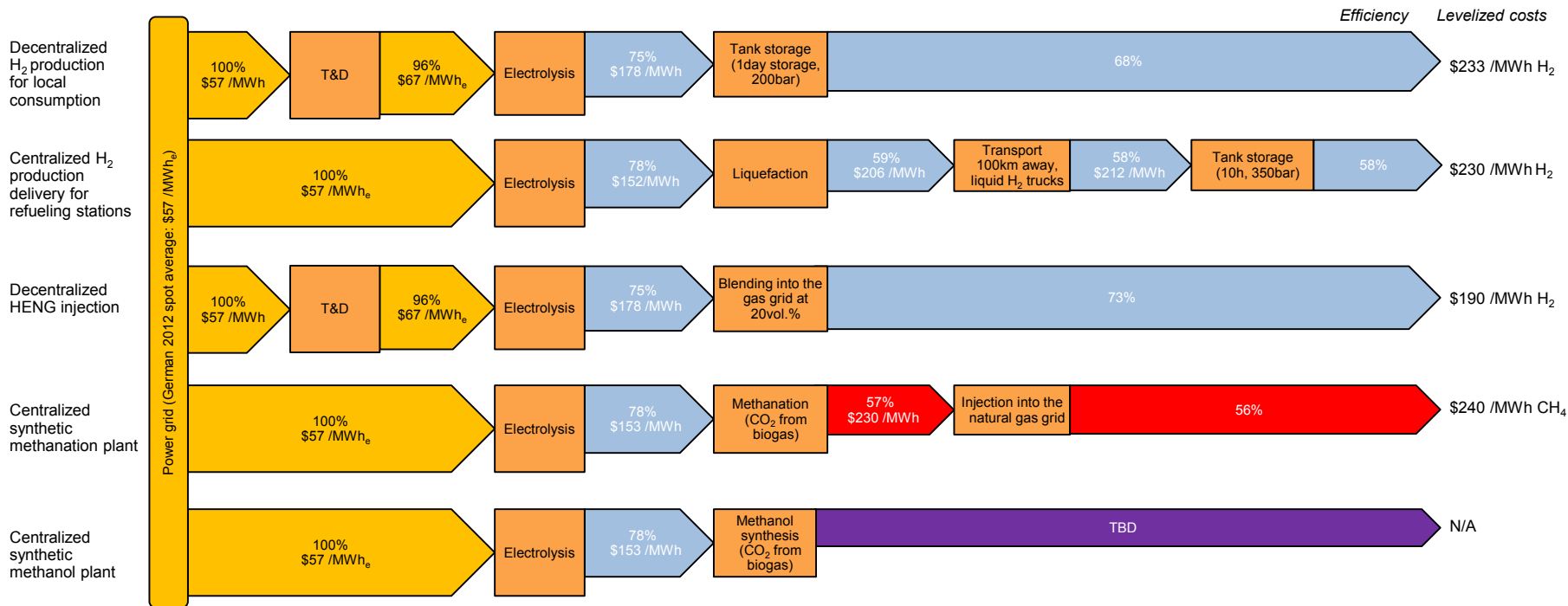

1. A.T. Kearney Energy Transition Institute analysis, based on US DoE H2A models with the following assumptions: electricity T&D costs \$10 /MWh<sub>e</sub>. for decentralized plant, natural gas costs €34/MWh; alkaline electrolyzer with CAPEX of \$733 /kWch centralized and \$861 /kWch decentralized; one-day pressurized tank storage adds \$55 /MWh<sub>ch</sub> of H<sub>2</sub>; liquefaction, transport and storage add respectively \$50, \$6 and \$22 /MWh<sub>ch</sub>; P2G efficiency reaches 57%, with CAPEX estimated at \$910/kW; blending costs 250\$ /kW injected and incurs energy losses of about 2%; discount rate: 10%. No tax.



## Integrated project ID card: Thüga Group power-to-gas project

The Thüga Group power-to-gas plant (figure 201), in Frankfurt am Main, Germany, will use an electrolyzer to convert up to 315 kW<sub>e</sub> of electricity from the grid into hydrogen to feed a gas-mixing plant in which the hydrogen in the natural gas stream never exceeds 2% by volume. The hydrogen-enriched natural gas is then injected into the local gas distribution network at network pressure, namely 3.5 bar.

The plant uses an ITM Power PEM electrolyzer that can respond to load changes within seconds and is self-pressurizing, making a compressor unnecessary. The units (picture, figure 200) benefit from a compact design (2.45 m high, 6 m long, 3.30 m wide, weighing 10 tons).

The plant, completed in September 2013, successfully injected hydrogen into the gas distribution network in December 2013. The partners are expected to invest a total of €1.5 million over the project period (2012-2016).

Plant	Thüga Group power-to-gas plant
<b>Primary energy sources</b>	<ul style="list-style-type: none"> <li>• Electricity grid</li> </ul>
<b>Electrolyzer</b>	<ul style="list-style-type: none"> <li>• 315 kW<sub>e</sub> PEM electrolyzer</li> <li>• 110% overload capacity</li> </ul>
<b>Power-to-gas plant</b>	<ul style="list-style-type: none"> <li>• 60 m<sup>3</sup> of hydrogen per hour</li> <li>• &lt;2% blending ratio in volume</li> </ul>
<b>Output</b>	<ul style="list-style-type: none"> <li>• 3,000 m<sup>3</sup> of HENG fed into the local natural gas distribution network at a pressure of 3.5 bar</li> </ul>

**Figure 200: Thüga Group power-to-gas electrolyzer plant (left) and layout (right)**



# Integrated project ID card: Audi e-gas pilot project

The Audi e-gas plant (figure 201), in Werlte, Germany, will use an electrolyzer to convert up to 6.3 MW<sub>e</sub> of electricity from wind turbines into synthetic natural gas (e-gas). The methanation unit sources CO<sub>2</sub> from a nearby biogas plant to ensure that the e-gas is carbon-neutral and renewable. Heat released by the methanation process is recycled within the plant to increase overall efficiency. Because e-gas has an identical chemical make-up to natural gas, it can be distributed through the existing gas network and used in compressed natural gas [CNG] fueling stations. It can fuel the new Audi A3 Sportback TCNG car – a certification procedure ensures sufficient e-gas is produced by the plant to fuel the Audi vehicles. The plant was due start feeding into the German gas network in summer 2013.

Plant	Etogas Beta plant/Audi e-gas project
Primary energy sources	<ul style="list-style-type: none"> <li>• Wind turbines 4*3.6 MW<sub>el</sub> nominal power</li> <li>• Electricity grid</li> </ul>
Electrolyzer	<ul style="list-style-type: none"> <li>• 6.3 MW<sub>e</sub> nominal capacity</li> <li>• 2.3 MW<sub>ch</sub> annual average H<sub>2</sub> production</li> </ul>
Methanation plant	<ul style="list-style-type: none"> <li>• e-gas production: 1,000 tons per year (1.8 MW<sub>ch</sub> average)</li> <li>• CO<sub>2</sub> consumption: 2,800 tons CO<sub>2</sub> per year</li> </ul>
Output	<ul style="list-style-type: none"> <li>• Renewable e-gas (synthetic natural gas) blended into the natural gas distribution network</li> </ul>

Figure 201: Audi e-gas pilot project

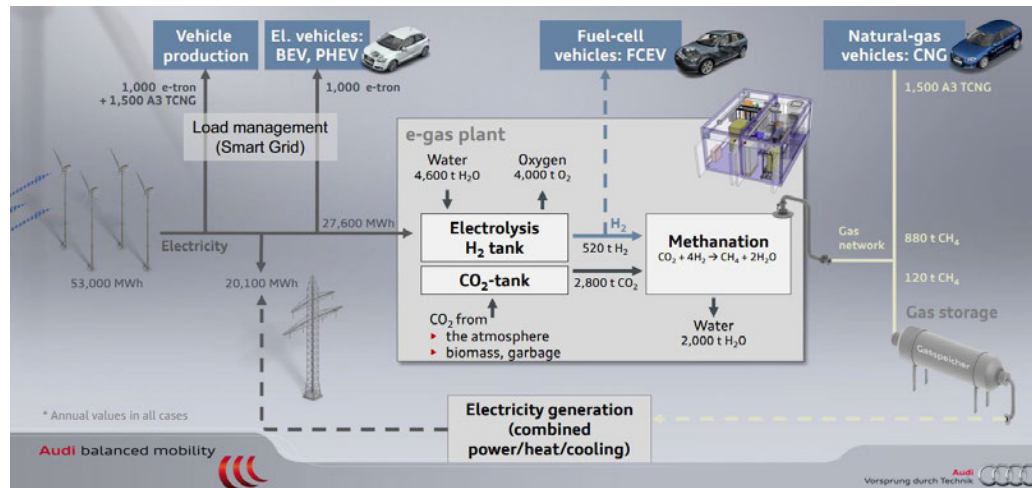

## Section 3 - Business cases



## 3.1 - Monetizing hydrogen conversion



## Summary & key findings: Section 3.1

- 1. The main challenge for hydrogen conversion is economic rather than technical.** Even if the underlying technologies are at different stages of maturity and, in some cases, are yet to demonstrate their feasibility, the technology itself does not appear to be a significant impediment to the development of electrolytic hydrogen. The main uncertainties lie in the scope for cost reductions and monetizing the benefits of hydrogen services.
  - Cost reduction is a prerequisite for commercialization. Beyond innovations that could disrupt the technology landscape (e.g. new catalysts), the principal areas of focus in engineering and manufacturing will be greater scalability and capitalizing on accumulated knowledge.
  - The benefits of electrolytic hydrogen solutions are difficult to assess and monetize. Most putative end-markets (re-electrification, blending with gas *etc.*) are virtually non-existent today and subject to the growing penetration of variable renewables. A few niche applications, such as back-up power in remote locations, could emerge in the short term, but are unlikely to develop into a mass market in which significant cost reductions could be achieved.
- 2. The versatility of hydrogen carriers opens the way to a wide range of end-uses** that valorize the conversion of power into hydrogen as a service, or the use electrolytic hydrogen as a feedstock.
  - The use of electrolytic hydrogen as a feedstock is closer to commerciality, as electrolytic hydrogen fits better in the current market structure and fetches higher end-market prices. However, in current market conditions and with the exception of a few merchant hydrogen applications characterized by very high prices (semiconductors, hospitals), support mechanisms for low-carbon solutions will still be needed. Mobility, in which hydrogen is particularly valued as a fuel, may be an application where hydrogen can compete with gasoline, but only if exempted of taxes. Hydrogen blending and methanation cannot compete with natural gas on a calorific value basis in the absence of a premium for being carbon neutral (e.g. biogas feed-in tariffs).
  - Putting conversion services into effect – such as electricity storage for price arbitrage, baseload plant optimization (e.g. maximizing utilization of the low marginal production costs of nuclear power plants) or deferred investment in the power grid – seems difficult in the near term. Providing grid services using electrolyzers for control power is a noteworthy exception. The load of electrolyzers can be increased to provide negative control power, or decreased to provide positive control power, and thus generate revenues in addition to those from feedstock hydrogen.
  - Remote areas and islands could act as testing grounds for the monetization of hydrogen services, evaluating the economics of power mixes with a high contribution from renewable energy, and the ability of such mixes to safeguard secure energy supplies. Hybrid back-up power solutions with batteries, for example, could be economic for a remote telecoms tower powered by solar photovoltaic electricity.
- 3. Difficulty in assessing the business model of hydrogen solutions is a crucial issue. This stems from three main factors:**
  - The economics of hydrogen-based energy storage solutions are inherently system- and application-specific;
  - Hydrogen solutions are all the more complex, because they involve a very high number of stakeholders; and
  - Conversion translates in a new multi-source, multi-product business paradigm that requires new optimization tools and complicates the usual modeling approach.

# The main challenge for hydrogen conversion is economic rather than technical: how to find a sustainable business case in an uncertain environment





**Most technologies in the hydrogen value-chain are proved, albeit at different stages of maturity. Cost reduction is the next prerequisite on the road to commercialization.** Besides innovations that could disrupt the technology landscape (e.g. new catalysts), the main areas of focus for engineering and manufacturing will be greater scalability and capitalizing on accumulated knowledge. For example, two chemists at the University of Calgary recently developed a low-cost catalyst made of multiple abundant metals, rather than noble metals such as platinum; this may reduce the cost of electrolysis. But other developments, such as advances in the continuous, roll-to-roll robotic processing of electrolysis cells, which avoid the need for discontinuous batch production chains, have not been dependent on one-off innovations.

**Costs are only one side of the commercialization equation. They must be balanced by revenues to achieve profitability** and there is a long way to go in this area too. Despite a large industrial market – around 53 Mt of hydrogen were consumed in 2011, according to industry data – dominated by refineries and chemicals plants, most potential end-markets for electrolytic hydrogen are virtually non-existent today (figure 202). A few niche markets are likely to emerge in the short- to-medium term, but are unlikely to provide a profitable mass market in the near future.

**Uncertainties over cost reductions and the shape of the market result in a complex business equation for hydrogen-based storage solutions.**

This section presents an overview of current thinking on hydrogen business model

**Figure 202: End-markets of electrolytic hydrogen**

	<b>Power-to-Gas</b>	Injection into the gas network is, so far, limited to feasibility studies (e.g. National Grid, ITM and Shell's project in the UK) and field pilot plants (e.g. E.ON's 360 m <sup>3</sup> /h hydrogen injection in Falkenhagen). Hydrogen feedstock used for biogas and biofuel plants is also restricted to the up-scaling pilot plants in Germany (e.g. Etogas and the Audi 6 MW project in Werlte).
	<b>Power-to-Mobility</b>	Mobility applications are constrained by infrastructure in place, which consists, as of 2012, of 221 active refueling stations worldwide – of which 74 source hydrogen from electrolysis – supplying around 650 demonstration fuel-cell-electric vehicles and 3,000 forklifts. There are also a small number of compressed natural gas stations equipped with hydrogen-blending facilities, in Norway, Sweden, US, France or Italy.
	<b>Power-to-Power</b>	Re-electrification, despite the promising increase in fuel-cell shipments, remains at a nascent stage and is still mainly driven by portable applications such as toys or consumer electronics. Recent announcements from hydrogen manufacturers (e.g. Hydrogenics, Proton OnSite) indicate that the first integrated module (electrolysis, storage and fuel cell) may yet provide an outlet for off-grid power or grid support. At this stage, there is no long-term storage project in the pipeline.
	<b>Power-to-Industry</b>	The merchant hydrogen market supplying industrial needs (e.g. healthcare, space industry, semiconductor fabrication, power plant generator cooling, meteorological monitoring) is growing and may generate higher prices in the short term for customers looking for high purity and small volumes of hydrogen. Coupling an electrolyzer with a wind farm or with solar PV cells close to end-demand may provide markets for the first stand-alone business cases.

Note: See MIT Technology Review (<http://www.technologyreview.com/view/512996/a-cheaper-way-to-make-hydrogen-from-water/>); Fuel cell shipments reached 100 MW for the first time in 2011; Horizon Fuel Cell Technologies also sent a positive signal by buying ITM's sales and marketing rights for small-scale electrolyzers in some Asian countries.

Source: A.T. Kearney Energy Transition Institute analysis, based on Berlinguette et al (2013); FuelCellToday (2012); Image courtesy of (top to bottom): E.ON, CUTE, ReliOn, The Linde Group.

# The versatility of the hydrogen carriers opens the way to a wide range of end-uses that valorize the power conversion to hydrogen as a service or the hydrogen produced as a feedstock

The conversion of surplus variable renewable energy into hydrogen may be monetized through very different revenues streams. These monetization options can be grouped into two main categories (figure 203), depending whether they valorize:

- Hydrogen produced as a feedstock for final energy or chemical uses (e.g. feedstock for biogas companies to upgrade their production by recycling excess carbon; feedstock for the petrochemicals industry to desulfurize sour crude oils; and feedstock for fuel cell electric vehicles etc.); or
- The conversion of intermittent energy and optional storage as a service (e.g. by avoiding the need to shut down baseload power plants, or curtailing wind power, ensuring power quality with a negative reserve, making gas networks greener etc.)

**Water electrolysis by-products are a third group of potential revenues**, mainly through selling oxygen produced in the course of the water splitting ( $H_2O$  into  $H_2$  and  $O_2$ ), but also by using the heat generated in the process<sup>1</sup>.

**Figure 203: Examples of direct revenue streams from the conversion of intermittent-source electricity into hydrogen**

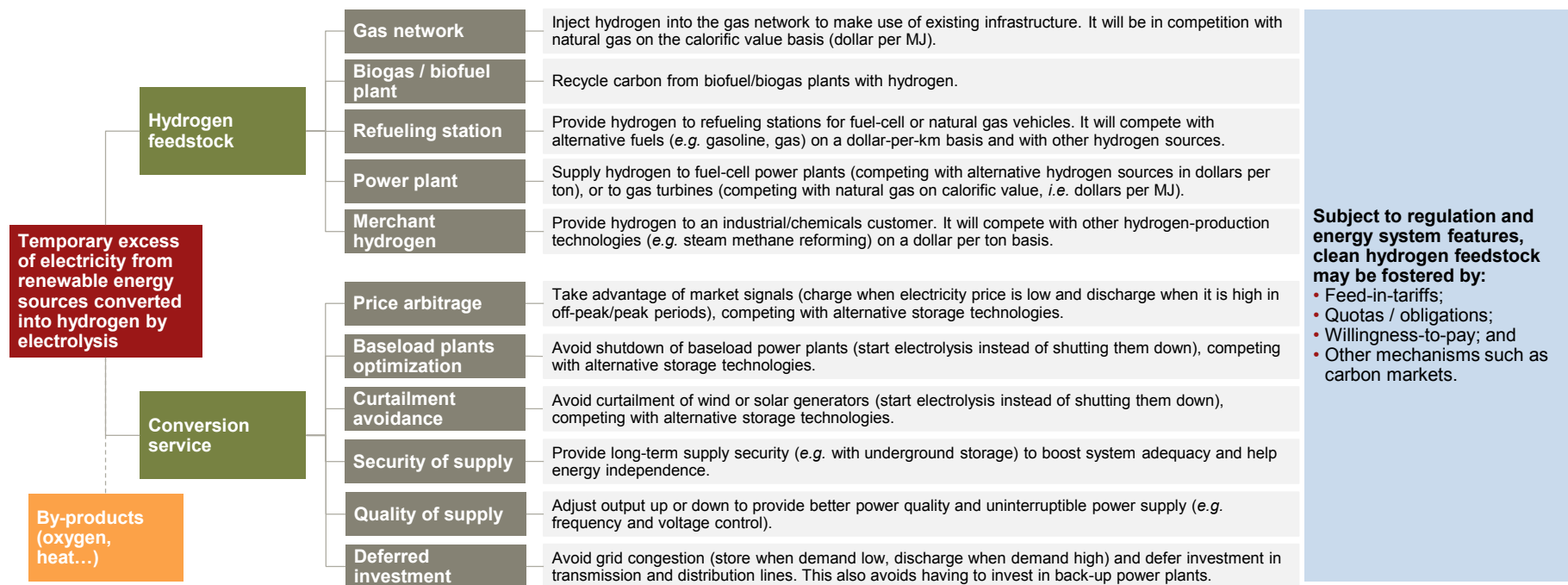

1. Hydrogen re-electrification in a fuel cell may also sell the water generated in the process. It has not been considered in this study as this water may be used for the electrolysis operations.  
 Source: A.T. Kearney Energy Transition Institute analysis.

# Applications that valorize hydrogen as a feedstock and benefit from support mechanisms for low-carbon solutions are likely to drive the first hydrogen energy developments

In the short term, hydrogen is likely to be valorized as a feedstock (figure 204). Feedstock hydrogen fits well into current market structures and provides the highest value, counterbalancing production costs.

- The highest prices for hydrogen are likely to be achieved on the merchant **hydrogen market for industrial applications**. Depending on the purity, the volume, the contract length and natural gas market price, merchant hydrogen distributed in cylindrical pressure tanks is sold for around \$8-15 /kg (\$203-381 /MWh) to large industrials, with a significant premium charged for very small quantities.
- Target prices for **mobility applications** (renewable methanol, hydrogen fuel for fuel cells) are also attractive, as they take as reference gasoline prices, including taxes and VAT. In Europe, a reference retail price of gasoline at €1.6 /Liter would correspond to a target price of around €10 /kg of H<sub>2</sub> (*i.e.* \$254 /MWh), according to Air Liquide. This may compensate, in some cases, for the full cost of producing and storing electrolytic hydrogen. Making hydrogen tax-free amounts to a hidden support mechanism, assuming that hydrogen is carbon neutral.
- **Power-to-gas applications** are currently likely to be hindered by the low price of natural gas. In several countries, feed-in tariffs exist for biogas that could help the business model for hydrogen blending or upgrading a biogas plant (*e.g.* €45-125 /MWh in France, depending on size). Success depends on how hydrogen is able to benefit from green tariffs.
- **Power-to-power applications** are not yet valuable end-markets, given average wholesale prices ranging from around \$60-70 /MWh, even when operations are optimized (see Section 2.1). Services such as grid deferred investment or variable renewable firming could be appealing, but will struggle to compete with alternative storage technologies, such as pumped hydro storage, batteries or compressed air energy storage.

Electrolytic hydrogen may also struggle to compete with hydrogen produced from steam methane reforming (roughly \$30-150 /MWh using carbon-neutral natural gas).

Figure 204: End-market prices for hydrogen feedstock in Germany vs. natural gas in \$/MWh adapted from E.ON<sup>1</sup>

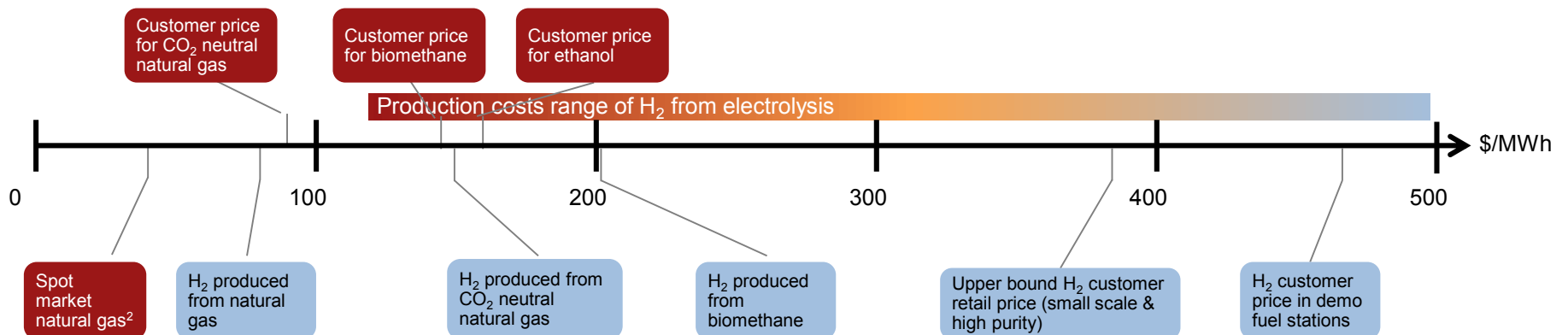

1. Based on E.ON (2013) analysis presented by Dr. Andreas Kopp at the "H2 in the economy" European Commission workshop. Prices have been converted from €/kWh to \$/MWh to improve ease of understanding of the report using a €/€ conversion rate of 1.31; <sup>2</sup>Spot price on NetConnect Germany(NGC) market area. Source: E.ON (2013); Troncoso (2011).

# Providing grid services with electrolyzers for control power could provide additional revenues to those generated by green merchant-hydrogen production

In the current market, the cost of hydrogen production from grid-connected electrolyzers is minimized when electrolyzers are operated continuously (see Section 2.1). This is largely explained by the combination of insufficient average price spreads and high up-front capital costs. In other words, extreme price events are not frequent enough to counterbalance the beneficial effect of the utilization rate on amortization. In this paradigm, hydrogen production from renewables will principally be remunerated for the feedstock value of hydrogen, together with a green premium when support mechanisms are in place.

However, there are opportunities for electrolyzers to provide grid services and to generate additional revenues by participating in a balancing market (figure 205). Electrolysis can, of course, provide positive-control power by decreasing its load from its normal operating level (100%) to zero. Electrolysis can also provide negative-control power by increasing its load above that of normal operations. This is explained by the fact that the nominal load (100%) is not the maximum load, but the load that optimizes the electrolyzer's performance (current density & cell voltage, see Section 2.1). Higher current density can be applied temporarily to increase load above the nominal value, at the expense of the cell's efficiency and lifetime. As long as these drawbacks are minor compared with the advantages of providing negative-control power, it is possible for electrolysis to operate at a higher load than nominal conditions, up to a very high level.

Bundling hydrogen production applications with grid services from control power is expected to be a promising business model (see section 3.2, Business case No.1). For instance, according to models from the French Alternative Energies and Atomic Energy Commission, operating electrolysis while participating in the balancing power market would reduce the levelized cost of hydrogen production by 9%, under 2010 market conditions in France (figure 206). In addition, proponents of proton exchange membrane [PEM] electrolyzers, including Siemens, point out that PEM electrolyzers provide superior dynamic load-control to alkaline cells. They also highlight their superior response time and ability to cycle from 0% to 300% without a significant impact on ageing.

Participation in control power will probably be the first application in which hydrogen solutions will be remunerated for services, rather than for feedstock value.

Figure 205: Illustration of electrolysis operation as control power

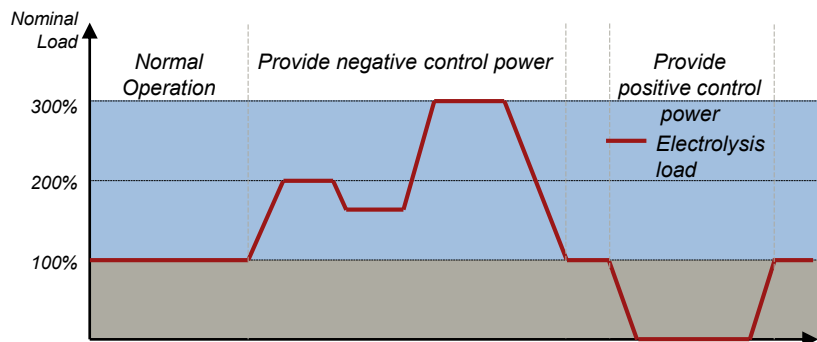

Figure 206: Operating characteristics for hydrogen production with and without participation in the balancing market (France 2010 EPEX prices)

	Continuous operation with no participation to balancing Market	Operation with participation to balancing Market
Annual utilization rate (hours equivalent at nominal load)	8,760 (100%)	5,588 (64%)
Longest period operating at nominal load (h)	8,760	133.5
Longest period operating at minimum load (h)	0	53.5
<b>Levelized Cost of Hydrogen<sup>1</sup></b>	<b>\$103 per MWh<sub>ch</sub></b>	<b>\$96 per MWh<sub>ch</sub></b>

1. Based on result in €/kg, translated using a €/€ conversion rate of 1.31 and a kg/MWh<sub>ch</sub> conversion of 39.39. Source: Adapted from Siemens (2013) and Mansilla et al. (2012).

## Remote areas and islands could act as testing grounds for the monetization of hydrogen services, which are unlikely to be profitable in well-connected areas in the short term

**Remote areas** – *i.e.* communities not connected to central energy infrastructure<sup>1</sup> – **lead the way in using storage in conjunction with renewable energies.** In most cases, energy prices are, on an unsubsidized basis<sup>2</sup>, significantly higher in these areas due to additional transportation costs and limited infrastructure. This makes it easier for renewable energy to compete. However, the penetration of variable renewables is partly restrained by the lack of flexible energy sources. As a result, despite generation costs in the \$250-300 /MWh range, diesel generators provide a large proportion of electricity on many islands.

**Storage solutions focusing on combining batteries with Solar PV have been studied in several locations.** This is because there are many tropical islands with 1,000-10,000 inhabitants where mini-grids could work well and where batteries complement the diurnal pattern of Solar PV (1,200 islands have been identified, with a total 3.9 million inhabitants and 8 GWh of storage potential). Most studies conclude that, for solar irradiance of around 2,000 kWh/m<sup>2</sup>/y, hybrid PV batteries can be competitive with diesel generation when diesel prices are close to or above \$2 per liter.

**In this paradigm, hydrogen solutions could work with batteries to increase reliability and provide additional flexibility.** Hydrogen technologies can complement battery storage by removing the need for back-up generation when a very high reliability level is required (e.g. military installations, emergency response centers, mining *etc.*), minimizing the replacement costs of batteries by preventing deep-discharge and increasing sizing flexibility by decoupling energy and power. They can also absorb a seasonal swing of supply and valorize temporary excesses of power outside the electricity sector for end-uses in mobility, heating and cooling, and even in small-scale fertilizer production (see Section 2.7). This will be tested in the Ecoland project in the UK (figure 207), building on prior experience in Utsira in Norway (see Section 3.2, business case No. 6).

**As highlighted by the IEA in its Renewable Energies for Remote Areas and Islands report: “Remote areas provide promising locations to evaluate the economics of high-penetration scenarios, potentially shedding insights for larger countries with ambitious renewable energy targets”.**

Figure 207: The role of the hydrogen energy carrier in the Ecoland project, Isle of Wight (UK)

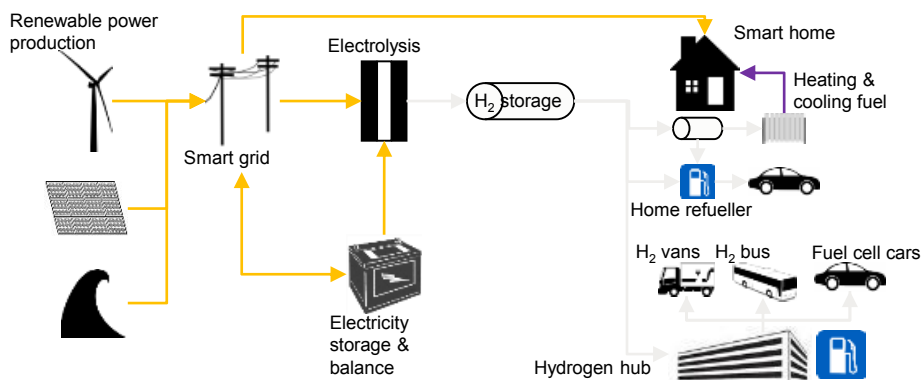

### ECOLAND PROJECT

- Ecoland aims to make the Isle of Wight fully renewable by 2020 and a net exporter to the UK mainland. Here, hydrogen will be used as an energy storage medium and as a fuel for mobility. The UK Technology Strategy Board has awarded a \$7.5 million grant to build the infrastructure. In a second stage, temporary excesses of electricity produced from renewable energy sources could be exported to the UK by injecting it into the gas network.
- Electrolyzers will act as demand-side management, converting temporary excesses of electricity into hydrogen. Two refueling platforms will be installed with 350 bar and 700 bar capability (one of 3,939-4,923 MWh<sub>ch</sub>/day, one of 590 MWh<sub>ch</sub>/day).
- Project stakeholders include Toshiba for the energy management system and balance, IBM for smart appliances, ITM Power for hydrogen solutions and SSE for grid connections.

1. Remote areas include islands, remote communities (e.g. mining sites) and stranded grids (e.g. military camps or emergency response centers) that have to run autonomously; 2. In several remote locations, energy prices are subsidized (e.g. prices are similar in French overseas island to those on the mainland).; Source: Diesel generation costs range are derived from IEA-RETD (2012); IRENA (2012); Younicos (2011); Raj (2012), Blechninger et al. (2012); Ecoland (www.eco-island.org).

# Hydrogen conversion solutions are made more complex because they involve many stakeholders

Reflecting the complexity of the hydrogen technical value chain, **numerous stakeholders interact in hydrogen conversion, storage and end-uses** (figure 208). As illustrated below, for power-to-gas in Germany, hydrogen business models combine the legal, political and market elements of the power, gas and merchant-hydrogen fields.

**This complexity may be an impediment to hydrogen conversion**, as it could dissuade small players from investing. Biogas producers or renewable generators may want to avoid greater participation, due to the transaction costs necessarily involved. Simplifying and clarifying processes and regulation is therefore essential to make the conversion business model attractive (see Section 5).

**Figure 208: Simplified stakeholder interactions in power-to-gas pathways in Germany**

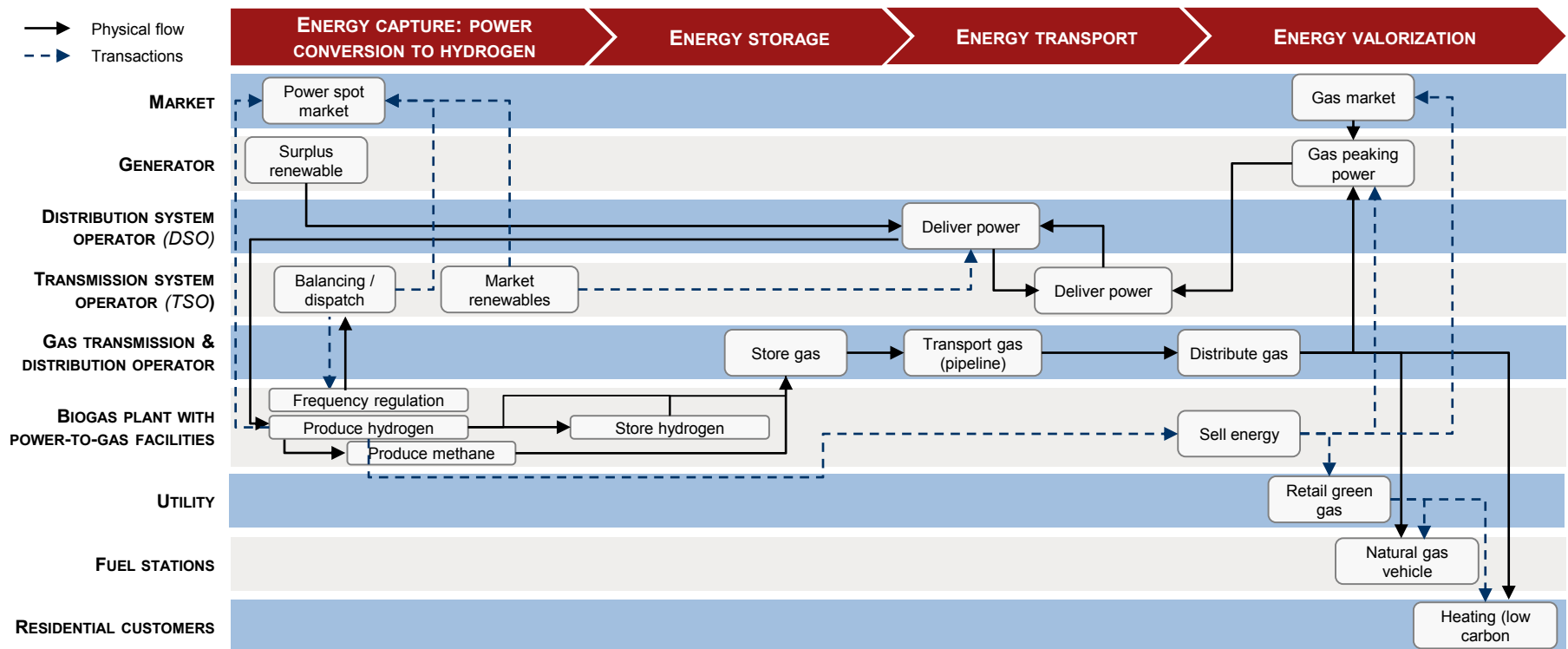

Feed-in-tariff compensation depends on all systems. In Germany, renewable electricity benefiting from priority dispatch is usually feed into the distribution network. It is then transmitted to TSO for sale on the spot market, where utilities purchase the electricity to send to end-consumers.

Source: A.T. Kearney Energy Transition Institute analysis, based on Hydrogenics (2012); Brandstätt et al. (2011).

# Conversion is the basis for a new business paradigm: from single-source single-products to multi-source multi-products that require R&D to develop optimization-modeling tools

**Energy systems are mainly based on a simple model, where one source of energy is transformed into another form to meet demand (figure 209).** For instance, natural gas is transformed into electricity in a gas turbine, or hydrogen via a reformer. In this model, by-products generated in the course of conversion, mainly heat – but also oxygen, for instance, in an electrolyzer – are considered as waste, and lost. This model also applies to the long-established practice of flaring natural gas during oil processing.

**In order to address the decarbonization challenge, energy systems have started to move towards single-source multi-product and multi-source single product templates.** The main example of the single source multi-product system is heat and power co-generation, where excess heat generated during electricity generation, otherwise lost in cooling water, is recovered and used to supply district heating networks or as process heat in industry. Multi-source single-product systems have also emerged to make existing infrastructure greener. Good examples are biomass co-firing in coal power plants, or the use of gas or coal as a back-up in concentrated solar power plants to increase utilization of the power generation block.

**The versatility of the hydrogen carrier and its role as an energy bridge between power, heat, gas and liquid carriers open the way to multi-source multi-product energy systems.** In such a system, it is possible to arbitrage between several inputs and several outputs to take advantage of price signals, notably those arising from intermittent primary sources, demand variations or external events.

**But there is a serious lack of modeling tools for taking advantage of this new flexibility.** The numerous inputs and outputs that exist require multi-dimensional optimization tools, which are, at present, lacking in the energy sector. Academic advances, despite recent efforts, are less advanced on the economic and financial side than on the technical side. A large effort is therefore essential to develop the modeling dimension (both macro for energy models such as TIMES, or micro for utilities, investors or generator management).

**Figure 209: Illustration of energy system layout from single-source single-product to multiple-source multiple-product**

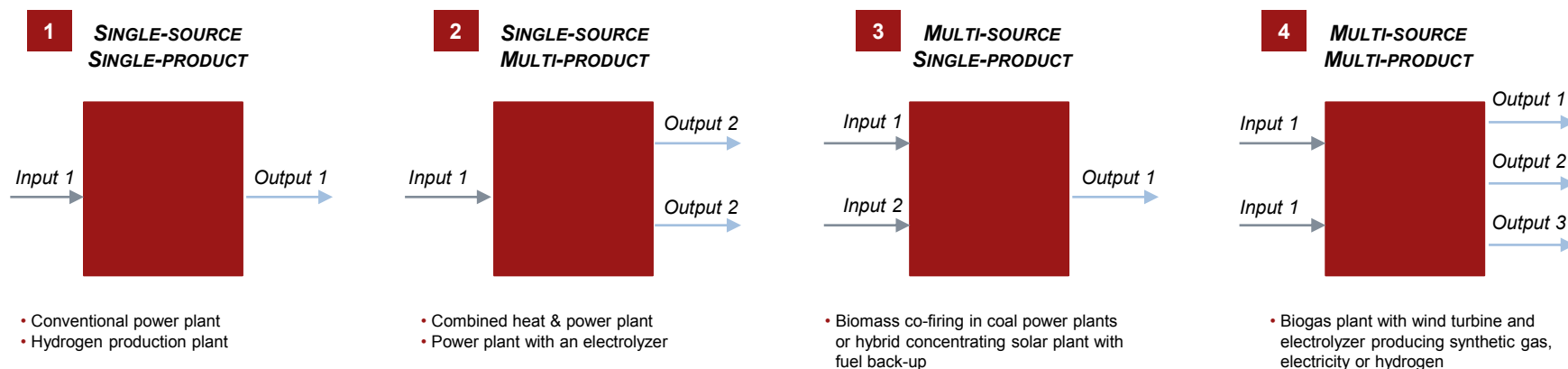

# The business models of electrolytic hydrogen solutions are inherently system- and application-specific

**This section mainly aims to provide an understanding of various possible hydrogen-storage business cases:** the revenues hydrogen storage could generate; and the preferred options for commercialization at present. The latter category is based on prevailing market conditions and estimates derived from illustrative business cases, and identifies key factors to be monitored, as well as gaps in modeling tools.

**The economics of hydrogen-based energy storage are inherently system- and application-specific.** System and application conditions significantly affect the competitiveness of hydrogen both in terms of cost and revenue. For instance, in the case of power-to-power applications dedicated to compensating for the intermittency of wind and solar PV farms, the correlation of the power consumption curve with production profiles (e.g. in a sunny country, where peak demand, derived from air-conditioning, matches peak solar PV output) is likely to flatten the electricity price, driving up the cost and reducing revenues from hydrogen.

**Investors, policy-makers and decision-makers, therefore, need to assess how appropriate hydrogen-based solutions are compared with the alternatives, in the context of local, application-specific conditions.** In other words, it is not possible, based on business cases found in academic literature, commercial documentation or in this presentation, to make conclusions about the relevance of hydrogen options without adjusting the set of hypotheses to the environment under consideration. Storage modeling must be done at a very high level of detail in the dimensions of time and space to be useful (probably intervals of minutes at the power and gas-grid-node level) and this remains a real challenge for the industry. So the slides in the next section must be treated with caution and should not be used to reach definitive conclusions about the business case for hydrogen.

**Figure 210: Power system and application factors influencing hydrogen business cases**

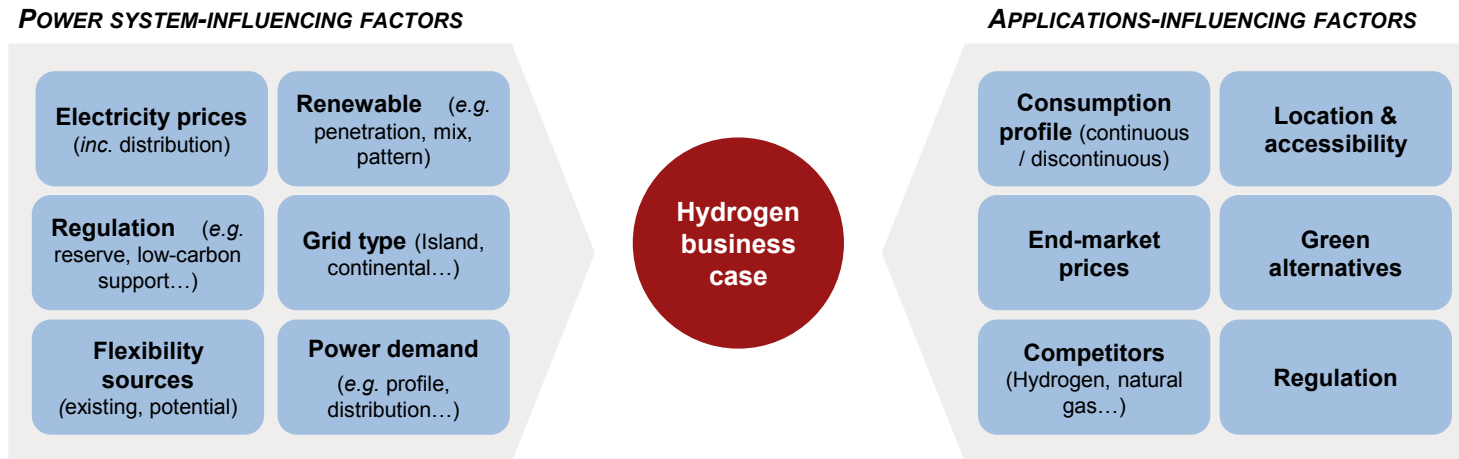

## Sources: section 3.1

- Berlinguette et al. (2013), *“Photochemical route for accessing amorphous metal oxide materials for water oxidation catalysis”*, Curtis Berlinguette, Rodney Smith, Mathieu Prévot, Randal Fagan, Zhipan Zhang, Pavel Sedach, Simon Trudel, Man Kit Jack Siu, *Science*, vol. 340, pp. 60-63
- Blechinger et al. (2012), *“Energy storage systems for renewable island systems – an enormous global market potential”*, Philipp Blechinger, Enrico Howe, Catherina Cader, Guido Plessmann, Markus Hlusiak, Robert Seguin, Christian Breyer, Reiner Lemoine Institute, Proceedings of International Renewable Energy Storage (IRES) Conference 2012 in Berlin
- Brandstätt et al. (2011), *“How to deal with negative power price spikes? Flexible voluntary curtailment agreements for large-scale integration of wind”*, Christine Brandstätt, Gert Brunekreeft, Katy Jahnke, *Energy Policy*, vol. 39, pp. 3732-3740
- E.ON (2013), *“H<sub>2</sub> in the economy - The strongest link in the energy chain?”*, European Commission Workshop Proceedings, [http://ec.europa.eu/energy/technology/events/20130426\\_h2\\_in\\_the\\_economy\\_en.htm](http://ec.europa.eu/energy/technology/events/20130426_h2_in_the_economy_en.htm)
- FuelCellToday (2012), *“The fuel cell industry review 2012”*
- FuelCellToday (2013), *“Water electrolysis & renewable energy systems”*
- He et al (2012), *“Evaluation indicators for energy –chemical systems with multi-feed and multi-product”*, Chang He, Xiao Feng, *Energy*, vol. 43, pp. 344-354
- Hemmes et al. (2007), *“Towards multi-source multi-products energy systems”*, Kas Hemmes, Leslie Zachariah-Wolff, Martin Geidl, Göran Andersson, *International Journal of Hydrogen Energy*, vol. 32, pp. 1332-1338
- Hydrogenics – (2012), *“Power-to-gas: technology and business model progress”*, Proceedings of the IPHE Conference in November 16<sup>th</sup> Sevilla Workshop
- Institut Français du Pétrole Energies Nouvelles – IFPEN (2012), *“L’hydrogène, carburant de l’après-pétrole?”*
- International Energy Agency – IEA (2012), *“World Energy Outlook 2012”*
- International Energy Agency - Renewable Energy Technology Deployment – IEA-RETD (2012), *“Renewable energies for remote areas and islands (REMOTE)”*
- International Renewable Energy Agency – IRENA (2012), *“Electricity storage and renewables for island power – A guide for decision makers”*
- Mansilla et al. (2012), *“Electric system management through hydrogen production – A market driven approach in the french context”*, Christine Mansilla, Jeremy Louyrette, Sandrine Albou, Cyril Bourasseau, Nathalie Collignon, Séverine Dautremont, Julien Martin, Françoise Thais, *International Journal of Hydrogen Energy*, vol. 37, pp. 10986-10991
- Siemens (2013), *“H<sub>2</sub> in the economy - The strongest link in the energy chain?”*, European Commission Workshop Proceedings, [http://ec.europa.eu/energy/technology/events/20130426\\_h2\\_in\\_the\\_economy\\_en.htm](http://ec.europa.eu/energy/technology/events/20130426_h2_in_the_economy_en.htm)
- SMALLEST (2008), *“Promoting Unst Renewable Energy (PURE) project. Copenhagen”*
- Troncoso et al. (2011), *“Electrolysers for mitigating wind curtailment and producing ‘green’ merchant hydrogen”*, Enrique Troncoso, Marcus Newborough, *International Journal of Hydrogen Energy*, vol. 36, pp. 120-134
- Younicos (2011), *“Switching off the generator – the stable operation of sustainable island grids in the MW range using renewable energy and energy storage”*

## 3.2 - Selected business cases

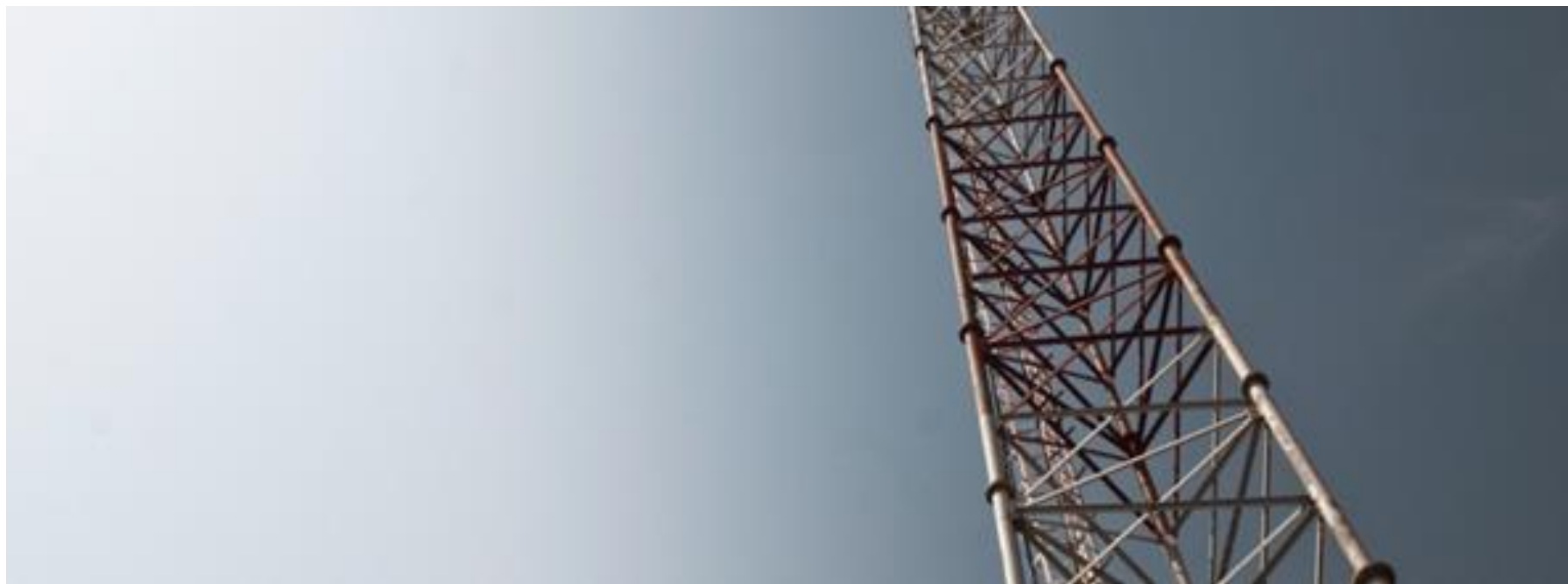

## Summary & key findings: section 3.2

**Methodology.** Nine business cases have been selected to cover the large variety of applications technically applicable to electrolytic hydrogen production. Due to the highly sensitive nature of already uncertain system parameters, care should be taken in extrapolating conclusions beyond their defined scope. The first five cases involve selling chemical energy feedstock. Their profitability is fundamentally based on the existence of price spreads between electricity input ( $\$/\text{kWh}_e$ ) and energy-carrying chemicals output ( $\$/\text{kWh}_{\text{ch}}$ ), which must be large enough to compensate for the capital invested and energy losses. The last four cases involve the sale of electrical energy (pure electricity storage); in these cases, hydrogen is only a storage medium for energy time-shifting purposes.

### Summary:

- 1. Optimization of hydrogen production costs through the use of price arbitrage both on the spot and balancing electricity markets for grid-connected electrolyzers.** A wise utilization strategy for grid-connected electrolyzers can reduce the levelized cost of hydrogen production if a price arbitrage strategy on the spot market is combined with participation in the balancing market for power reserves (9% reduction in France, 2010). Yet the variability of spot prices – which increases price-arbitrage opportunities – has not been clearly correlated with the penetration rate of variable renewables in the grid so far.
- 2. Hydrogen-enriched natural gas from grid-connected electrolyzers with various wind-penetration scenarios in Denmark.** The wind penetration rate and variability of the spot price of electricity have been correlated in the past in western Denmark. When extrapolating these correlation trends for higher wind penetrations and calculating the lowest levelized cost of hydrogen production with spot-price arbitrage, it was found that electrolytic hydrogen might never compete with fossil-based natural gas, or only in cases when wind penetration exceeds 75% and feed-in tariffs for hydrogen injected are equivalent to those for biogas today.
- 3. Liquid hydrogen production and delivery to refueling stations from a dedicated wind power plant in the US.** 100% renewably produced  $\text{H}_2$  can be delivered at  $\sim \$2.9$  /Liter of gasoline equivalent [Lge]. Unless the cost of wind turbines drops and that of fossil fuel rises, natural gas reforming would be a cheaper alternative for producing hydrogen. However, in this case, the  $\text{H}_2$  would not necessarily be carbon.
- 4. Production of synthetic natural gas [SNG] for compressed natural gas vehicles in Sweden.** Sweden imposes high fossil-fuel taxes and has an electricity grid with a very low  $\text{CO}_2$  intensity. This creates an appealing price spread between natural gas and electricity that can make power-to-methane projects profitable if SNG is sold exclusively for mobility purposes. The proposed project has a 16% internal rate of return [IRR] and a synthetic natural gas break-even sale price of  $\text{€}1.2$  /Lge, but remains very risky.
- 5. Synthetic methanol production from electricity and various carbon sources in Denmark.** Methanol synthesis costs can be halved and project risk reduced if the feedstock energy used is not only electricity, but also biomass or natural gas, or a combination of both. Electrolyzers have an important role to play in bringing the cost of renewable synthetic methanol closer to that of commercial (fossil-based) methanol.
- 6. Back-up system for reliable power supply to remote communities powered by renewables and diesel imports.** Four pilot projects have demonstrated the feasibility of reducing or avoiding diesel imports thanks to hydrogen-based storage systems, assisted by public funding. However, further cost-reductions are needed before hydrogen can displace diesel imports economically.
- 7. Autonomous system for off-grid, photovoltaic-powered telecoms towers in remote locations.** kW-scale  $\text{H}_2$ -based storage systems will be a cost-effective alternatives to diesel back-up generators in India by 2015, where the potential market size for such systems should reach at least  $\$8.4$  million to  $\$16$  million per year

## Summary & key findings: section 3.2 continued

8. **Bulk electricity storage for inter-day price arbitrage.** One potential application for H<sub>2</sub>-based storage systems is to operate daily cycles with relatively large power and energy capacities in order to benefit from peak/off-peak electricity price spreads. Such opportunities are very limited at the moment, each new price arbitrage capacity installed having a tendency to destroy its own business model by reducing price differences. Hydrogen may be able to compete with batteries for daily cycling in the near future, but not with compressed air energy storage or pumped hydro in locations that are suitable for these technologies.
9. **Long-term, grid-scale electricity storage in the German Energiewende.** There might be no need for large-scale storage systems in Germany where the penetration of renewables in the electricity mix is below 50%, other than for pumped hydro. Above 50%, H<sub>2</sub> should be the best storage option.

# Nine business cases illustrate the profitability of various electrolytic hydrogen projects

**Nine business cases have been selected to cover the large variety of applications technically accessible to electrolytic hydrogen production.** All except one are studied from the point of view of the owner of the project in the present or near future, in order to give an idea of the conditions under which H<sub>2</sub>-based systems could be profitable. A long-term macro view of future energy systems is discussed in the last case study. All case studies are based on recently published and trusted scientific literature, and are interpreted and synthesized in a few slides to allow for easy comparison. The full set of assumptions and sources are detailed in an introductory slide for each case study. Table below summarizes the 9 cases studied: The first five cases involve selling chemical energy. Their profitability are fundamentally based on the existence of price spread between electricity (\$/kWh<sub>e</sub>) and energy chemicals (\$/kWh<sub>ch</sub>), large enough to compensate for the capital investments and energy losses in the conversion. The last four cases involve selling electricity, and hydrogen is only used as a time-shifting storage medium and not as energy carrier. Six of the cases have grid-connected electrolyzers while the rest have plants dedicated to green electricity supply. Due to the variety of end-use products and the highly sensitive nature of sometime uncertain system parameters, care should be taken in extrapolating conclusions drawn from those cases studied beyond their defined scope. Some potentially important business cases are omitted in this selection, namely: synthetic gasoline/diesel, electricity storage for fast response frequency regulation, decentralized hydrogen production for mobility fleets such as forklifts or hydrogen buses. A.T. Kearney Energy Transition Institute's consolidated opinion and outlook on electrolytic hydrogen applications are presented in (Section 5).

Case study	Market	Energy source	Project size	H <sub>2</sub> storage/ H <sub>2</sub> transport	Country, year
1 Optimization of electrolytic hydrogen production costs with price arbitrage strategy on both spot and balancing electricity market	N/A (raw H <sub>2</sub> undelivered)	Power grid	125 MW <sub>e</sub>	No No	French, Spain and Germany, 2012
2 Hydrogen-enriched natural gas a from grid-connected electrolyzer with various wind penetration scenarios in Denmark	HENG (+ O <sub>2</sub> sales)	Power grid	5 MW <sub>ch</sub> H <sub>2</sub>	No No	Denmark, future scenario
3 Liquid hydrogen production and delivery to refueling stations from a dedicated wind power plant in the US	Liquid H <sub>2</sub> for refueling station	Dedicated wind farm	65 MW <sub>ch</sub> H <sub>2</sub>	Yes (week) Yes (road)	US, 2011
4 Synthetic natural gas production for compressed natural gas vehicles in Sweden	SNG (+heat + O <sub>2</sub> )	Power grid	1.2 MW <sub>ch</sub> SNG	Yes (week) Yes (gas grid)	Sweden, 2012
5 Synthetic methanol production from electricity and various carbon sources in Denmark	Methanol (+heat)	Power grid, (+ biomass + NG)	233 MW <sub>ch</sub> methanol	No Yes	Denmark, 2009
6 Back-up system for reliable power supply to remote communities powered by renewables and diesel imports	Reliable power supply	Intermittent renewable	< 250 kW <sub>e</sub> output	Yes (days to weeks) No	Various, 2004 - 2012
7 Autonomous system for photovoltaic-powered telecom tower in remote location	Back up power	PV	5 kW <sub>e</sub> output	Yes (days to weeks) No	India, 2011-2015 projection
8 Bulk electricity storage for inter-day price arbitrage	Price arbitrage on power markets	Power grid	50 MW <sub>e</sub> output	Yes (days) No	US, 2009 and future cost projections
9 Long term, grid-scale electricity storage in Germany, the <i>Energiewende</i>	Grid-scale power services	Power grid	>100 MW >100 GWh	Yes (week to months) No	Germany, future scenario

# Case study No. 1: Optimization of hydrogen production costs from price arbitrage on both spot and balancing electricity market for grid-connected electrolyzer

## Assumptions

**Project type:** power-to-hydrogen project

**Market:** day-ahead spot; balancing market

**Electricity price:** EPEX Spot for France, EEX for Germany and OMEL for Spain, data from January 2010 to September 2012

**Electricity source:** grid-connected

**Electrolyzer size:** 125 MW alkaline electrolyzer

**Electrolyzer parameters:** minimum load 25% of installed power; maximum load 100% of installed power; ramping 10 mins from minimum to maximum  
load; efficiency: 77%<sub>HHV</sub>; investment cost €1,200 /kW<sub>e</sub>; annual operating cost (except electricity consumption, fixed O&M) 2% of investment; operating life of the electrolyzer 15 years; operating life of the plant 30 years; plant construction duration one year.

**Discount rate:** 8%

**Currency:** euro

## Scenarios:

*Continuous operation (Spot cont.):* operate the electrolyzer fully and continuously whatever the day-ahead spot price.

*Fluctuating operation for spot price arbitrage (Spot optim.):* fully operate the electrolyzer only when the day-ahead spot price is lower than a defined threshold price, otherwise, due to its technical constraints, the electrolyzer is not completely shut down but its production is reduced to its minimum load. The benefits of this strategy are explained in detail in (section 2.2)

*Continuous operation with a positioning on the balancing market [BM] (Spot cont. & BM):* The electrolyzer works continuously unless participating in the balancing market (by reducing consumption) is more profitable than selling hydrogen at a defined price.

*Fluctuating operation for spot price arbitrage with additional positioning on the balancing market (Spot optim. & BM):* The system is operating as in the previous fluctuating approach but when it was supposed to fully operate, if participating in the balancing market (by reducing consumption) is profitable the process is reduced to minimum load and when it was operating at minimum load, if participating in the balancing market (by increasing consumption) is profitable the process is increased to maximum load.

## Credits for the case study

Mansilla et al. (2013), "Economic competitiveness of off-peak hydrogen production today – A European comparison", Christine Mansilla, Jeremy Louyrette, Sandrine Albou, Cyril Bourasseau, Séverine Dautremont, Energy (2013);

Mansilla et al. (2012), "Electric system management through hydrogen production – A market driven approach in the french context", Christine Mansilla, Jeremy Louyrette, Sandrine Albou, Cyril Bourasseau, Nathalie Collignon, Séverine Dautremont, Julien Martin, Françoise Thais, International Journal of Hydrogen Energy, vol. 37, pp. 10986-10991

# Intermittent energy penetration does influence the electricity market, but its effect is highly complex and difficult to define – no clear correlations with price variability have been observed in regions with penetration below 20%

This case study illustrates the gain of different market-driven price arbitrage strategies on the levelized cost of hydrogen [LCOH] produced from a grid-connected electrolyzer (figure 211). The flexibility of electrolysis allows load modification in response to electricity prices, or when required by the electricity system regulator for energy balancing (see Box 9: electricity market). This case study does not take into consideration the application in which the hydrogen will be valorized.

The first part of the study is based on electricity spot-market prices in three countries – France, Germany and Spain – which have very different penetration rates for intermittent renewables (figure 212). France has the lowest penetration rate, with 2.6% of its electricity coming from solar and wind in 2011, compared with 11.2% in Germany and 17.7% in Spain. Interestingly, no correlation was found between the volatility of electricity prices on these spot markets and the penetration of intermittent renewables:

- In 2012, France had the largest price variability, which is linked to the spell of cold weather in February 2012. Spain has, on average, lower price variability than Germany, despite being a poorly interconnected peninsula with higher intermittent penetration (figure 213).
- Hourly price variability in France and Germany has not revealed any clear trends in the past three years. Although the intermittent-power penetration rate increased between 2010 and 2011, hourly price variability was greater in 2010.

The market price of electricity is, in fact, affected by many factors: power plant availability, weather, the economic situation, market regulation, interconnection with other networks, and, of course, variable power penetration. The latter does influence electricity spot prices, but de-correlating its specific effect is difficult.

These conclusions are highly system-specific and should not be extrapolated to other power systems. In particular, the lack of correlation observed for an intermittent penetration rate of 0-20% might not hold true for higher penetration rates.

Figure 211: Project layout

 Scope of the project's economics

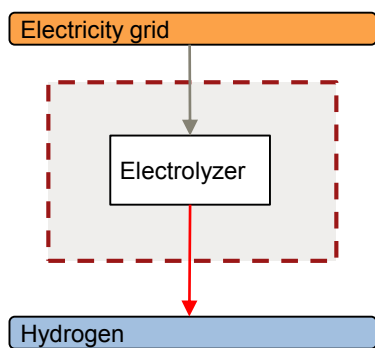

Figure 212: Intermittent power penetration rate % of electricity produced annually by wind and solar

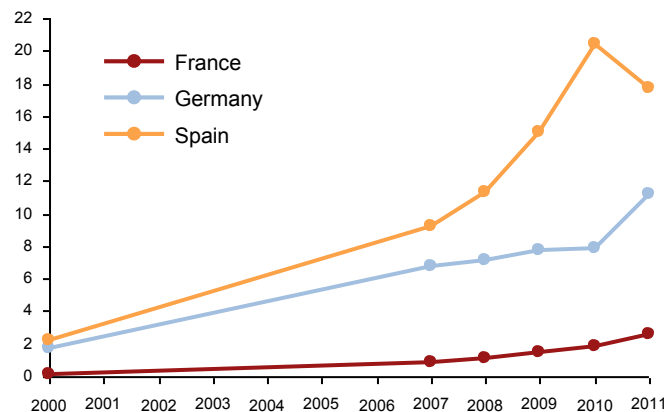
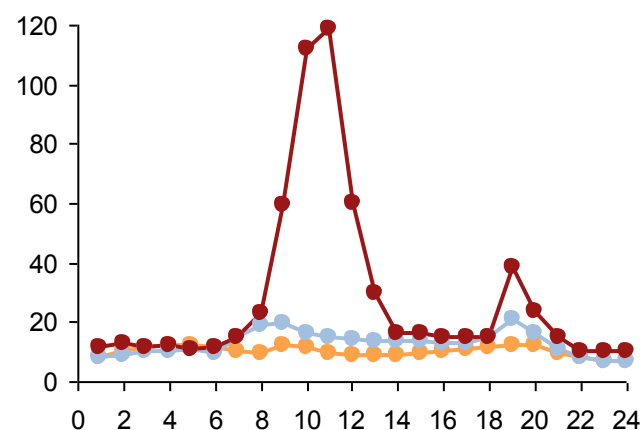

Figure 213: Hourly variability in 2012 €/MWh



# Spot market arbitrage alone is not sufficient to make a business case for hydrogen

The first part of the business case relates to the spot-market price of the electricity used to feed electrolyzer operations in France, Germany and Spain. Two different approaches are considered: continuous (*Spot cont.*) and fluctuating (*Spot optim.*).

The study is based on spot market prices from 2010 to 2012. Highest, lowest and mean values give a good idea of the price volatility of the three countries for each year (figure 214). While mean values were quite stable for all three markets, France showed a spectacular price increase in 2012 and Spain had numerous “zero” prices in 2010, reducing its mean value.

Figure 215 shows the levelized cost of hydrogen [LCOH] for a continuous operation and the gain obtained with spot-price optimization. **All the prices are in the €75-90 /MWh range** (except for Spain in 2010) and load factors vary between 70 and 95%. Large spreads on the French spot market clearly enhanced the gains of an optimized operation, while a low mean value in Spain in 2010 significantly reduced the LCOH for both scenarios. However, it seems that, **whatever the market conditions, the value gained through the optimized approach is very small** (less than 3% gain in LCOH).

The cost of hydrogen production from steam methane reforming is estimated at around €38 /MWh in Europe – around half of the cost of production from electrolysis. Electrolytic hydrogen is penalized by the large investment cost that needs to be amortized. In order to estimate sensitivity to the investment cost, **the same study was carried out with an investment half the cost previously considered. Results show a global LCOH reduced to €64-75 /MWh** and also an improved gain from fluctuating operation – 4.6% in France in 2012. Indeed, the lower capital costs allow the system’s load factor to be reduced to 60-70% in the *spot optim.* scenario.

**Overall, market-driven operation does not seem to result in a high valorization of fluctuating hydrogen production**, when only the spot-market price is considered. Reduction in electrolyzer investment costs will not make enough difference to compete with steam methane reforming. **The key might be to valorize the electrolyzer, a flexible asset, more effectively by also providing ancillary services to the grid**, like balancing mechanisms (see next slide).

Figure 214: Spot market price range and mean value €/MWh<sub>e</sub>

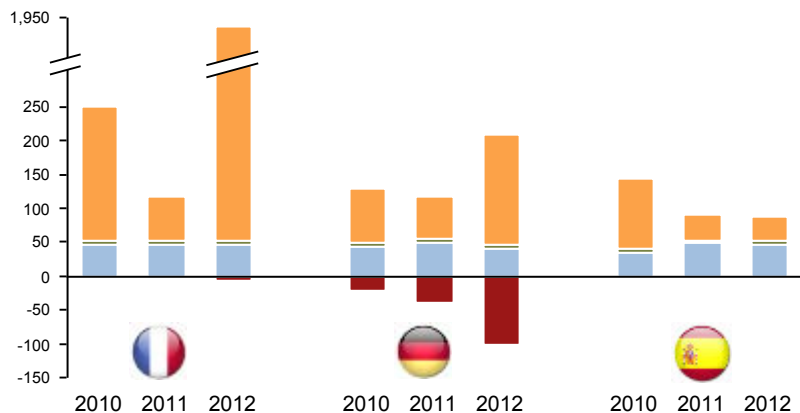
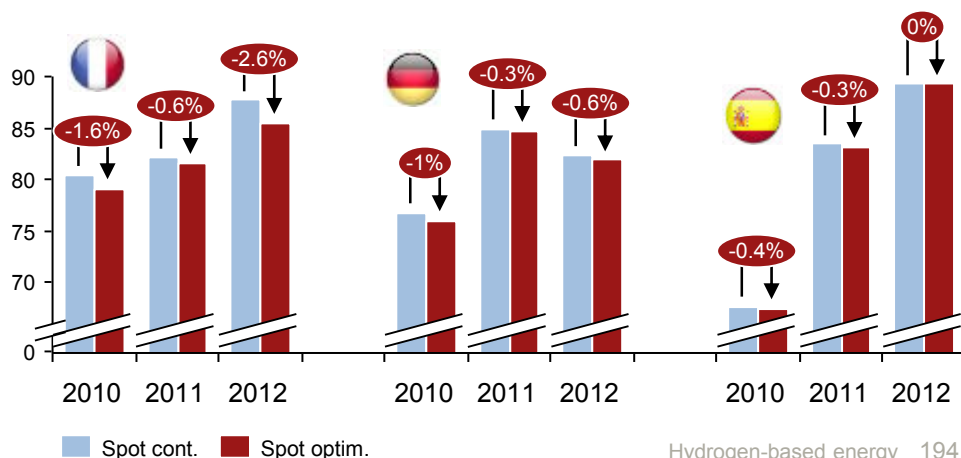

Figure 215: LCOH for continuous and fluctuating operations €/MWh<sub>ch</sub>



Source: Case study based on Mansilla et al. (2013).

# When participation in the balancing market is possible, the levelized cost of hydrogen can be reduced by almost 9% compared with continuous operation

The second part of the business case relates to the impact that participating in the balancing market<sup>1</sup> could have on the cost of hydrogen production. It focuses solely on the French market. Results are shown in figure 216:

- If the price arbitrage on the spot market could reduce the levelized cost of hydrogen [LCOH] by 2% (spot optim.), additional arbitrage on the balancing market (spot optim. & BM) would decrease the LCOH by a further 5%.
- Interestingly, when participating in the balancing market, optimizing the spot market becomes redundant, and even carries a slight penalty: the spot cont. & BM strategy brings a 9% gain in LCOH compared with continuous operation, against 7% for the spot optim. & BM when they both have the same load factor (64%). This occurs because, when operation is driven by the spot-market price and prices are high, operation is at minimum load and cannot be reduced further. But it might have been more profitable to offer a load reduction to the balancing market.

Overall, the best strategy is to operate the system continuously, while participating in the balancing market when profitable. Yet this requires highly flexible electrolyzers, able to ramp up or down in a matter of minutes, which should suit proton exchange membrane more than alkaline electrolyzers. A sensitivity for the best scenario (figure 217) shows, not surprisingly, that efficiency and investment costs have a great impact on LCOH. Even with the best utilization strategy and a 25% reduction in capital costs, electrolysis would cost more than steam methane reforming [SMR]. Selling oxygen or heat, which are by-products from the electrolyzer could help. But the gap might only be closed by accounting for the relative carbon footprint of SMR versus the electrolyzer.

Two comments should be made about this business case: first, if the capacity of grid-connected electrolyzers were to increase significantly, the impact on electricity prices from additional consumption and the cannibalization of price-arbitrage opportunities by those same electrolyzers need to be taken into account. Second, the scenarios, including BM participation, considered the French market only, where price volatility is among the most extreme because of non-dispatchable baseload nuclear power plants; gains would have probably been lower for Spain and Germany.

**Figure 216: LCOH and load factor with balancing market strategies**  
€/MWh<sub>ch</sub>

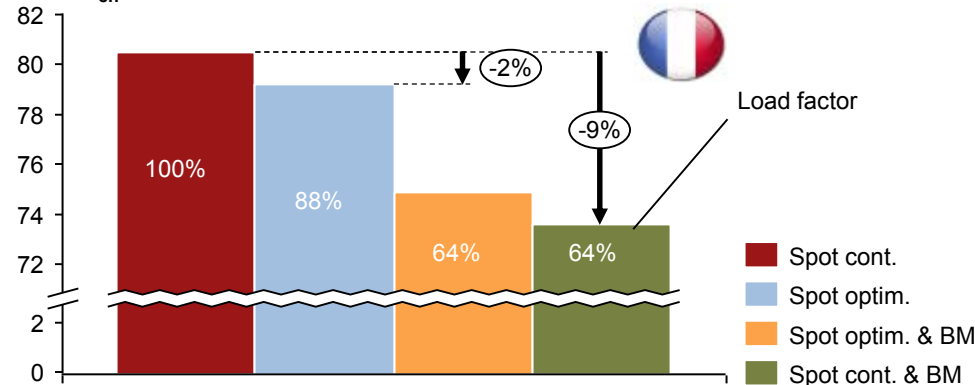

**Figure 217: Sensitivity analysis results, for the scenario spot cont. & BM**

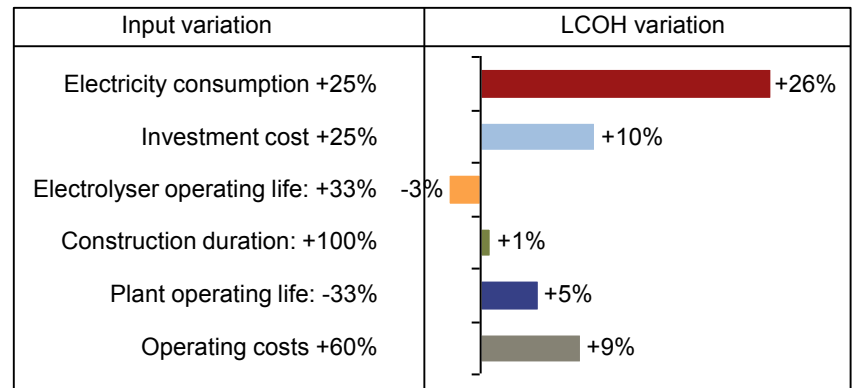

1. Flexible generators able to increase or decrease their output at short notice and/or end-users with the capacity to vary their consumption quickly can correct unforeseen short-term imbalances in real time. These adjustments create a balancing market [BM], in which the grid-connected electrolyzer can participate, extending its options for price arbitrage beyond the spot market.; Source: Mansilla et al. (2012).

# Box 9: Electricity markets

Figure 218: Spot market and balancing market flowchart

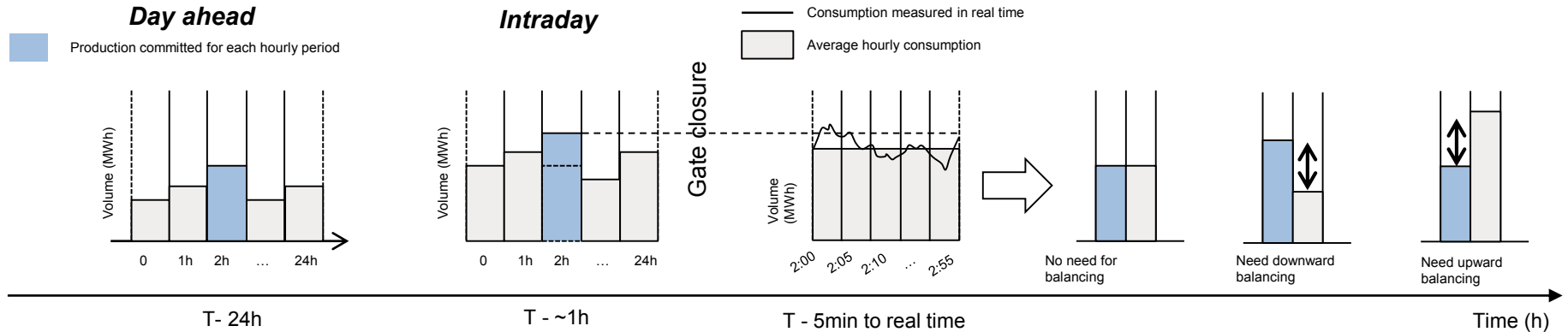
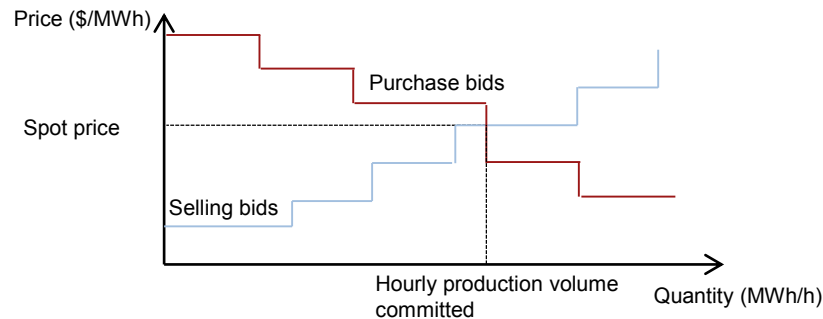

Figure 219: Price/volume curve for each hourly period



1. The spot market sets the price of electricity in advance for a one-hour period. The matching of electricity supply offers (sell bids from electricity producers) with electricity demand offers (purchase bids) creates an hourly spot price and an hourly production-commitment volume. The spot-market price is the same for all players and corresponds to the marginal price of the last unit called. The spot market is generally split between:
  - The day-ahead market, which refers to all the trading that occurs 24h before gate closure; and
  - The intraday market, which readjusts the day-ahead price to the most recent forecasts, generally 1-3 hours in advance.

2. After gate closure of the spot market, producers are committed to provide a fixed amount of power for one hour. However, unpredicted variations of supply and demand during this period must be rectified in real time. The second-to-minute mismatch is automatically absorbed by the inertia of rotary power generators (see Section 1.2).
3. However, operating reserves are limited. Sustained imbalances (summarized by the average hourly imbalance) need to be compensated for manually by the transmission system operator [TSO]. For that purpose, the TSO calls for tenders of balancing offers:
  - Upward balancing offers: increase in production, decrease in consumption, imports;
  - Downward balancing offers: decrease in production, increase in consumption, exports.
4. The participants agree in advance to be available for balancing services for a sub-hourly period during which they bid. The TSO calls on them according to the merit order of bidding prices, i.e. selecting additional capacity in ascending order of price, starting with the cheapest. Two types of pricing methods exist:
  - Marginal pricing: all participants are compensated for their services at the marginal bid price, which defines the upward or downward imbalance market price in \$/MWh<sub>0</sub>; and
  - Pay-as-bid: all participants receive the price of their bids if they are accepted by the TSO.
5. The TSO pays for upward balancing offers, but receives payment for downward offers.

# Case study No. 2: Hydrogen-enriched natural gas from grid-connected electrolyzer with various wind-penetration scenarios in Denmark

## Assumptions

<b>Project type:</b>	power-to-hydrogen plant with injection into the gas grid
<b>Location, year:</b>	western Denmark, future scenario
<b>Electricity source:</b>	grid-connected, spot-market price estimations for various wind-penetration scenarios
<b>Hydrogen sales:</b> is	feed-in tariff [FIT] increases linearly with the wind-energy content of the hydrogen produced: for 100% wind-hydrogen, FIT equivalent to biomethane FIT applied in Denmark (€154 /MWh <sub>ch</sub> , as of May 2013). For 0% wind-hydrogen, no additional incentives are given and FIT equals the natural gas spot-market price in Denmark (€34 /MWh <sub>ch</sub> , as of May 2013)..
<b>Oxygen sales:</b>	€18 /tO <sub>2</sub> for merchant distribution
<b>Project size:</b>	5 MW <sub>ch</sub> alkaline electrolyzers
<b>Transport/storage:</b> electrolytic need for	no. The plant is connected to a distribution grid with a minimal flow rate of 90 MW <sub>ch</sub> , large enough to absorb all the hydrogen produced at anytime during the year, while complying with the blending limit of 20 vol.%, and bypassing the dedicated hydrogen storage.
<b>Financial assumptions:</b>	
Energy efficiency:	78% <sub>H<sub>HHV</sub></sub>
Capital cost:	€840 /kW <sub>ch</sub> H <sub>2</sub> (includes €190 /kW <sub>ch</sub> for connecting H <sub>2</sub> to the gas grid)
Operational costs:	~20% of capital costs each year
Discount rate:	10%

## Credits for the case study

The case study is based Jørgensen et al. (2008), “*Production price of hydrogen from grid connected electrolysis in a power market with high wind penetration*”, Claus Jørgensen, Stephanie Ropenus for electricity spot-market assumptions, and on US DoE H2A models for system-cost parameters.

# High penetration of intermittent renewables in the electricity grid results in increased spot-price volatility

This case study illustrates the economic feasibility of enriching the natural gas grid with hydrogen produced from grid-connected electrolyzers. It investigates various wind-penetration scenarios in Denmark: 20%, 50%, 75% and 100%. An electricity spot-prices duration-curve has been estimated for each scenario (figure 221) by Jørgensen et al. (2008). The estimates are derived from the observation that, between 2000 and 2008, the volatility of spot prices has been fairly well correlated (positively) with wind penetration in western Denmark. In this case study, the correlation has been extrapolated for larger wind penetrations (50%, 75% and 100%), assuming that the annual average spot price remains unchanged at €50 /MWh<sub>e</sub>. Extrapolation shows that if the market structure does not adapt to cope with increased intermittent production, there will be more periods of relatively high and low electricity prices, improving opportunities for price arbitrage.

It is important to note that these electricity prices are the building blocks of the following study, but should not be taken as forecasts of future prices. Indeed, as shown in the previous case study, the specific effect of intermittent renewable penetration is very complex, and there is no evidence linking a high degree of renewable power penetration in the electricity system with enhanced price volatility – in the cases of the French, German and Spanish spot markets.

Hydrogen is sold to the gas-distribution system operator at a contracted feed-in tariff [FIT] proportional to the green-energy content of the electricity used to produce hydrogen. However, in practice, it is not possible to determine the origin of the electricity bought when it is collected from the grid. Nevertheless, as shown in the Box 10 regarding renewable energy certificates, it is possible to account for the green content of the electricity bought for electrolyzers fairly in the price.

Figure 220: Project layout

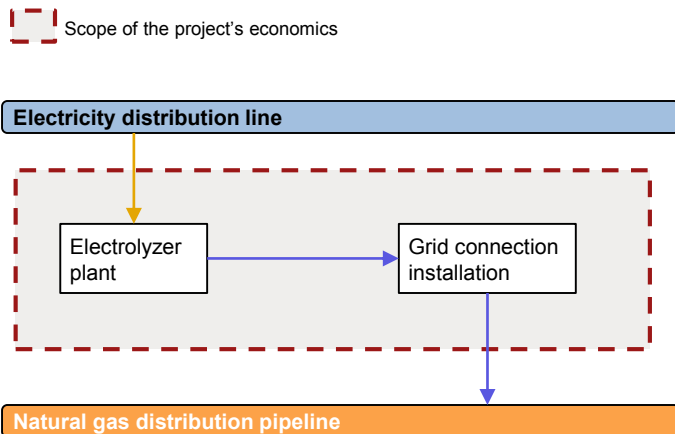
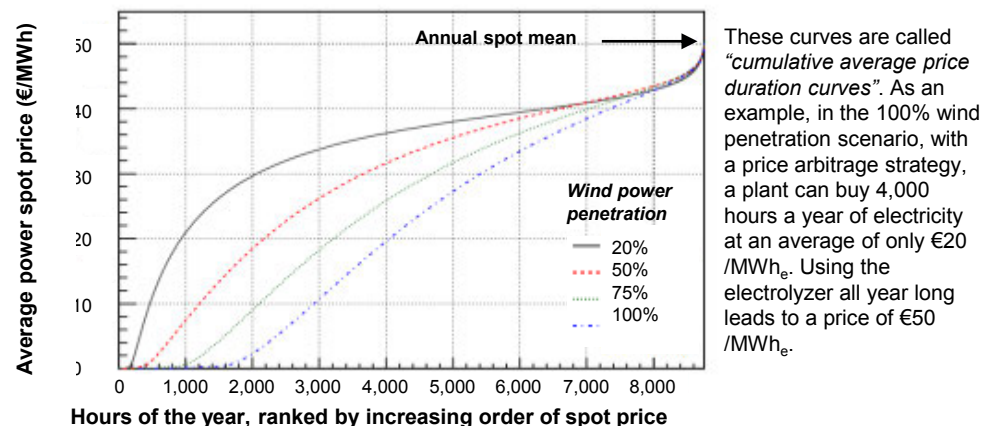

Figure 221: Estimated lowest obtainable average spot price for purchasing power during a given number of hours in Denmark



# Electricity-price variations can lead to reductions in electrolytic hydrogen production costs, but this may result in a fall in renewable energy's share of production

Electrolytic hydrogen production has the advantage of being flexible, allowing the electrolyzer to operate according to the spot market and so use only the most favorable electricity prices available. The cost of H<sub>2</sub> production + injection has been calculated<sup>1</sup> using assumptions shown in the previous slide (figure 221). When used continuously during the year, hydrogen costs €146 /MWh<sub>ch</sub> to produce, 75% of which is electricity costs, and 25% of which is electrolyzer costs. Otherwise, **there is an electrolyzer utilization rate that minimizes hydrogen production costs for each wind-penetration scenario:**

- **If wind penetration is less than 50%** and if the objective is to minimize H<sub>2</sub> production costs, **electrolyzers should be operated for 90% of the time**, only shutting down when prices peak. A saving of 9% on production costs is achievable compared with continuous operation.
- **It is only economically profitable for electrolyzers to operate part time if wind penetration is high.** In any case, it would not be profitable for them to operate solely using temporary excesses of electricity produced from renewable energy.

**Yet the more grid-connected electrolyzers are used during the year, the lower the renewable content of their electricity input.** Jørgensen et al. (2008) quantified the average alternative power used by electrolyzers for different wind-penetration scenarios (figure 223): optimizing H<sub>2</sub> costs in a 20% wind-penetration scenario results in only 22% of the hydrogen produced coming from wind energy.

**There is a trade-off between pure production costs and the renewable content of its hydrogen.** One might not necessarily favor minimizing production costs, since the selling price of hydrogen might depend on its renewable energy content (see next slide). However, grid-connected electrolyzers operating in peak-shaving mode would contribute to increased consumption of non-intermittent electricity, often carbon fuel-based.

**Figure 222: Levelized cost of hydrogen fed into the gas grid as a function of electrolyzer operating hours per year for different wind penetrations<sup>1</sup>**

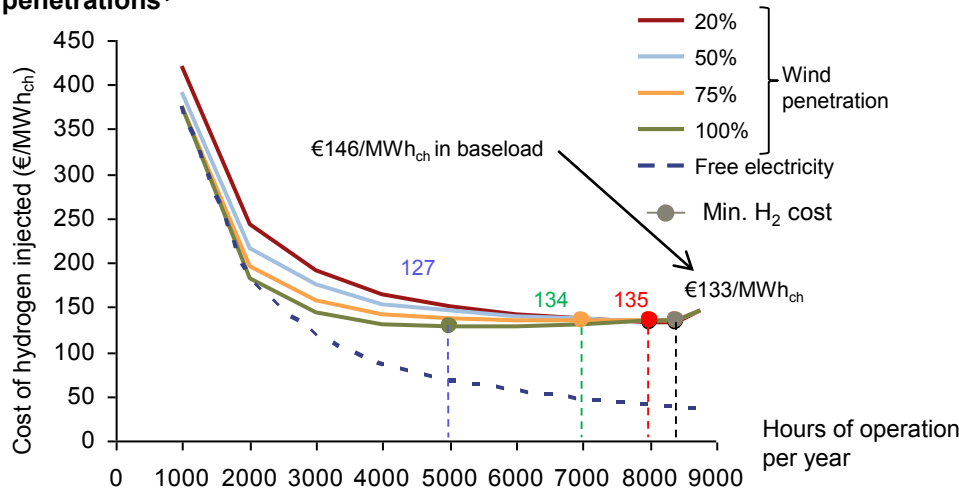

**Figure 223: Average contribution of non-wind power sources as a function of electrolyzer operating hours for four different wind-penetration scenarios<sup>2</sup>**

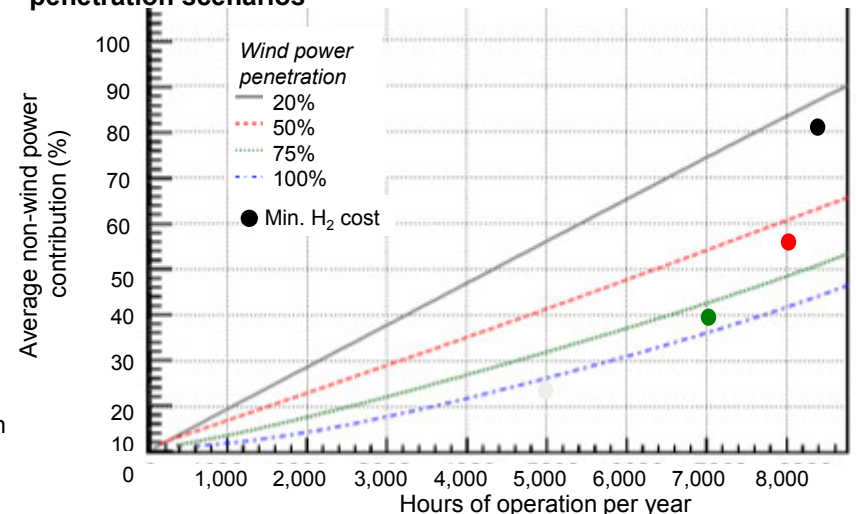

Source: 1A.T. Kearney Energy Transition Institute analysis, based on US DoE H2A production models with plant cost assumptions defined in the assumption slide and electricity prices defined in the previous slide. <sup>2</sup>Adapted from Jørgensen et al. (2008), by adding the Min. H<sub>2</sub> cost data point based on figure 220.

# A very large wind penetration is required to make electrolysis projects viable, even with green gas feed-in tariffs

**The profitability of an electrolysis project depends not only on hydrogen-production costs, but also on the quantity of hydrogen and the price at which it can be sold.** The selling price of hydrogen depends on the green-energy content of the electricity used to produce it. In this analysis, green-energy content is synonymous with wind-energy content, as Danish electricity is currently generated principally by wind and fossil-based energy. Therefore, feed-in tariffs [FIT] are assumed to increase linearly with wind-energy content.

The results of this business-case analysis are shown for each wind-penetration scenario (figure 224). **At the current wind-penetration rate, of 20%, the project owner loses money:** the optimal utilization strategy involves using the electrolyzers 54% of the year, but even operating under optimal conditions, the owner will still lose €52 /MWh<sub>ch</sub> of H<sub>2</sub> produced. In addition, in reference to figure 223 in the previous slide, 50% of the electricity used for the electrolyzer is non-renewable. **The project's break-even point would be attained if the FIT for green gas reached €245 /MWh<sub>ch</sub>, which is 7.6 times the spot price of natural gas – i.e. a price that, at present, would be unacceptable to consumers.** In comparison, FITs for the newest offshore wind farm in Denmark amount to 3.9 times the spot price of electricity<sup>1</sup>. **Only the 100% wind-penetration scenario offers an opportunity for positive present value with biomethane-like FITs.**

This case study gives a rather **pessimistic outlook for current investors.** Various factors should positively influence the outcome of this business case:

1. Power-to-gas projects provide indirect benefits to electricity transmission system operators that are not reflected in the biomethane FIT or the spot-market price. For instance, participating in the balancing market could reduce the cost of electricity (see previous case study and Box 9: electricity markets);
2. The 2012 average spot electricity price in Denmark was 38% lower than the one used in this study;
3. By 2020, the cost of electrolyzers is expected to have decreased and that of natural gas to have increased; and
4. Feed-in tariffs could be offered regardless of the origin of electricity in countries with low- carbon grid electricity, such as Norway, Sweden or France. However, it is important to note that there is currently neither clear legislation nor FIT in place in Denmark or elsewhere for hydrogen feed-in.

**Figure 224: Levelized cost of injected hydrogen and feed-in tariffs**

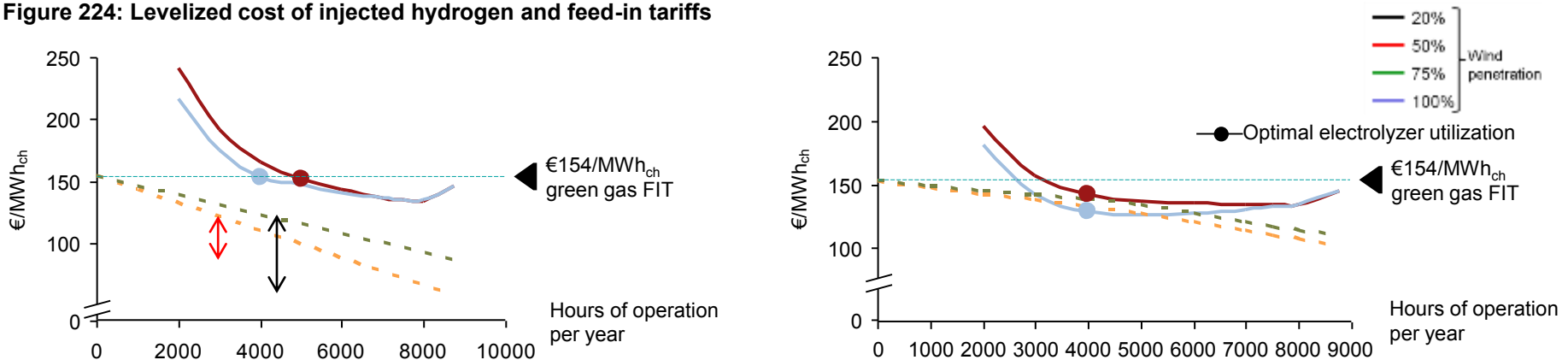

1. According to the Danish Energy Agency, the latest Anholt offshore project will receive a 1.051 DKK/kWhe of FIT, while the NordPool spot in Denmark averaged 0.24 DKK/kWhe in 2012.

Source: A.T. Kearney Energy Transition Institute analysis, based on Jørgensen et al. (2008) for the electricity prices and share of wind power used.

## Box 10: Renewable energy certificates

Figure 225: Schematic of renewable energy certificates

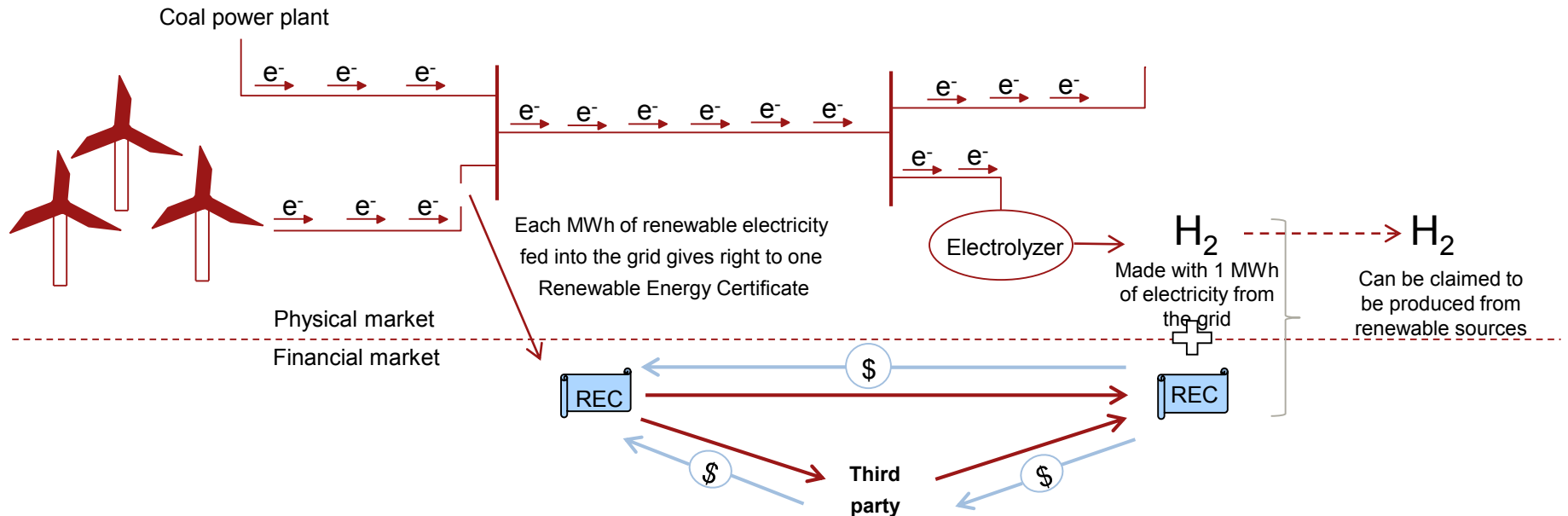

- After they have been fed into the grid, electromagnetic fields from different sources are mixed, making it impossible to determine an electromagnetic field's origins. This also makes it impossible to guarantee to customers that they will receive only renewable electricity. To trace the electricity produced from renewable sources, certificates have been introduced in a few countries (US, Europe, Australia, India etc.)
- A renewable energy certificate [REC], as it is known in the US, is a tradable energy commodity representing proof that 1 MWh of electricity has been generated from a renewable source.
- In the US, certificates can be sold on two kind of markets: a compliance market, in which electricity companies buy certificates because they are required to supply a certain percentage of their electricity from renewable generators, and a voluntary market in which purchasers choose to buy certificates.
- Certificates benefit both renewable generators and purchasers: for a generator, the revenue gained from certificates can be offset against expenses, increasing competitiveness with conventional generators. Meanwhile, a purchaser can claim to have consumed renewable electricity, allowing an electrolyzer owner to sell "green" hydrogen, provided that this owner buys enough RECs to cover the MWh of power used for the production of that hydrogen, even if that power came from fossil fuels.

# Case study No. 3: Liquid hydrogen production and delivery to refueling stations from a dedicated wind-power plant in the US

## Assumptions

<b>Project type:</b>	wind-to-liquid H <sub>2</sub> production and delivery
<b>Location, year:</b>	production in Albuquerque, NM and delivery in Los Angeles, CA
<b>Electricity source:</b>	dedicated wind farm and power grid priced at \$47 /MWh <sub>e</sub> . The grid electricity price for this project results from electricity purchased at a base price of \$60 /MWh <sub>e</sub> , \$80 for the summer peak and \$40 for the winter off-peak. The project owner considers the electricity produced from wind farms for electrolyzers and liquefiers to be “free”.
<b>Annual capacity factor of the wind farm:</b>	42%
<b>Oxygen sales:</b>	none
<b>Project size:</b>	255 MW <sub>e</sub> wind farm + 67 MW <sub>ch</sub> electrolyzers
<b>Transport:</b>	fleet of 32 trucks carrying \$800,000 worth of hydrogen each over a distance of 1,300km
<b>Storage:</b>	10.7 GWh <sub>ch</sub> liquid storage (6-days at nominal production rate)
<b>Financial assumptions:</b>	
	Total capital cost for project: \$10,300 /kW <sub>ch</sub> of H <sub>2</sub> delivered, of which \$1,500 /kW <sub>e</sub> for wind and \$800 /kW <sub>ch</sub> for the electrolyzer plant
	Electrolyzer efficiency: 79%
	Discount rate: 10%; Project lifetime 30 year
	Federal corporate and state taxes: 38% (net)
	The project owner receives \$15 for each MWh <sub>e</sub> of wind electricity sold to the grid in the form of tax credits over 10 years

## Credits for the case study

The case study is based on Argonne National Laboratory (2011), “*Liquid Hydrogen Production and Delivery from a Dedicated Wind Power Plant*”, Amgad Elgowainy, Marianne Mintz, Darlene Steward, Olga Sozinova, Daryl Brown, Monterey Gardiner

# Centralized hydrogen production can be located close to the best wind resources

The following business case encompasses the whole value chain, from wind farm to H<sub>2</sub> refueling stations (figure 226). The project is designed to continuously supply H<sub>2</sub> to 80,000 fuel-cell electric vehicles [FCEV] in 35 refueling stations in the Los Angeles basin, which is consistent with projected regional demand for the end of this decade. Each station is assumed to receive one liquid truck shipment of 190 MWh<sub>ch</sub> every four days. **Hydrogen is transported, stored and delivered in liquid state.** Cryo-evaporators then passively transform liquid H<sub>2</sub> into 430-bar gas, which can be loaded, with minimal losses, into 350-bar vehicle tanks, ready for use. Both the electrolyzers and the wind farm are connected to the power grid by a transmission line, allowing the electrolyzer to operate continuously in the absence of wind. The wind farm is designed to achieve renewable electricity neutrality with respect to the grid. The renewable electricity neutrality condition states that the sum of temporary excesses of electricity fed into the grid in a year should equal the electricity withdrawn to maintain the electrolyzer in continuous operation. It is interesting to note that the **electrolyzer plant rated capacity is only about a quarter of the wind farm's capacity** and consequently only costs 6% of the total project CAPEX (figure 227).

Figure 226: Project layout

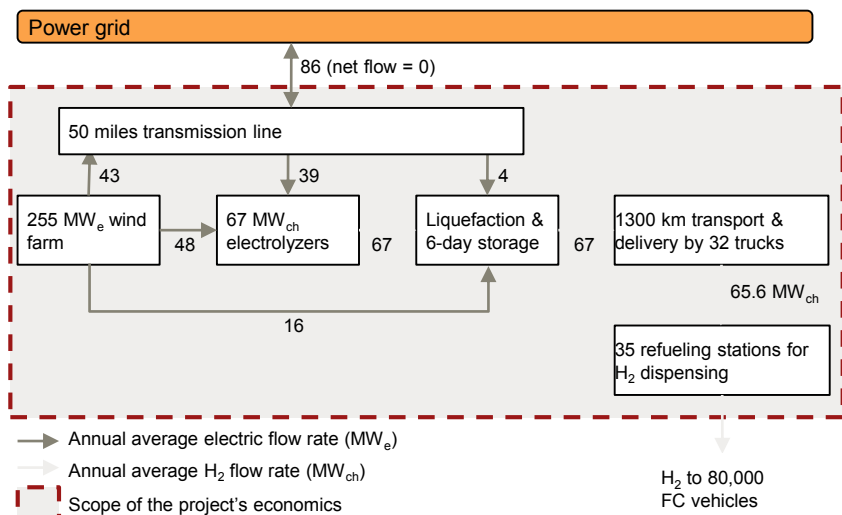
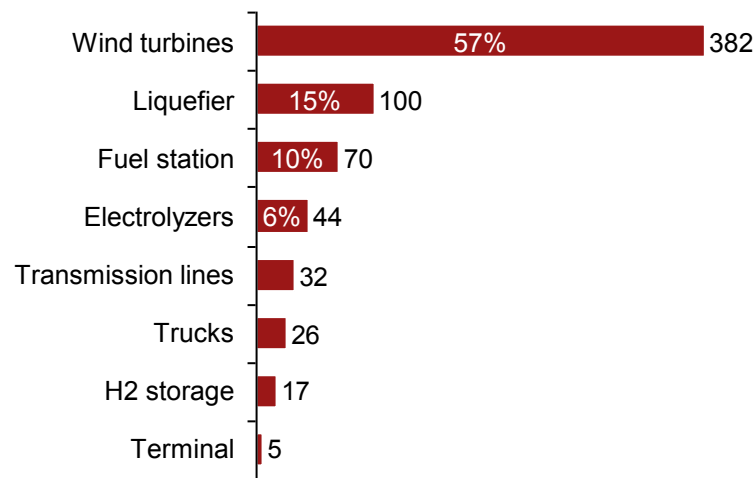

Figure 227: Capital costs breakdown (total = \$675 million) \$ million; and % of total



# Transporting hydrogen over long distances appears manageable, but the cost of the renewable electricity itself remains an issue

The calculated cost of hydrogen at the refueling station is \$297 /MWh<sub>ch</sub> if it is transported there, which is equal to \$2.9 /Lge (liter of gasoline equivalent) in chemical energy content. But the US DoE estimates that, in future, the price of hydrogen dispensed at the refueling station will need to drop below \$160 /MWh<sub>ch</sub> to stimulate demand for fuel-cell electric vehicles and make them competitive with other efficient vehicles, particularly hybrids. **As shown in figure 228, this business case is not yet economically viable. However:**

- **The capital costs** of wind turbines, liquefiers and electrolyzers account for 75% of the levelized cost of the delivered hydrogen, but this share is likely to decrease in future as capital costs fall (figure 228).
- **Environmental benefits** have not been taken into account in this case study. Figure 229 shows that renewable hydrogen used for transport displaces oil consumption, thereby reducing GHG emissions by 96% compared with conventional gasoline vehicles in the US, and avoiding local pollution (aerosols, NO<sub>x</sub> etc.). Figure 229 shows that using grid electricity has negative environmental impacts. Hence, the author of the study assumed that the project must achieve renewable electricity neutrality.

To conclude, renewably produced hydrogen presents obvious advantages for the future of mobility, but its production cost remains an issue. Unless the cost of wind turbines drops and/or that of fossil fuel rises, natural gas reforming will remain cheaper than wind-powered electrolysis in the US. **Large, centralized hydrogen production destined for long-distance transport by truck appears to be a feasible option. Rail deliveries have also achieved comparable costs** and permit the exploitation of remote renewable resources. Finally, **the alternative project layout, consisting of a grid-isolated wind-to-H<sub>2</sub> system, was found to be significantly more expensive:** without the ability to purchase electricity when wind supply is low, the electrolyzer would have a utilization rate of only 42%, meaning that it would need to be oversized and several months of geological hydrogen storage would be required to maintain constant delivery.

**Figure 228: Breakdown of the levelized cost of delivered hydrogen**

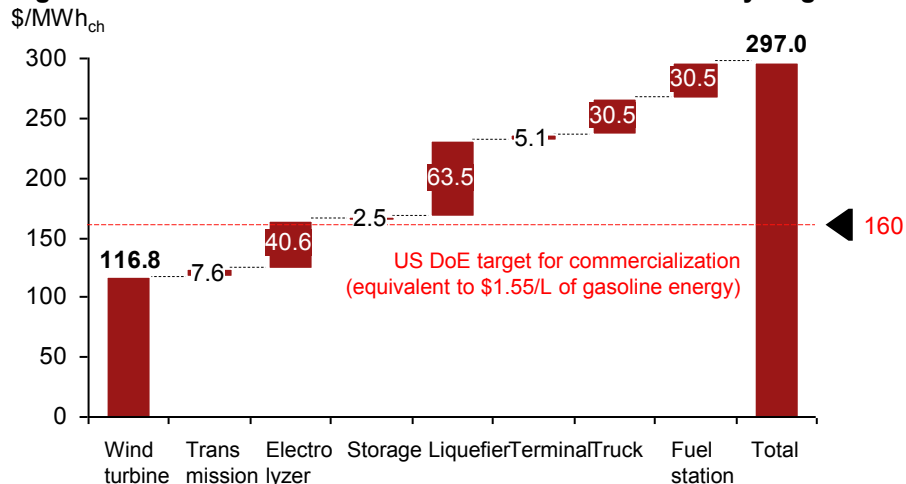

**Figure 229: Fuel-cycle greenhouse gas emissions**

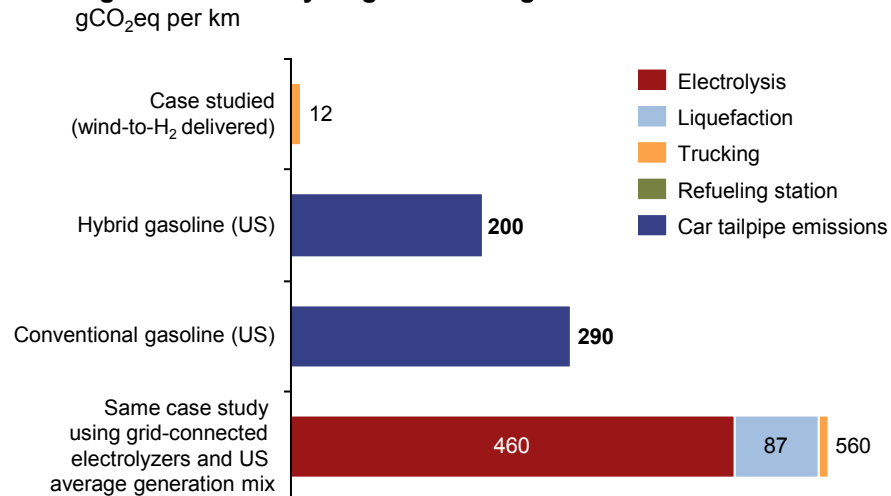

# Case study No. 4: Production of synthetic natural gas for compressed natural gas vehicles in Sweden

## Assumptions

**Project type:** grid-connected electrolyzer in conjunction with methanation reactor for synthetic natural gas [SNG] production

**Location/year:** Sweden, 2012

**Revenue stream:**

Synthetic natural gas: €133 /MWh<sub>ch</sub> (compressed natural gas [CNG] vehicle refueling stations)

Heat from methanation and electrolysis recycled for district heating: €31 /MWh<sub>th</sub>

Oxygen: €55 /tO<sub>2</sub>

**Electricity cost:** €54 /MWh<sub>e</sub>

Spot market: €47 /MWh<sub>e</sub>, based on the average market price for forward contracts for the 2012-16 period

Additional €7 /MWh<sub>e</sub> for transmission and distribution costs

Exempted from electricity tax of €31 /MWh<sub>e</sub> under Swedish law

**Electrolyzer:** 1.6 MW<sub>ch</sub> alkaline; 63% efficiency

**Methanation reactor:** 1.2 MW<sub>ch</sub> Sabatier thermochemical catalysis

**CO<sub>2</sub> source:** delivered for free from unidentified source.

**Transport:** no transport infrastructure owned by the project owner

**Storage:** 1,600 m<sup>3</sup> tanks of CH<sub>4</sub>, same for O<sub>2</sub>

**Utilization rate:** 8,000 hours/year

**Financial assumptions:**

Total uninstalled capital cost: €1.197 million (electrolyzer 53%; storage tanks: 25%, Sabatier reactor 14%; district heating connection 10%)

Installation costs: €622,000 (electrolyzer installed cost: €620 /kW<sub>ch</sub>)

Fixed O&M: 5% of the investment

Variable operating cost: €22 /MWh<sub>ch</sub> for SNG distribution; €3.3 /m<sup>3</sup> for water

Plant lifetime: 15 years with discount rate of 10%

## Credits for the case study

The case study is based on Mohseni et al. (2012), *“The competitiveness of synthetic natural gas as a propellant in the Swedish fuel market”*, Farzad Mohseni, Martin Göring, Per Alvfors, Royal Institute of Technology.

# Sweden has an electricity grid with very low CO<sub>2</sub> intensity and imposes high fossil-fuel taxes, creating an attractive price spread between natural gas and electricity

The following case study examines the economic feasibility of connecting a 2.6 MW<sub>e</sub> power-to-methane plant to the Swedish electric grid, and selling the synthetic natural gas produced exclusively to refueling stations (figure 230).

The plant operates 8,000 hours a year using grid electricity, which is virtually CO<sub>2</sub>-free in Sweden (5% of the European average CO<sub>2</sub>/kWh<sub>e</sub>, thanks mainly to hydro and nuclear production, which account for 44% and 41% of power generation, respectively<sup>1</sup>). Therefore, **the SNG produced is carbon neutral and exempt from petroleum and CO<sub>2</sub> taxes**. It is assumed that the CO<sub>2</sub> for methanation is delivered without cost from an unidentified source – a nearby biomethane feed-in plant with built-in CO<sub>2</sub> separation is a likely candidate. The power-to-SNG energy efficiency is only 50% (conservative estimate).

### Various products are sold:

- **SNG:** The decentralized, small-scale plant is built near a gas-distribution grid. The plant pays an estimated €22 /MWh<sub>ch</sub> distribution fee to the gas-grid operator for injecting its SNG into the grid. It signs a gas purchasing agreement with one or several refueling stations at €133 /MWh<sub>ch</sub> for the methane delivered. For the refueling station, this buying price of SNG (equivalent to €1.3 /Lge) is similar to the price paid before VAT in 2012, due to the high petroleum taxes on fossil-based fuels but not on carbon-free SNG. In future, fossil-fuel pump prices are expected to increase, encouraging refueling stations to buy SNG at the contracted price from this plant. The market size for gas vehicles reached 17 TWh<sub>ch</sub> in 2012 (compared with 0.15 TWh<sub>ch</sub> in the previous decade) and accounts for 0.9% of total energy demand for road transport in Sweden. This share is certain to increase because of decarbonization policies encouraging biogas production for compressed natural gas vehicles.
- **Heat** is sold to a nearby district-heating-network operator at the average contracted price in Sweden. This requires the project to be built near to an existing grid.
- **High-purity oxygen** is stored and sold to merchant buyers for various potential applications.

Figure 230: Project layout

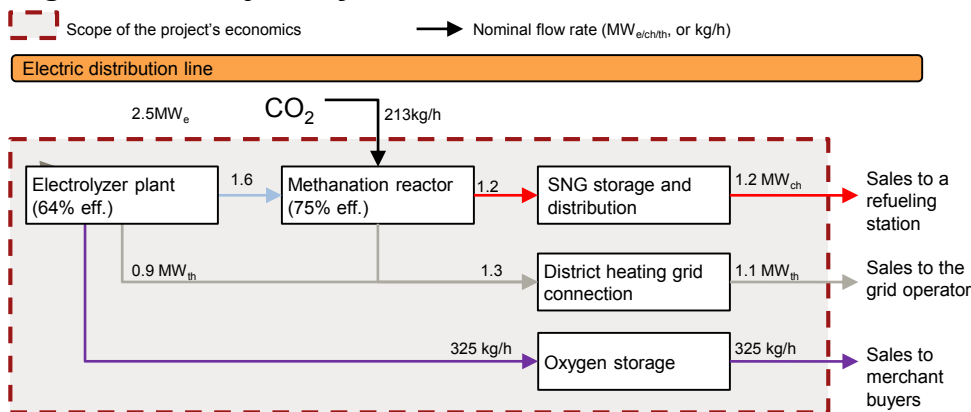
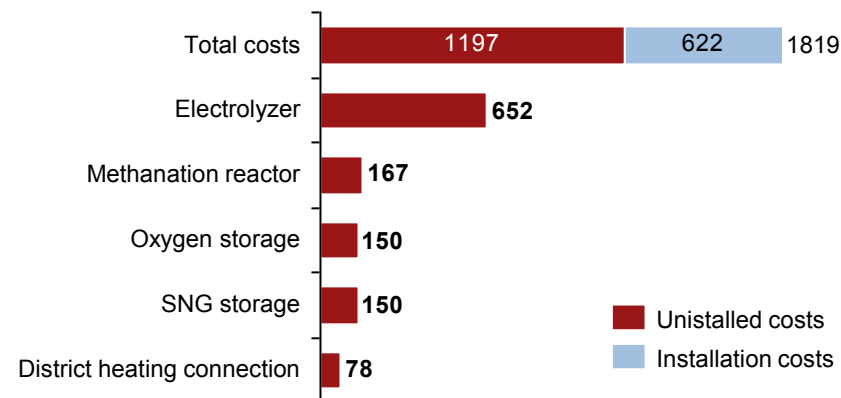

Figure 231: Capital cost breakdown in k€



Note: According to 2011 IEA data, wind and biofuels (including waste) account for 4% and 9% of power generated. Source: Mohseni et al. (2012).

# In Sweden, power-to-methane could be profitable for those who can bear the associated risks

In the base-case scenario defined in the assumption slide, the project brings a profit margin before tax of 5% (figure 232). The plant's profitability is mainly derived from the price spread between electricity bought and SNG sold. The sensitivity analysis relative to the base case reveals the following break-even conditions, which bring the net present value [NPV] to zero:

- **Discount rate break-even** (internal rate of return [IRR]): 16% before tax. Considering the risks associated with such first-of-a-kind projects, a high IRR is needed to attract investors. The main risks are: (1) technological (power-to-methane is at the demonstration stage); (2) legal (tax regime); (3) contractual (finding partners for CO<sub>2</sub> sourcing, SNG, oxygen and heat sales); (4) external (price spread between electricity and gas prices).
- **SNG sales break-even**: €124 /MWh<sub>ch</sub>, or €1.2/Lge<sup>2</sup>. This selling price remains compatible with sustained demand from an expanding fleet of CNG vehicles. The SNG/electricity price spread ratio should be above 2.6 in cost per energy content for the project to be profitable.
- **Electricity cost break-even**: averaging €51 /MWh<sub>e</sub> on the spot market, for 8,000 operational hours. In comparison, the average contract price for the coming 5 years is €47 /MWh (figure 233).
- **Operating hours break-even**: 3,700 hours/y in 2011 (figure 233). Electricity costs can be optimized by operating mainly during off-peak hours. In that case, the average price of electricity used decreases with non-operating time. However, the levelized cost of heat also increases with non-operating time. Therefore, increasingly cheap electricity is required for the project to break even. In 2011, the project would have been uneconomic for less than 3,500 hours of operation.
- **Capital cost break-even**: +30% investment cost compared with base case. The project's economics are less sensitive to capital costs than operating costs (figure 232), allowing for flexible operation.

**Figure 232: Breakdown of annualized cost of ownership<sup>1</sup> in the base case** in % of the annualized incomes

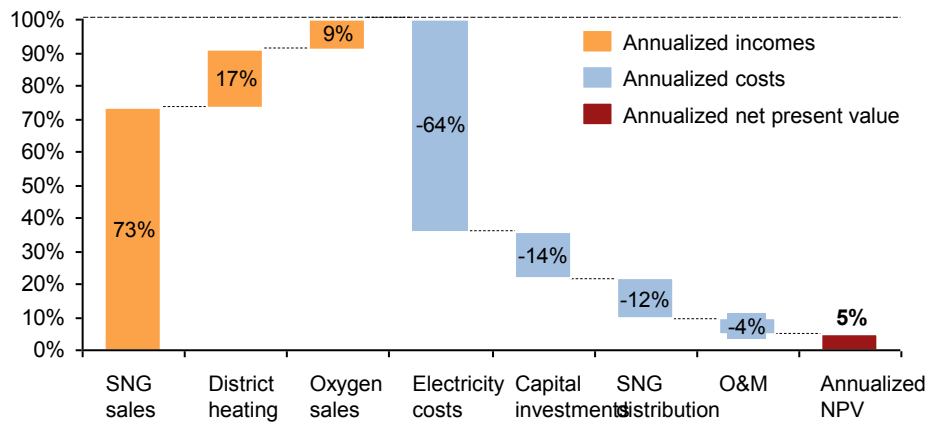

**Figure 233: Price duration curve of electricity price in 2011 in Sweden, and break-even electricity price as a function of operating hours**

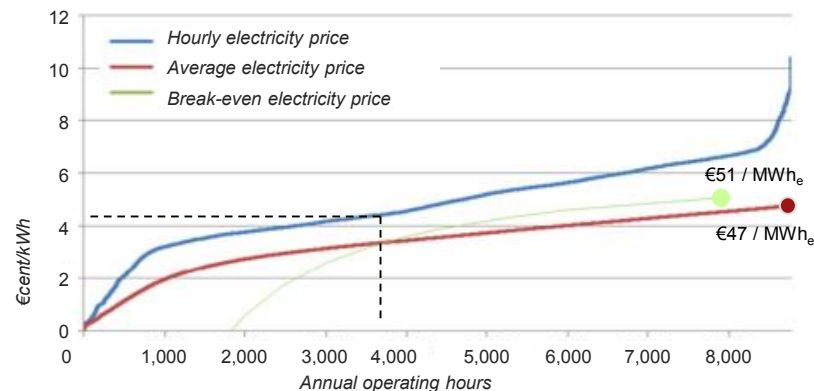

1. The Annualized NPV is also referred to as the equivalent annual cost; 2Lge: liter of gasoline equivalent. Source: Mohseni et al. (2012).

# Case study No. 5: synthetic methanol production from electricity and various carbon sources in Denmark



## Assumptions

**Project type:** large-scale power-to-methanol plant sells methanol to the wholesale market. Three different configurations, depending on the source of carbon.

**Location/year:** Denmark, 2009

**Plant size:** 233 MWh<sub>ch</sub> of nominal methanol output

**Utilization:** 8,000 hours/year

**Revenue stream:**

Methanol: sold on the commercial market. Base case: € 26.4 /MWh<sub>ch</sub> at the time of the study. €52 /MWh<sub>ch</sub> as of February 2013.

District heating: €25 /MWh<sub>th</sub>

**Feedstock costs:**

Electricity: grid-connected electrolyzer. Base-case electricity price €40 /MWh<sub>e</sub>

Biomass cost: €15 /MWh<sub>ch</sub>

Natural gas cost: €18 /MWh<sub>ch</sub>

CO<sub>2</sub> cost: €15 /tCO<sub>2</sub>

**Transport:** none

**Storage:** underground storage for hydrogen and oxygen

**Financial assumptions:**

Capital cost of uninstalled electrolyzer: €260 /kW<sub>ch</sub> (2 MW<sub>e</sub> alkaline stacks)

Underground storage cost: €96 /MWh<sub>ch</sub> of H<sub>2</sub> stored

Gasification capital cost: uninstalled: €450 /kW<sub>ch</sub>

Reforming capital cost: uninstalled: €140 /kW<sub>ch</sub>

Cost of uninstalled methanol synthesis & distillation facilities: €276 /kW<sub>ch</sub>

Annual fixed O&M: 4% of total investment

Capital cost per year: 15% of the total investment cost

## Credits for the case study

The case study is based on Clausen et al. (2010), “*Technoeconomic analysis of a methanol plant based on gasification of biomass and electrolysis of water*”, Lasse R. Clausen, Niels Houbak, Brian Elmegaard, Energy 35, pp. 2338-2347.

# The power-to-methanol chain may only be a minor part of electrolysis-assisted synthetic methanol production

The following case study compares three ways of synthesizing methanol from electrolytic hydrogen, depending on the origin of the carbon feedstock:

- 1 Pure CO<sub>2</sub> is streamed from an unspecified carbon-capture plant at €15 /tCO<sub>2</sub>. All energy input comes from the power grid, with an energy efficiency of 60% without district heating [DH], and 93% with DH.
- 2 Carbon is sourced from CO produced in biomass gasification. The system is termed an “electrolysis-assisted biomass-to-methanol plant”, as, in its optimal configuration, electricity is no longer the primary source of energy (40%). Energy efficiency is increased to 68.5% compared with method 1 without DH and to 95% with DH, due to synergies in O<sub>2</sub> and heat requirements.
- 3 Carbon is sourced from both biomass gasification and natural gas reforming in the form of CO, to reach an optimal carbon-to-hydrogen ratio in the syngas-for-methanol synthesis. Electricity’s share of energy input is further reduced to 27% compared with method 2, and internal synergies increase energy efficiency up to 71% without DH, 95% with it.

Risks arise because methanol prices are linked to oil prices, which are subject to fluctuation. However, methanol is an easily transportable and widely used commodity, so at market price there is little risk of not finding a buyer. However, opportunities to build a plant near all three grids (district heating, power and natural gas) and a readily available supply of biomass, at the 100 MW-scale, are extremely limited.

Interestingly, this business case makes no attempt to take into account the renewable aspect or lifecycle carbon footprint of the methanol produced, since no subsidies or incentives are assumed. The plant is set to operate continuously.

Figure 234: Simplified project layouts

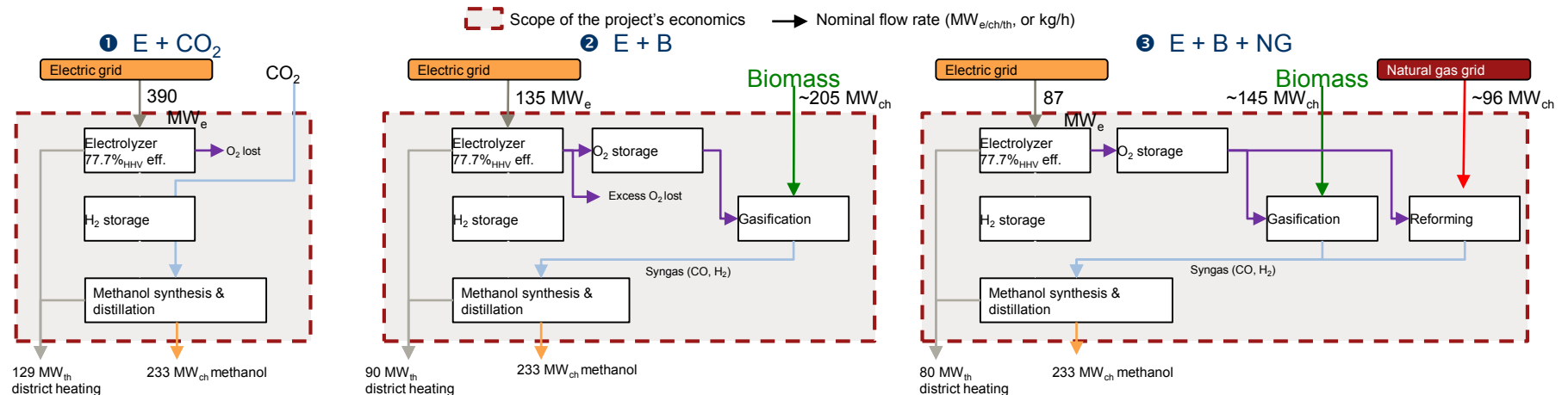

Note: Project layouts are simplified: e.g. heat recycling circuits and compressors are not represented here. Source: A.T. Kearney Energy Transition Institute, adapted from Clausen et al (2010).

# Electrolyzers have a role to play in bringing the costs of synthetic methanol close to wholesale market prices

Figure 235 shows the levelized cost of methanol required to ensure a positive net present value for each project. Sensitivity to grid-electricity costs is shown in figure 236. Qualitative results are summarized in the table.

- **Using a pure CO<sub>2</sub> stream – even at relatively low costs – is hardly profitable.** It is twice as costly, at present in Denmark, when combined with biomass. It is also highly sensitive to the price of electricity. In fact, none of the three configurations had neared cost competitiveness using assumed feedstock prices at the time of the study.
- **Adding natural gas reforming to the electrolysis-assisted biomass-to-methanol plant appears to be a good option.** It spreads feedstock-cost risks between three fuels, and, since reformers are three times cheaper than biomass gasifiers, it also reduces capital costs. Finally, selling heat for district heating raises the cost-competitiveness of synthetic methanol from 14% to 17%.

It is important to note that, since the time of this study, methanol, wood-pellet biomass and natural gas wholesale prices have increased by about 110%<sup>2</sup>, 100%<sup>3</sup> and 50%<sup>4</sup> respectively. At the same time, electricity spot prices have fallen by 10%, greatly improving the cost-competitiveness of electrolysis-assisted synthetic methanol plants. To improve cost-competitiveness further, the renewable (or low-carbon) content of synthetic methanol could be taken into account in its selling price, as discussed in case study No. 1. **Certified renewable methanol is already being sold at a premium price in Europe** from the George Olah Renewable Methanol Plant (see Section 2.5).

	Pros.	Cons.
<b>E + CO<sub>2</sub></b>	<ul style="list-style-type: none"> <li>• Operating flexibility (regulating ability for the grid)</li> </ul>	<ul style="list-style-type: none"> <li>• Highest costs</li> <li>• Lower efficiency</li> <li>• Reliability of CO<sub>2</sub> source?</li> </ul>
<b>E + B</b>	<ul style="list-style-type: none"> <li>• Total recycling of C in biomass</li> </ul>	<ul style="list-style-type: none"> <li>• Excess of O<sub>2</sub></li> </ul>
<b>E + B + NG</b>	<ul style="list-style-type: none"> <li>• Total recycling of C and O</li> <li>• Lowest cost</li> <li>• Reduced feedstock risks</li> </ul>	<ul style="list-style-type: none"> <li>• Fossil fuel input</li> </ul>

**Figure 235: Levelized cost of methanol as a function of the price of electricity**

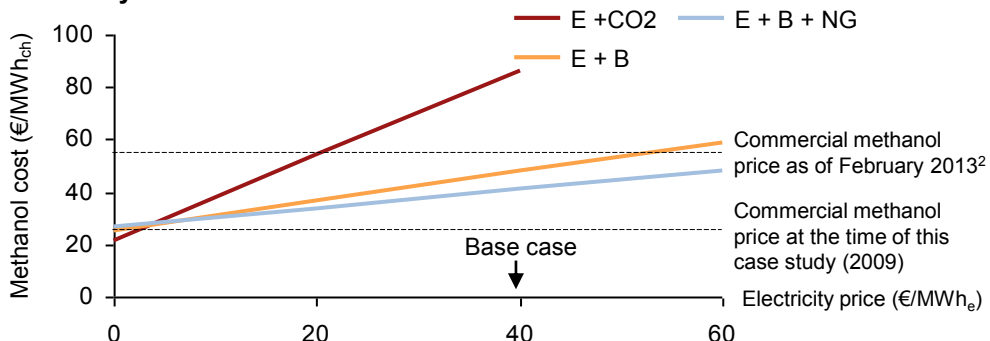

**Figure 236: Breakdown of levelized cost of methanol for electricity price at €40 /MWh<sub>e</sub> (base case)**

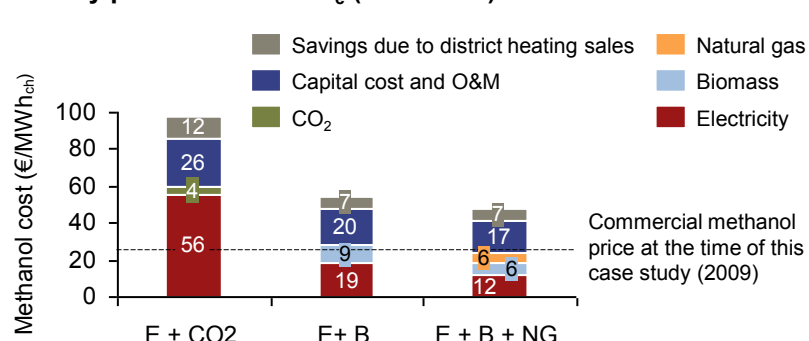

1. Although not shown here, the cost of electrolyzer + natural gas (E + NG) configuration lies between that of E+B and E+B+NG. NG is the only referenced technology, whose cost is reflected in the commercial methanol price. 2 \$0.26/L on the international spot market, as of February 2013; 3 Index PIX (Pellet Nordic Index) – Sept 2012 4 European Energy Exchange, April 2013. Source: A.T. Kearney Energy Transition Institute, adapted from Clausen et al (2010). Hydrogen-based energy 210

# Case study No. 6: back-up systems for reliable power supply to remote communities, powered by renewables and diesel imports – lessons learned from four operating projects

- The following case study compares four existing pilot projects, where a hydrogen-based energy storage system has been added to an intermittent-based power system in order to ensure power autonomy for a remote community not connected to the main electricity grid.
- Various studies have already evaluated the economics of replacing diesel imports with electricity storage for intermittent-based autonomous systems in remote communities. This analysis focuses solely on projects that have selected hydrogen as a storage medium. It summarizes the lessons learned from these first-of-a-kind initiatives and, where possible, discusses the economics of using hydrogen instead of batteries or imported diesel for reliable power supply.

## Characteristics of operating pilot projects for hydrogen-based back-up power systems in for remote or island locations (ranked by system size)

### The PURE Project

“Promoting Unst Renewable Energy”



- **Location:** Unst island, UK
- **Year:** operated 2005-11
- **Electricity source:** dedicated wind turbine
- **Storage system:** hydrogen-based
- **System size:**
  - 1 building served
  - 30 kW<sub>e</sub> wind turbines
  - 12 kW<sub>ch</sub> alkaline electrolyzer
  - 5 kW<sub>e</sub> fuel cell

#### • Credits for the case study:

Pureenergycenter (2012), “Promoting Unst Renewable Energy (PURE) project - From wind to green fuel”

### Utsira

Wind-hydrogen project



- **Location:** Utsira island, Norway
- **Year:** operated 2004-08
- **Electricity source:** wind turbine and existing grid as contingency plan
- **Storage systems:**
  - Flywheel for short-term (<1 min) power quality
  - Hydrogen-based to ensure reliable power supply for up to three days
- **System size**
  - 10 households served
  - 600 kW<sub>e</sub> wind farm
  - 36 kW<sub>ch</sub> alkaline electrolyzer
  - 10 kW<sub>e</sub> fuel cell + 55 kW<sub>e</sub> hydrogen combustion generator
  - 8 MWh<sub>ch</sub> H<sub>2</sub> tank storage
  - 100 kW<sub>e</sub> flywheel system
- **Credits for the case study:**  
IPHE (2011), “Renewable Hydrogen report - Utsira wind power and hydrogen plant”

### Ramea

Wind-hydrogen-diesel project phase 3



- **Location:** Ramea Island, Canada
- **Year:** operation started 2009
- **Electricity source:** dedicated wind turbine and diesel generator
- **Storage system:** hydrogen-based
- **System size:**
  - 631 inhabitants served
  - 925 kW<sub>e</sub> diesel generators
  - 690 kW<sub>e</sub> wind
  - ~120 kW<sub>ch</sub> electrolyzer
  - 16 MWh<sub>ch</sub> storage tanks
  - 250 kW<sub>e</sub> hydrogen generators
- **Financing:** 75% by grants; 25% utility financed
- **Credits for the case study:**  
IRENA (2012), “Electricity storage and renewables for island power – a guide for decision makers”

### HARP

“Hydrogen Assisted Renewable Project”



- **Location:** Bella Coola, Canada
- **Year:** operation started 2010
- **Electricity source:** dedicated run-of-river plant and diesel generator
- **Storage systems:**
  - Flow battery for short-term (<5min) power quality
  - Hydrogen-based electricity storage for longer-term electricity storage
- **System size:**
  - 1,900 inhabitants served
  - 6.2 MW<sub>e</sub> diesel
  - 2.12 MW<sub>e</sub> hydropower
  - 125 kW<sub>e</sub> flow battery
  - 200 kW<sub>ch</sub> alkaline electrolyzer
  - 100 kW<sub>e</sub> fuel cell
  - 4 MWh<sub>ch</sub> compressed H<sub>2</sub> storage
- **Credits for the case study:**  
Powertech Labs Inc. (2010); “Hydrogen Assisted Renewable Power (HARP) Project in British Columbia”

# Although proved technically feasible, such projects are unlikely to be driven by private initiatives in the near future

Figure 237 describes key lessons learned from each pilot. The limited number of projects prevents generalizations, but feedback so far tends to show that:

- Hydrogen-based back-up power systems have been proved technically feasible up to the MW scale, and optimization software has been successfully designed;
- Risks remain very high: technological risks are shown by the numerous start-up problems encountered by the projects, especially in re-electrification. O&M issues are especially delicate in remote places, where accessibility and qualified staff are limited;
- In economic terms, further improvements are needed before hydrogen can compete with diesel imports as back-up for wind or run-of-river intermittent production. The four projects do not show if alternative storage technologies could be more competitive. Although costly, hydrogen might be the only option for a 100% autonomous, variable, renewable-based system due to its unique storage duration capacity; and
- Public incentives and guarantees remain indispensable for overcoming risks that are, at present, unacceptable to private investors; and Pilot projects have received local public support and yielded positive results beyond the scope of the original project, such as in private R&D initiatives.

## Figure 237: Lessons learned from operating pilot projects of hydrogen-based back-up power systems for remote or island locations

### The PURE Project

1. Technically speaking, the PURE project has been a success, although the efficiency of the conventional alkaline electrolyzer was limited and energy input was intermittent. PEMs were not yet mature enough to be used in 2005.
2. In economic terms, the best use for temporary excesses of wind electricity was to power thermal storage systems for heating the building rather than converting it to hydrogen.
3. Nevertheless, electrolyzers enable 18% more wind energy to be used.
4. The project was seen as a milestone for hydrogen-based storage systems and fostered R&D initiatives such as the Pure Energy Center, which led to other projects and created skilled jobs.

### Utsira

1. No problem was reported by the customer.
2. The fuel cells experienced technical problems and rapid degradation, which prevented their full integration into the system.
3. Hydrogen combustion generators provided three years of reliable service, before technical problems were encountered.
4. Round-trip energy efficiency was only 20% on average.
5. These issues, combined with increased electricity use by customers over time, reduced the amount of time the project operated in stand-alone mode to 50%.
6. The cost, efficiency and durability of the system would have to be improved to make this type of project commercially viable (as of 2004).

### Ramea

1. Electrolyzers are operating well.
2. Some technical challenges with the hydrogen-fuelled generators have arisen, which are expected to be resolved soon.
3. The project's savings and economics are yet to be evaluated. It was partially funded by government grants.
4. Today, around one-third of the project's annual electricity requirements are supplied by the wind turbines. It is expected that, with additional wind turbines and the expansion of the hydrogen storage system, the project could eventually meet 90% or more of the island's total electricity needs.

### HARP

1. The system was designed to be fully automated. But following various start-up problems, it still requires frequent intervention from highly trained staff, who are not readily available.
2. Diesel fuel consumption has been reduced by about 15%.
3. The cost of adding an H<sub>2</sub> system is unlikely to be recovered by savings in diesel costs, so return on investment is unlikely to be acceptable. This is unsurprising for a pilot technology-evaluation project. But it does suggest that the capital costs of H<sub>2</sub> systems will need to fall.

# Case study No. 7: Autonomous system for PV-powered telecoms tower, in a remote location

## Assumptions

**Project type:** non grid-connected PV/battery/H<sub>2</sub>-storage system, versus PV/battery/diesel-backup

**Location:** multiple regions, with a focus on India

**Year:** 2011 and 2015 (projected)

**Plant size:** 5 kW<sub>e</sub> nominal power delivered to the telecoms tower

**H<sub>2</sub> transport:** no

**H<sub>2</sub> storage:** yes (various types)

### Main quantitative parameters for the analysis:

Uninstalled costs (electrolyzer): \$1,000 /kW in 2011; \$550 /kW in 2015

Uninstalled costs (fuel cell): \$2,000 /kW in 2011; \$550 /kW in 2015

Uninstalled costs (unitized regenerative electrolyzer/fuel-cell system): \$2,000 /kW in 2015

Uninstalled costs (diesel engine): \$800 /kW<sub>e</sub>

Energy-storage cost (battery): \$0.3 /kWh<sub>e</sub>

Energy-storage cost (metal hydride): \$2 /kWh<sub>ch</sub> in 2015, during 1,000 cycles

Energy-storage cost (pressurized tank): \$15.22 /kWh<sub>ch</sub>

Efficiency (electrolyzer) : 80%

Efficiency (long-term storage): 40%

Efficiency (battery round trip): 80%

Efficiency (diesel): 30%

System lifetime: 10 years

## Credits for the case study

Raj et al. (2012), "Standalone PV-diesel system vs. PV-H<sub>2</sub> system: an economic analysis", Arun S. Raj, Prakash C. Ghosh, Energy 42, pp. 270-280  
Federation of Indian Chambers of Commerce and Industry – FICCI and A.T. Kearney (2012), "Green telecom: the way ahead industry inputs for the proposed national telecom policy"

# H<sub>2</sub>-based storage systems compensate for intermittent PV electricity generation instead of diesel generators

This case study examines the conditions under which autonomous PV/H<sub>2</sub> systems can compete with PV/diesel for very small-scale applications (5 kW), without subsidies. In both cases, electrochemical batteries are required to overcome the short-term supply variations of solar electricity generation, but they do not compensate for the seasonal mismatch of PV output in high-latitude regions, which is managed by diesel generators. Long-term storage provided by H<sub>2</sub>-based systems could remove the need for these generators, however (figure 238). Compressed-air-storage alternatives are excluded from this analysis, because they are uneconomic below the MW scale.

The sensitivity criteria in this analysis are: on-site diesel cost in \$ per liter; and seasonal insolation variations<sup>1</sup> – a critical factor for the H<sub>2</sub>-storage size or diesel requirement. A single seasonal solar insolation variation is defined for every remote location. As a rule of thumb, low-latitude regions (close to the equator) have the lowest seasonal variations, but are subject to large weather events, such as monsoons. The critical fuel cost, above which H<sub>2</sub>-based systems can compete with diesel, can be estimated for each seasonal variation. A boundary curve delineates where the two systems are equally cost-effective (figure 239).

In a second phase, various types of H<sub>2</sub>-based storage system are analyzed: compressed-gas versus metal-hydrates storage; proton-exchange-membrane fuel cells, versus H<sub>2</sub> internal combustion engines [ICE]; and pressurized electrolyzers, vs unitized regenerative-electrolyzer/fuel-cell systems.

Figure 238: Simplified project layouts

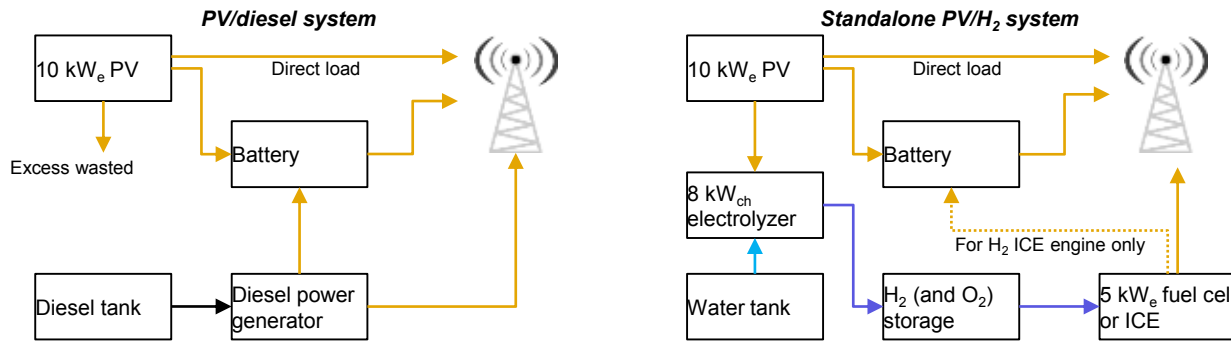

The battery is as small as possible to avoid loss of load. Both the PV farm and the diesel generator are connected to the battery, to enable full-load operation and optimal energy efficiency. Excess energy is wasted and greenhouse gases are emitted. The main contributor to life-cycle expenditure is fuel cost.

Battery-storage dimensions are similar to those in the PV/diesel case, and given a higher priority over H<sub>2</sub>-storage because it has higher round-trip efficiency. The H<sub>2</sub> power generator is connected to the battery only if it is an H<sub>2</sub>-ICE engine, which has low energy efficiency at partial load. The initial investment is the main contributor to lifecycle cost.

Figure 239: Variation of critical fuel cost with seasonal solar energy difference (schematic)

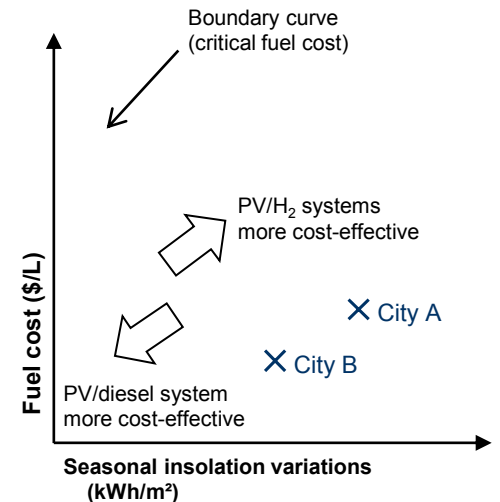

1. The seasonal insolation variation (Ediff in kWh/m<sup>2</sup>) is calculated by dividing the year in two parts: the higher and the lower solar-energy months. Ediff equals the cumulated solar energy received per surface area during the six highest months, minus the cumulative of the six lowest months.

Source: Raj et al. (2012).

# H<sub>2</sub> is a cost-effective solution for remote PV-powered telecoms towers in high latitude regions and utilization could extend worldwide by 2015

The results in figure 240 are based on commercially available proton exchange membrane fuel cells and compressed-H<sub>2</sub> storage systems. The boundary curves have been adapted slightly by country to account for inflation and discount rates. They suggest **H<sub>2</sub>-based systems are a good alternative to diesel in Japan, France or North America; but not yet in India or China, where seasonal solar variations are too small and fuel prices too low to justify seasonal storage.**

Figure 241 shows projected economics in India for 2015, with reduced component costs, increased fuel costs for various H<sub>2</sub>-based system configurations, and platinum recycling from fuel-cell electrodes. **It demonstrates that, in the near future, H<sub>2</sub> can compete with diesel to fuel telecoms towers in India, if targeted cost and performance are achieved.** More precisely, the best H<sub>2</sub> system configuration would be a unitized regenerative electrolyzer/fuel cell, in conjunction with metal-hydride storage. H<sub>2</sub> internal combustion engines are much less cost-effective than fuel cells, but are not represented here.

**This analysis argues that PV/H<sub>2</sub> systems for small-scale applications could be a pertinent alternative to PV/diesel in most regions by 2015.** In contrast, case study No. 6 showed that the economics of H<sub>2</sub>-storage for autonomous, remote communities powered by MW-scale, run-of-river or wind power are still uncertain, compared with traditional diesel back-up systems. The reasons are that: sun-produced electricity requires much longer storage time than wind, because of seasonal variations; and diesel generators are less well adapted to very small systems.

**These results must be viewed with a degree of skepticism: they do not account for improved battery performance by 2015; and results are conditional on the use of PV,** whose competitiveness must be assessed against standalone alternatives such as wind. **Interestingly, the locations where H<sub>2</sub> seasonal storage is most competitive (high solar variation/high latitude regions) might not be the most suitable for PV,** because annual average insolation is low. Small wind turbines are more relevant to the telecom tower in Fort Nelson, Canada, than PV, for example; and wind does not require seasonal storage systems, making H<sub>2</sub> systems useless.

**Figure 240: Variation of critical fuel cost required for PV/H<sub>2</sub> system to compete with PV/diesel system (2011, for various countries)**

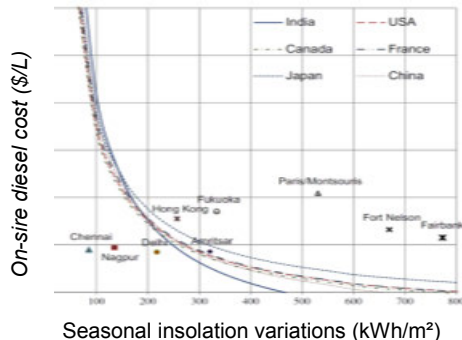

**Figure 241: Variation of critical fuel cost in India for various H<sub>2</sub>-system configurations (2015)**

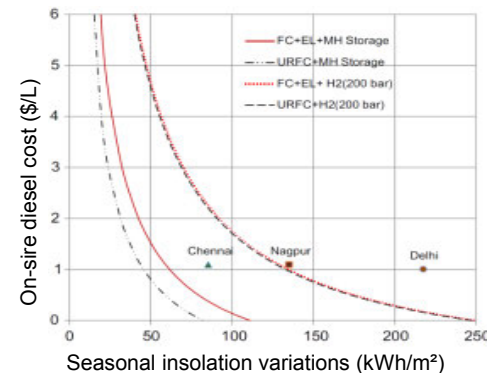

Note: FC+EL: separated fuel cell + electrolyzer; URFC: unitized regenerative electrolyzer- fuel cell. MH: metal hydrides storage system.  
Source: Raj et al. (2012).

## India is one of the largest markets for PV-powered telecoms towers, although the competitiveness of H<sub>2</sub>-based seasonal storage will be an obstacle in the short term

India is arguably the largest market for autonomous telecoms towers (figures 242 and 243), where fast-spreading infrastructure is overly reliant on diesel, because of inadequate or non-existent electricity grids. And with **diesel theft increasing their consumption by 10-20%**, telecoms companies<sup>1</sup> and PV-system operators are increasingly pushing for fuel-saving solutions.

**It is estimated that the market for H<sub>2</sub>-based storage systems for remote telecoms towers in India could be worth \$8.4-16 million per year, from 2015.** And the size of this market could double if the share of PV as an energy source for new towers also doubles by 2015:

- By 2012<sup>2</sup>, most of India's 800,000 telecoms towers – or Base Transceiver Stations [BTS] – were in rural and semi-urban areas, with 18% off-grid. In 2011, 60% of the 5.7 TWh<sub>e</sub> power required for BTS was met by diesel generators: 73.1% operated on a combination of diesel generators and batteries; 19.6% on diesel generators exclusively; and 7.4% (11,600) on PV/battery/diesel system.
- BTS are being installed at a staggering growth rate of 14% a year between 2010 and 2015, an average of 80,000 new BTS per year. Most are in rural and semi-urban areas, where PV-based systems are increasingly competitive<sup>1</sup>. A very conservative forecast, based on the assumption that the proportion of off-grid PV-powered BTS remains constant (1.4%), leads to 1,200 new installations a year until 2015. For these, H<sub>2</sub>-based storage systems could start to compete with diesel back-up around 2015<sup>2</sup>. It represents an annual market size of 2.8-5.7 MW<sub>ch</sub> of installed H<sub>2</sub>-production capacity<sup>3</sup>, with \$3,000 /kW<sub>ch</sub> of installed capital costs<sup>3</sup>; a market size of \$8.4-16 million a year, starting around 2015.

**This case study suggests that off-grid, remote telecoms towers could be a good market for H<sub>2</sub>-based storage systems in the near future. But its limited size makes it a niche market compared with other potential applications of electrolytic hydrogen.**

Figure 242: Diesel engine powering a telecoms tower in India<sup>4</sup>



Figure 243: PV-powered telecoms tower in India<sup>4</sup>



# Case study No. 8: Bulk electricity storage, for inter-day price arbitrage

## Assumptions



**Project type:** bulk electricity storage, for inter-day price arbitrage

**Location/Year:** US, 2009, currency: \$(2008)

**Plant size:** 50 MW<sub>e</sub> discharging rate required, 6 hours per weekday

**H<sub>2</sub> transport:** none

**H<sub>2</sub> storage:** yes (compressed tank, or salt cavern)

**Main quantitative parameters for the analysis:**

Feedstock costs

Electricity cost: \$38 /MWh<sub>e</sub> (corresponding to off-peak periods)

Natural gas cost for compressed-air energy-storage systems: \$7 /million British thermal units [MBTu]

Alkaline electrolyzer

Installed capital cost: \$830 /kW<sub>e</sub>, \$450 /kW<sub>e</sub>, and \$340 /kW<sub>e</sub> (high-, medium-, low-cost cases, respectively)

Efficiency (HHV): 73%, 81%, and 87% (high-, medium-, low-case, respectively)

PEM fuel cell

Installed capital cost: \$3,000 /kW<sub>e</sub>, \$813 /kW<sub>e</sub>, and \$434 /kW<sub>e</sub> (high-, medium-, low-case, respectively)

Efficiency (HHV): 39.5%, 44.5%, and 48.7% (high-, medium-, low-case, respectively)

H<sub>2</sub>-fueled gas turbine

Installed capital cost: \$1,000 /kW<sub>e</sub>, \$1,000 /kW<sub>e</sub>, and \$800 /kW<sub>e</sub> (high-, medium-, low-cost case, respectively)

Efficiency (HHV): 35.2% (above-ground tank storage for the high-cost case), 59% (underground storage for the medium- and low-cost cases)

Energy-storage cost (above-ground compressed tank): \$160 /MWh<sub>ch</sub>

Energy-storage cost (salt caverns): \$17 /kWh<sub>ch</sub> for solution-mined; \$140 /kWh<sub>ch</sub> for dry-mined

Discount rate: 10%, with plant life of 40 years

## Credits for the case study

The case study is based on National Renewable Energy Laboratory – NREL (2010), “1–10 kW Stationary Combined Heat and Power Systems Status and Technical Potential”.

# Price-arbitrage storage systems must be able to operate daily cycles, with relatively large power and energy capacities

**This case study compares the ability of H<sub>2</sub>-based storage systems to take advantage of inter-day electricity-price arbitrage opportunities, with that of commercial alternatives:** pumped hydro storage, compressed air energy storage and large scale batteries. Electricity is available for 18 hours a day and during the weekend at a fixed, off-peak cost of \$38 /MWh<sub>e</sub>. It is stored, then discharged during peak-demand periods (weekdays, from 1-7pm) at 50 MW<sub>e</sub> (figure 245).

**Three cost scenarios are evaluated:** high-cost case (existing installed systems in 2009); mid-range case (near future); and low-cost case (fully mature technology with bulk manufacturing, according to US DoE targets). The levelized cost of electricity discharged is then calculated, which gives the peak-hour price required to justify investment. Noticeably, no value is assigned to grid-stabilization services, which could also be met by the same systems.

**Storage systems (H<sub>2</sub>, batteries, pumped hydro storage [PHS]) are designed to deliver 50 MW<sub>e</sub> of electricity, for six hours each week day.** This requires 300 MWh<sub>e</sub> of energy capacity and 50 MW<sub>e</sub> of power-generating capacity for all systems, except possibly H<sub>2</sub>, because charging and discharging power capacities can vary. The ideal H<sub>2</sub> system configuration comprises: an undersized – therefore, less costly – charger (30 MW<sub>e</sub>); coupled with an oversized energy-storage reservoir (1.6 TWh<sub>e</sub>), which can be entirely filled during the weekend (figures 244 and 245).

**Although beyond the scope of this study, it is pertinent to question whether demand exists for such storage systems.** Some countries already use hydro-power capacity in reverse mode at night to avoid costly ramp-up and -down of baseload nuclear capacity, because PHS systems are highly efficient, and incur only marginal investments once the plant is built. Rising wind-power capacity will also, on average, reduce the residual off-peak demand load. Additionally, installed price-arbitrage capacity can destroy its own business model, by reducing price differences.

**Figure 244: Layout of H<sub>2</sub>-based storage system**

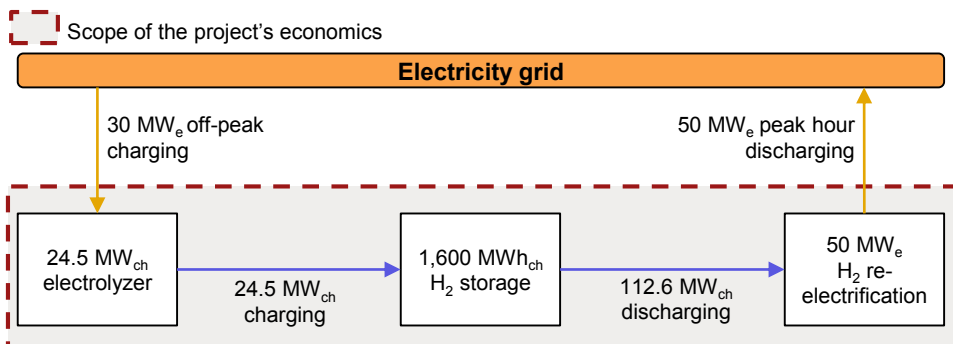

Each of the three H<sub>2</sub> system configurations are evaluated, using three cost scenarios:

1. PEM fuel cell with aboveground compressed H<sub>2</sub> tank storage (high-, mid-, and low-cost case)
2. PEM fuel cell with geological storage (high-, mid-, and low-cost case)
3. Hydrogen turbine with geological storage (mid- and low-cost case), or with compressed tank (high-cost case)

**Figure 245: Evolution of H<sub>2</sub> stored in a week**

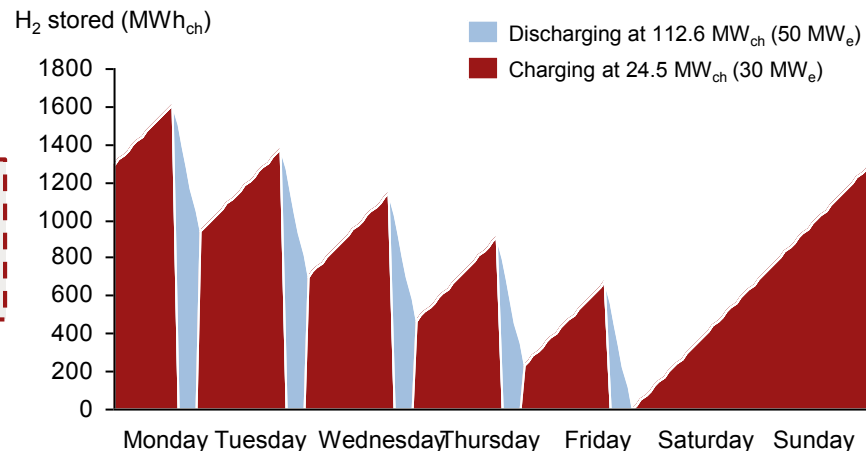

1. Three-to-five-year forecasts, as of 2009. Figures 244 and 245 are based on the mid-range cost scenario, and fuel cell/geological storage system configuration. Source: NREL (2009).

# Globally, hydrogen may be able to compete with batteries for daily cycling in the near future; but not in locations suitable for CAES, or pumped hydro technologies

Whichever technology is used, intraday price arbitrage presents challenging economics (figure 246). The cheapest systems are pumped hydro storage [PHS] and compressed air energy storage [CAES], which require a minimum peak and off-peak price gap of at least \$92 /MWh<sub>e</sub> and \$62 /MWh<sub>e</sub>, respectively<sup>1</sup>.

Because these technologies are geographically constrained, for locations where neither is possible, H<sub>2</sub>-based systems are the cheapest alternative, followed closely by Sodium-Sulfur batteries and Vanadium Redox flow batteries. The range of levelized cost of output electricity [LCOE] from an H<sub>2</sub>-based system is very large, reflecting the relative immaturity of fuel-cell and electrolysis technologies. H<sub>2</sub> turbines are more mature and should remain the best H<sub>2</sub> re-electrification option, according to the NREL's cost forecasts, but the competition remains open: combustion turbines can provide additional flexibility to utilities, through co-firing a mixture of H<sub>2</sub> and natural gas; while the dynamic power response of proton exchange membrane fuel cells and potential breakthroughs in high-temperature solid oxide fuel cells (not evaluated here) could provide additional grid-stabilization services. Salt-formation storage is the cheapest hydrogen option, but this is still more costly than compressed-air storage in the same formation.

Figure 247 shows that systems with low storage efficiencies are highly sensitive to the price of electricity used for charging. H<sub>2</sub> systems, with the lowest round-trip efficiency (35-48%, mid-cost case) can no longer compete with batteries when off-peak electricity prices are high. This proves that H<sub>2</sub> systems are better suited to grids with a high penetration of intermittent, renewable power capacity.

Efficient fuel cells reduce not only energy losses, but also the required size (and capital cost) of upstream components (H<sub>2</sub> storage, electrolyzers).

**Figure 246: Range of levelized cost of output electricity from storage**

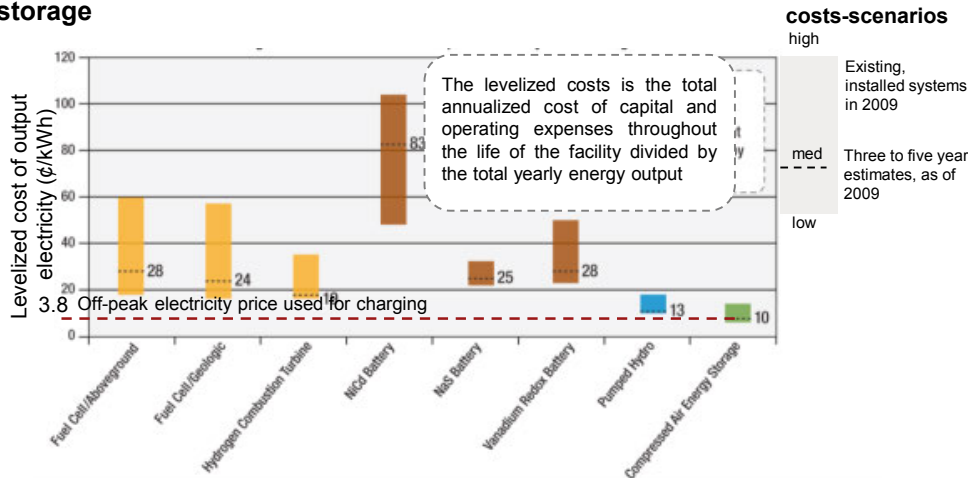

**Figure 247: Electricity price sensitivity vs. round-trip storage efficiency**

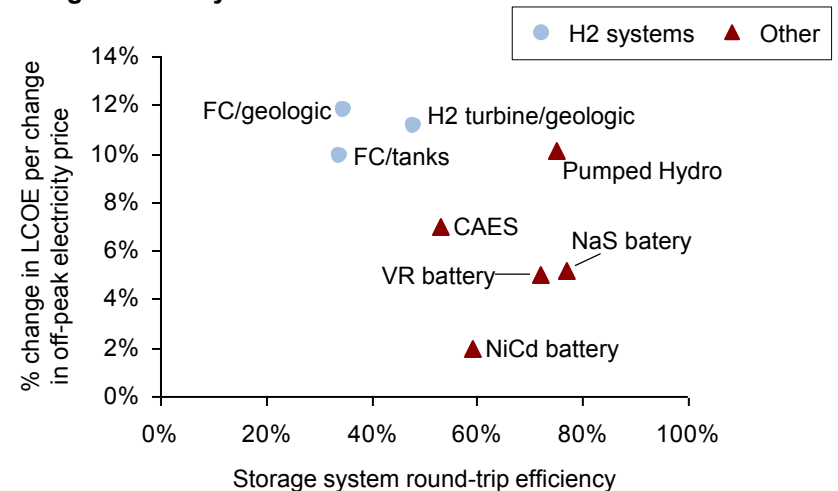

1. The minimum peak and off-peak price gap is calculated as the difference between the off-peak electricity price used for charging (3.8¢/kWh) and the levelized cost of output electricity from the medium-cost scenario (13 ¢/kWh for PHS and 10 ¢/kWh for CAES), as illustrated by figure 246.

Source: NREL (2009).

# Case study No. 9: Long-term, grid-scale electricity storage in the German Energiewende

## Assumptions

**Project type:** country-wide power-system analysis:

Forecast of the need for grid-scale electricity storage in Germany

Techno-economic analysis of corresponding storage systems

**Location/Year:** Germany, from present day until 2050

**Storage system size:** hundreds of MW, hundreds of GWh stored, for weeks to months

**Assumptions:** highlighted throughout the case study

## Credits for the case study

The following case study was collated by A.T. Kearney Energy Transition Institute by summarizing, interpreting and cross-analyzing the output of various studies:

Institute of Energy Economics and the Rationale Use of Energy – IER (2013), *“The system effects and electricity market impacts of the energiewende policy in Germany”*;

Zentrum für Energieforschung stuttgart – ZFES (2012): *“Stromspeicherpotenziale für Deutschland”*, Institut für Energiewirtschaft und Rationelle Energieanwendung (IER); Institut für Strömungsmechanik und Hydraulische Strömungsmaschinen (IHS); Zentrum für Sonnenenergie- und Wasserstoff-Forschung Baden-Württemberg (ZSW);

Conseil International des Grands Réseaux Electriques – CIGRE (2008), *“Energy storage for improved operation of future energy supply systems”*, Martin Kleimaier et al; based on VDE-Study, *“Energy storage in power supply systems with a high share of renewable energy sources”*.

# Four energy-mix scenarios outline the lowest-cost pathway to fulfill Germany's *Energiewende* objective of 80% renewable electricity by 2050

Germany's ambitious energy-transition plan (*Energiewende*) aims for a low-carbon, renewable energy system by 2050. In the electricity sector, the objective is for renewable generation to rise from a 22% share today<sup>1</sup> to 80% by 2050. By 2022, the country will have shut down all 12 GW of its operating nuclear plants<sup>2</sup>. **The following case examines the impact of German's *Energiewende* on the power grid in order to quantify the need for long-term, grid-scale electricity storage.** In a second step, a techno-economic analysis assesses whether hydrogen could meet those needs. Because of the long-term nature of such analyses, the results should be taken as orders of magnitude rather than detailed capacity, or generation forecasts.

**Four scenarios are considered, named by the percentage of electricity generated from renewables** (figure 248). RE-15% is close to the German power system pre-*Energiewende*; while RE-80% is the best mix for achieving the *Energiewende*'s objectives. Common assumptions for each scenario include, among others<sup>3</sup>: fixed energy demand of 550 TWh; no possibility of exports/imports; and a substantial number of electric-vehicle batteries, providing 48 GW of fast cycle (~1 hour) charging/discharging capacity (they do not replace the potential need for longer-term storage).

Electricity supply and the energy mix are shown in figure 249. **For all scenarios, excess generation of 16-21 TWh (or, 2-4% of demand) implies a need for exports, curtailment or storage.** With low intermittent penetration rates, excess supply results from optimization of the power fleet, utilizing intraday price arbitrage through pumped hydro storage plants or battery-powered vehicles. Higher intermittent penetration increases surplus supply; but each additional TWh of excess does not require an additional TWh of storage capacity, because several storage cycles per year are operated. A dynamic analysis of electricity supply vs. demand has been undertaken to assess the required total storage capacity (next slide).

**Figure 248: Installed capacity forecasts, excluding storage (2050)**

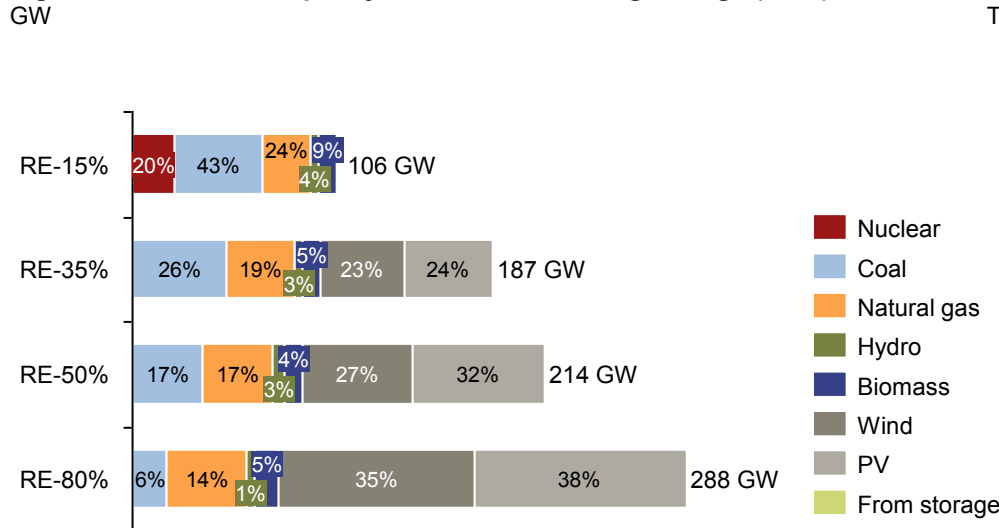

**Figure 249: Electricity generation forecasts (2050)**

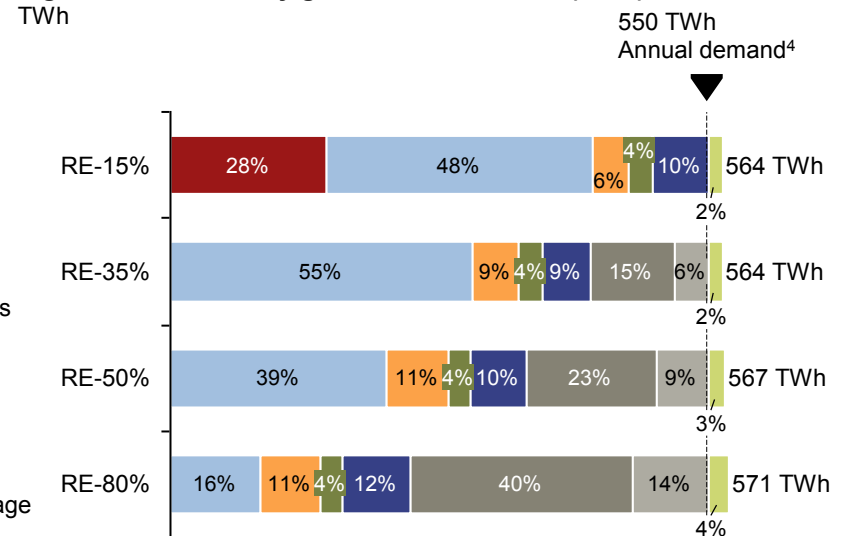

3. Fuel prices of coal and gas corresponds to projections of IEA World Energy Outlook 2010 "New policies scenario" for the year 2030, and a CO2-allowance price set at €50 /ton of CO2; 4including grid losses, excluding energy stored.

Source: Case study by IER (2013); 1AG Energy Balance (March 2013); 2World Nuclear Association (April 2013).

# With renewables holding less than a 50% share of Germany's power mix, it is difficult to justify the need for additional large-scale storage systems, other than pumped-hydro

Dynamic analysis of electricity supply and demand with stochastic inputs from wind and solar PV sources was undertaken for each scenario. **Figure 250 illustrates the results of a typical year under RE-50% and RE-80%.** The residual load (demand minus intermittent supply) that must be matched by flexible power sources is shown in red. **Figure 251 summarizes the resulting electricity prices and storage needs.**

- **RE-15% and RE-35%** (not shown here): **residual load remains positive** and no storage, other than the battery-vehicle fleet, is necessary.
- **RE-50%:** intermittent penetration equals 33%. Annual PV + wind surplus amounts to 2 TWh, leading to 200 hours of electricity prices at €0 on the spot market. Monetizing this excess would require a storage system of 417 GWh (energy) and 10.8 GW (power). Present and planned PHS capacity in Germany (80 GWh and 7.6 GW)<sup>1</sup>, along with interconnections to adjacent markets should provide sufficient storage capacity – **H<sub>2</sub>-storage systems would not be required.**
- **RE-80%:** intermittent penetration reaches 55%. Annual PV + wind surplus reaches 43 TWh, leading to almost 3,000 hours (35% of the year) of free electricity on the spot market. Monetizing these excesses would **require a storage system of 6.4 TWh and 48 GW.** The cost-optimal solution would be to install only 2 TWh and 30.8 GW of storage and curtail what could not be exported. (The following slide details potential uses of large-scale storage technology.)

**In the medium term, it is difficult to justify the need for new large-scale storage systems in Germany.** In the long run, additional storage may also compete with market interconnection and the large pumped-hydro potential of Nordic countries (which has not been considered here). This study highlights the effect of intermittent penetration on electricity costs: it lowers the annual average spot price, by increasing periods of low-cost electricity; and it increases grid-level system-integration costs, which is not reflected in the spot price and could be significant (not shown in this study).

**Figure 250: Typical annual demand and residual load pattern**

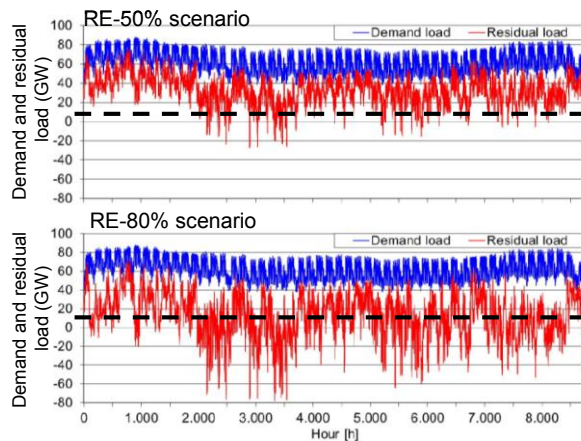

**Figure 251: Forecasted effect of high renewable penetration in the German electricity system**

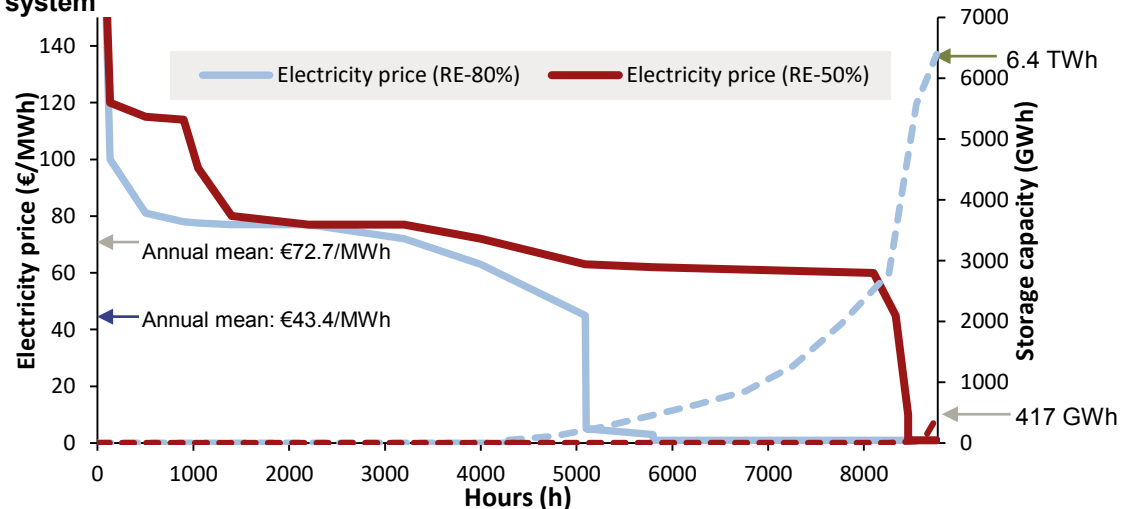

# When the penetration of renewables in the German energy mix reaches 80%, H<sub>2</sub> will become the best storage solution because of a shortage of pumped-hydro storage capacity

The IER (2013) case study in the previous slides states an ultimate storage need of 2 TWh (optimal) to 6.4 TWh (maximal). Other comprehensive studies of the *Energiewende* quote storage capacities between 1 TWh (SRU 2011, UBA 2010) and 20-40 TWh (FVEE 2010, DLR 2010).

Technically, 2 TWh is the upper limit of PHS potential in Germany<sup>1</sup> (figure 253). Additional storage capacity will most likely be needed. But more than 20% of the storage capacity available to the German power grid already comes through interconnection to foreign PHS plants; and, with an estimated potential of 27 TWh from planned underground caverns, CAES could fulfill most of those additional needs.

Economically, CAES might not be suited to the monthly cycling required when there is a high penetration of wind power: two independent studies identify CAES as a more expensive alternative to PHS than H<sub>2</sub> systems – the only competitor (figure 252). Storing H<sub>2</sub> underground in the form of methane, instead of pure hydrogen, will be around 40% more expensive, but might offer other advantages: it could be coupled with the natural gas grid to optimize the capacity factor of the plant, or utilize existing underground gas-storage facilities.

Germany's pure-H<sub>2</sub> storage potential in existing salt caverns is vast, but power-to-gas technologies also offer significant potential through the country's highly developed gas infrastructure: without building any new caverns, around 1.7 TWh of energy could be stored underground in the form of H<sub>2</sub>-enriched natural gas, with an H<sub>2</sub> blending volume of 5% (see Section 2.4); and 380 TWh of energy could be stored as synthetic methane in the natural gas caverns and grid line-pack.

**Figure 252: Levelized cost of electricity output for monthly storage systems**  
€/MWh, without charging costs

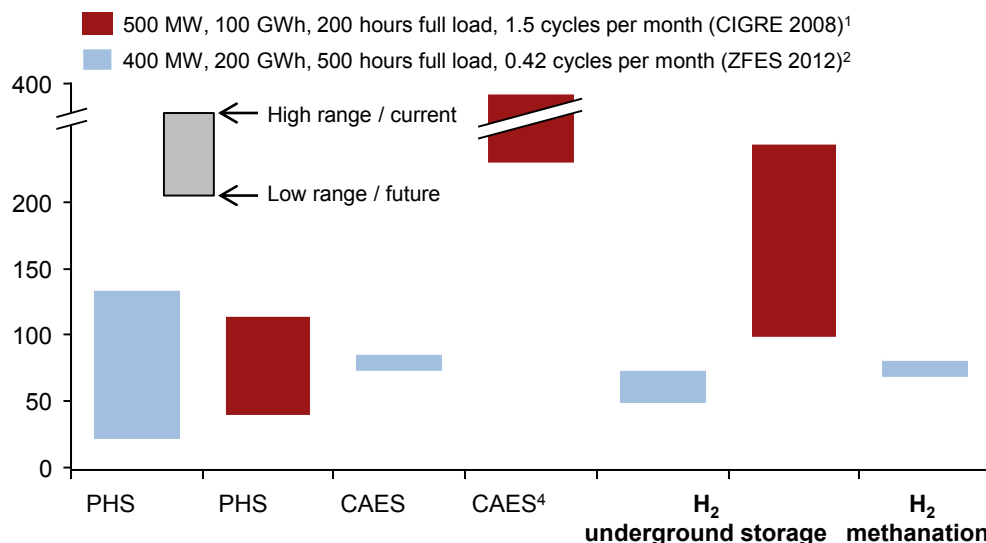

**Figure 253: Potential for electricity storage system in Germany (ZFES 2012)<sup>2</sup> TWh**

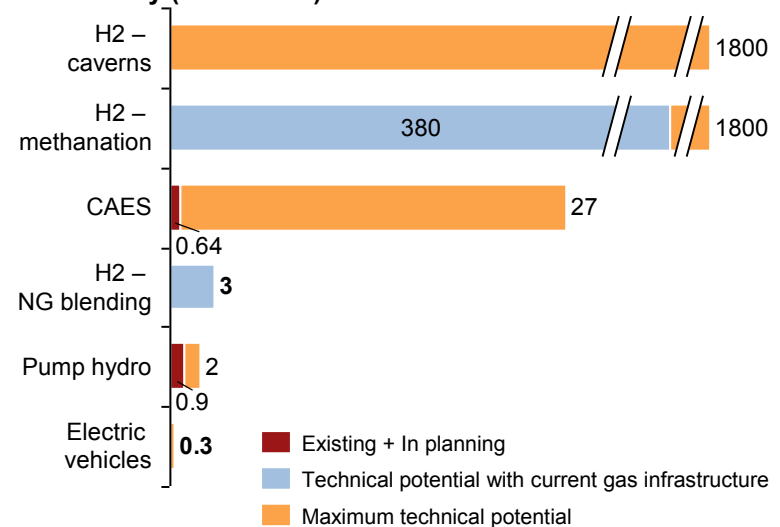

1. TWh is a more realistic estimate, given public-acceptance issues ; 2Discount rate 8%; €2008; low range = five to ten years “achievable costs” at mass production; high range = state of the art at the time of the study; 3Methanation refers to power-to-SNG storage system, with underground storage and gas turbine for re-electrification; 4Adiabatic CAES, only has been considered

## Sources: section 3.2

- Argonne (2011), *“Liquid hydrogen production and delivery from a dedicated wind power plant”*, Amgad Elgowainy, Marianne Mintz, Darlene Steward, Olga Sozinova, Daryl Brown, Monterey Gardiner
- Conseil International des Grands Réseaux Electriques – CIGRE (2008), *“Energy storage for improved operation of future energy supply systems”*, Martin Kleimaier et al; based on VDE-Study, *“Energy storage in power supply systems with a high share of renewable energy sources”*, <http://www.vde.com/de/fg/ETG/Arbeitsgebiete/V1/Aktuelles/Oeffentlich/Seiten/VDE-StudyEnergystorage.aspx>
- Clausen et al. (2010), *“Technoeconomic analysis of a methanol plant based on gasification of biomass and electrolysis of water”*, Lasse R. Clausen, Niels Houbak, Brian Elmegaard, Energy 35, pp. 2338-2347
- German Aerospace Center – DLR (2010) *“Langfristszenarien und strategien für den ausbau der erneuerbaren energien in Deutschland bei berücksichtigung der entwicklung in europa und global”*
- Federation of Indian Chambers of Commerce and Industry – FICCI and A.T. Kearney (2012), *“Green telecom: the way ahead industry inputs for the proposed national telecom policy”*
- Forschungsverbund Erneuerbare Energien Energiekonzept – FVEE(2010), *“Eine Vision für ein nachhaltiges Energiekonzept auf Basis von Energieeffizienz und 100% erneuerbaren Energien”*
- Gazey et al. (2006), *“A field application experience of integrating hydrogen technology with wind power in a remote island location”*, Ross Gazey, Salman K. Salman, Daniel Aklil-D’Halluin, Journal of Power Sources, Vol.157, pp. 841–847
- International Renewable Energy Agency – IRENA (2012), *“Electricity storage and renewables for island power – a guide for decision makers”*
- Institute of Energy Economics and the Rationale Use of Energy – IER (2013), *“The system effects and electricity market impacts of the energiewende policy in Germany”*
- International Partnership for Hydrogen and Fuel Cells in the Economy – IPHE (2011), *“Renewable Hydrogen report - Utsira wind power and hydrogen plant”*, [http://www.iphe.net/docs/Renew\\_H2\\_Ustira.pdf](http://www.iphe.net/docs/Renew_H2_Ustira.pdf)
- Jørgensen et al. (2008), *“Production price of hydrogen from grid connected electrolysis in a power market with high wind penetration”*, Claus Jørgensen, Stephanie Ropenus
- Mansilla et al. (2013), *“Economic competitiveness of off-peak hydrogen production today – A European comparison”*, Christine Mansilla, Jeremy Louyrette, Sandrine Albou, Cyril Bourasseau, Séverine Dautremont, Energy (2013), <http://dx.doi.org/10.1016/j.energy.2013.03.022>
- Mansilla et al. (2012), *“Electric system management through hydrogen production – A market driven approach in the french context”*, Christine Mansilla, Jeremy Louyrette, Sandrine Albou, Cyril Bourasseau, Nathalie Collignon, Séverine Dautremont, Julien Martin, Françoise Thais, International Journal of Hydrogen Energy, vol. 37, pp. 10986-10991
- Mohseni et al. (2012), *“The competitiveness of synthetic natural gas as a propellant in the Swedish fuel market”*, Farzad Mohseni, Martin Görling, Per Alvfors, Royal Institute of Technology
- National Renewable Energy Laboratory – NREL (2010), *“1–10 kW Stationary Combined Heat and Power Systems Status and Technical Potential”*
- Pureenergycenter (2012), *“Promoting Unst Renewable Energy (PURE) project - From wind to green fuel”*, <http://www.pureenergycentre.com/pureenergycentre/Pureprojectcasestudy.pdf>

## Sources: section 3.2 continued

Raj et al. (2012), “Standalone PV-diesel system vs. PV-H2 system: an economic analysis”, Arun S. Raj, Prakash C. Ghosh, Energy 42, pp. 270-280

Sachverständigenrat für Umweltfragen – SRU (2011), “Wege zur 100 % erneuerbaren Stromversorgung”

Umweltbundesamtes – UBA (2010), “Energieziel 2050: 100% Strom aus erneuerbaren Quellen Umweltbundesamt”, Thomas Klaus, Carla Vollmer, Kathrin Werner, Henry Lehmann, Klaus Müschen

Powertech Labs Inc. (2010); “Hydrogen Assisted Renewable Power (HARP) Project in British Columbia”, Allan Grant, Powertech Labs Inc, Bobby Sagoo, GE Digital Energy, [http://der.lbl.gov/sites/der.lbl.gov/files/vancouver\\_grant-sagoo.pdf](http://der.lbl.gov/sites/der.lbl.gov/files/vancouver_grant-sagoo.pdf)

Zentrum für Energieforschung stuttgart – ZFES (2012): “Stromspeicherpotenziale für Deutschland”, Institut für Energiewirtschaft und Rationelle Energieanwendung (IER); Institut für Strömungsmechanik und Hydraulische Strömungsmaschinen (IHS); Zentrum für Sonnenenergie- und Wasserstoff-Forschung Baden-Württemberg (ZSW)



## Section 4

### Environmental impact, safety & social acceptance

# Summary & key findings: section 4

## 1. Environmental impact:

- *Air pollution & climate change.* The conversion of variable renewable electricity to hydrogen incurs few environmental challenges. In general, hydrogen-storage solutions result in lower emissions than other energy-storage technologies, although their full lifecycle pollutants and GHGs emissions depend on the primary energy source and power-production technology.
- *Land use.* Land use is also very unlikely to be a constraint on hydrogen-based conversion solutions, although renewable-based systems could face problems because of their land requirements. Electrolyzing modules require a minimum surface area (typically around 75 m<sup>2</sup>/MW of H<sub>2</sub>, as low as 16.7 m<sup>2</sup>/MW for PEM). When hydrogen is used to enrich biofuel production by recycling excess of CO<sub>2</sub>, it is actually maximizing the land use of bioenergy.
- *Water use.* Electrolytic hydrogen production consists of splitting water [H<sub>2</sub>O] into its constituent elements (hydrogen and oxygen), using energy from an electric current. Although it requires a constant supply of water, the net water consumption of electrolysis is relatively low: around 250-560 liters per MWh of hydrogen produced. When combined with renewable electricity, water consumption is lower than in other low-carbon power generation technologies. In addition, re-electrification using reverse electrolysis releases water. Cooling water may be circulated to maintain an optimum temperature, to counterbalance the heat produced as a result of resistance in the electrode during the electrolytic reaction.

## 2. Safety concerns:

- *Molecular structure.* Hydrogen raises safety issues because of its flammable and explosive nature. Hydrogen molecules are very small and light, allowing them to infiltrate materials and damage their internal structure, but they also react with some geological formations suitable for underground storage of other gases. This can lead to gas escaping and accumulating in confined spaces, creating risk of fire and explosion.
- *Flammable & explosive gas.* Similarly to methane or gasoline vapor, hydrogen is flammable. In the presence of an oxidizing agent and of an inflammation source, it ignites. And hydrogen is more volatile than other because of its broader range of flammability limits (it can ignite even when highly concentrated) and to the very low energy ignition needed, especially for high concentration, in which cases a spark or a flame can be sufficient. Hydrogen flames emit less heat radiation, however, limiting the risk of secondary fires and reducing danger to the public; and, as a result of its high diffusivity, hydrogen fires are vertical, so remain localized, as well as being non-toxic. The risks are relatively limited in open-air conditions, where hydrogen quickly rises and dilutes into a non-flammable concentration. But, in confined spaces, it may lead to high concentrations at the top of the installation, increasing the risk of explosion and fire. Finally, unlike most gases, which generally cool when they expand, hydrogen compressed at ambient temperature heats up when it expands to atmospheric pressure. On its own, this is unlikely to lead to spontaneous ignition, but has to be borne in mind due to its possible combination with other effects.
- *Detection.* Hydrogen is colorless and odorless, and the addition of an odorant is not possible because of the gas's small molecular size. It is virtually undetectable to humans. Consequently, hydrogen leaks are difficult to detect, and safety regimes are more stringent. Sensors are crucial in preventing incidents. Although they exist and are used in industry (chromatography and spectrometry techniques), the technologies are very bulky and expensive, and cannot reliably distinguish between hydrogen and methane molecules. A history of false readings makes them impractical for a wide deployment of hydrogen solutions, making them impractical for a wide deployment of hydrogen solutions. Further research is needed into sensors, testing facilities and certification.

## Summary & key findings: section 4 continued

### 3. Safety concerns continued :

- *Regulation, codes and standards.* International collaboration is essential for the development of harmonized regulation, codes and standards to govern hydrogen-storage solutions. Hydrogen has a history of safe use in the chemicals and petrochemicals industries, where it is handled by trained personnel in a similar way to other fuels. End-users are subject to stringent regulation, which may be over-protective. A growing industry will require new, more flexible regulations. Codes and standards are slowly being developed to ensure the safety of hydrogen applications. These also serve to reassure the public that efforts are made to ensure safe operations and can help to bring about social acceptance, as well as heightening awareness of the risks and benefits that accompany hydrogen technologies.

### 4. Social acceptance:

- The use of hydrogen as an energy carrier is relatively new and, as such, may be vulnerable to inaccurate public perception. Social acceptance is vital to the successful deployment of any technology. It can be achieved by heightening awareness of the risks and benefits offered by hydrogen technologies, through: education, providing information on safety and emphasizing the environmental advantages of hydrogen as a fuel.

## 4.1 - Environmental impact: air, land & water





# Conversion of surplus power into H<sub>2</sub> faces few environmental challenges

The harnessing of temporary excesses of electricity produced from variable renewable electricity supply, through chemical conversion to hydrogen, maximizes the utilization of wind and solar electricity generation. It also provides an alternative electricity source during peak-demand periods, or when wind or solar generation are not available, other than power plants that emit carbon. **Consequently, the effects on the environment of producing renewably sourced hydrogen are a crucially important consideration. They include, but are not limited to, controlling greenhouse-gas [GHG] emissions.**

**Environmental assessments focus on three areas: air pollution & climate change**, including GHG emissions, but also local air pollution from sulfur oxide, nitrous oxide or particulate matter, which are a health risk to humans; **land use** – an important consideration for storage solutions given that wind and solar farms are already criticized for their land footprint; and use of **water**, which, in the case of electrolysis (where hydrogen is produced from water), is the main feedstock, along with electrical energy.

On this basis, **the conversion of surplus intermittent electricity into hydrogen has few environmental consequences.** Environmental impact is dependent on the technology generating the primary energy source: solar photovoltaic [PV] has a greater environmental footprint than wind because of the manufacturing process for PV cells. Energy storage developments, meanwhile, could provide a solution to renewables' intermittency. But this is system specific, and outside the scope of this section.

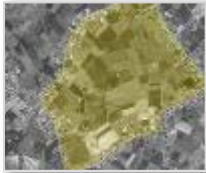
**Figure 254: Summary of environmental impacts of hydrogen-based storage of intermittent renewable electricity**

<b>AIR POLLUTION</b>		<p>Converting solar and wind power into H<sub>2</sub> through electrolysis has a slightly detrimental effect on air pollution, both in terms of GHG emissions and local air pollution, through acidification. Any potential impact on the atmosphere resulting from an escape of H<sub>2</sub> gas is negligible.</p>
<b>LAND USE</b>		<p>Land-occupation by H<sub>2</sub> production and storage capacity is insignificant compared with land requirements for renewable-energy production in a wind or solar-PV farm. Electrolyzer modules require a small surface area and can be installed along with, and be integrated into, the area being used for renewable-energy production – between wind turbines, for example.</p>
<b>WATER REQUIREMENTS</b>		<p>The net water consumption of the electrolysis reaction is relatively low, with a typical water feed of 250-560 liters per MWh of produced H<sub>2</sub>. When combined with electricity produced from wind and solar, water consumption is even lower than that of other low-carbon power-generation technologies. Additionally, re-electrification, using reverse electrolysis, produces water as a by-product.</p>

# Converting solar and wind power into H<sub>2</sub> has a limited detrimental effect on air pollution, in terms of GHG emissions and local air pollution

The electrolytic conversion of temporary excesses of renewable electricity into H<sub>2</sub> creates no direct GHG emissions, or other pollutants. But the full lifecycle of H<sub>2</sub>-based solutions does have an environmental impact resulting mainly from the generation of the electricity stored and from the construction and decommissioning of the storage facility (e.g. manufacturing of electrolyzer cells).

When feedstock electricity is generated from fossil fuels, the low round-trip efficiency of the hydrogen storage value-chain results in higher GHG emissions than most alternatives. However, renewables-based H<sub>2</sub>-storage solutions emit fewer emissions per energy content than other bulk energy-storage technologies. Less energy is required for the construction and operation of hydrogen storage plants than for pumped hydro storage, compressed air energy storage and batteries<sup>1</sup>.

Life Cycle Analysis [LCA] demonstrates that the environmental impact of converting temporary excesses of electricity produced from solar and wind energy sources into H<sub>2</sub> is very low in terms both of GHGs and acidification potential (the contribution of air pollutants to acid deposition in the environment, resulting in acid rain). Disregarding nuclear power, the environmental performance of wind-based electrolytic hydrogen<sup>2</sup> outshines all other technologies considered. And although solar PV's impact is greater, the LCA result is still significantly lower than that of steam methane-reforming and coal gasification.

**Figure 255: Comparative life-cycle carbon emissions (left) and acidification potential (right) of hydrogen-production technologies<sup>4</sup>**  
 gCO<sub>2</sub>eq. /kWh produced, gSO<sub>2</sub>eq./ MWh produced

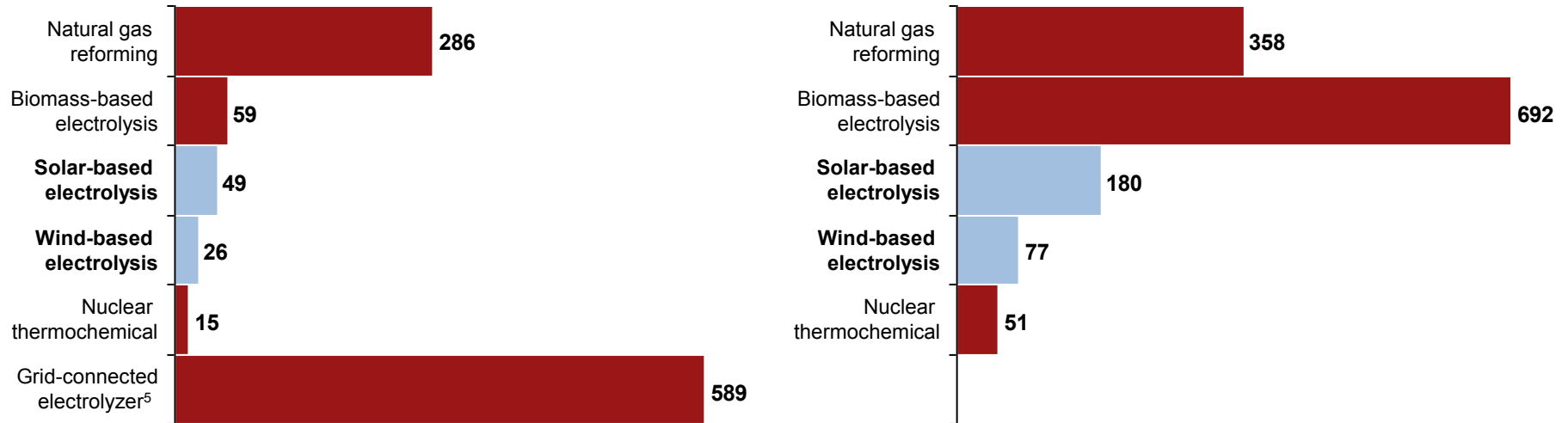

1. According to Denholm et al. total GHG emissions resulting from the construction and operation of conventional PHS, CAES and battery-storage plants – excluding emissions resulting from electricity storage – are around 5.6, 292 and 32.6 tons CO<sub>2</sub>eq per GWh, respectively. Note that new CAES concepts would significantly reduce GHG emissions, which are mainly caused by the use of gas to reheat air upon decompression; <sup>2</sup>Using SOEC; <sup>3</sup>US Environmental Protection Agency (2009); <sup>4</sup>Colella et al. (2005) based on U.S. energy mix; <sup>5</sup>Dincer et al. (2011)

# Potential H<sub>2</sub> leaks would have a negligible effect on atmospheric GHG concentrations

Hydrogen is a tropospheric ozone precursor – similar to nitrogen oxide [NO<sub>x</sub>], methane, and carbon monoxide – and is also known as an indirect GHG. An excess of hydrogen resulting from potential leaks could lead to increased atmospheric concentrations of indirect GHGs<sup>1</sup>, undermining, albeit only slightly, the recovery of the ozone layer (figure 256).

As a contributor to global warming, however, its impact is thought to be negligible. Assuming an extreme situation, with a 10% leak rate in a fully H<sub>2</sub>-based economy<sup>2</sup>, the climate impact would be equivalent to only 6% of the present system, because H<sub>2</sub>'s global-warming potential is just 5.8 over a 100-year period<sup>4</sup>.

Figure 256: Atmospheric reactions resulting from hydrogen release<sup>5</sup>

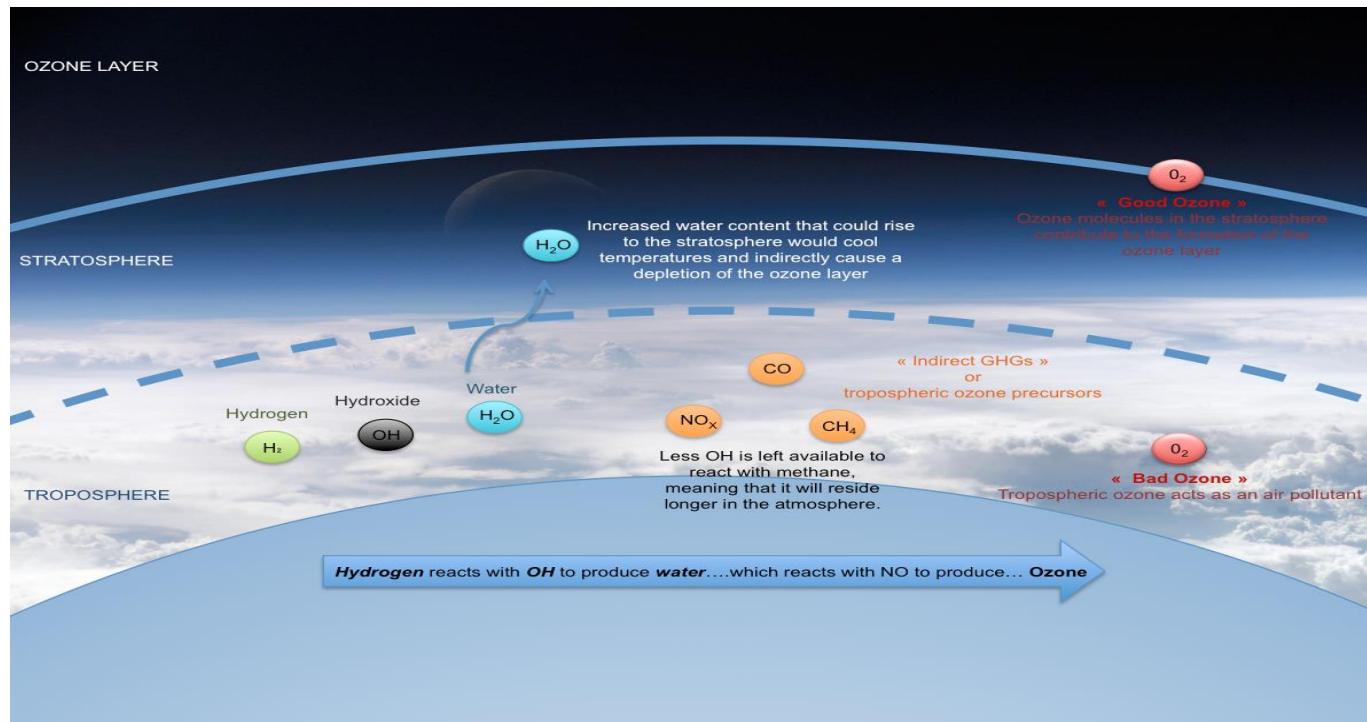

1. The concentration of indirect GHGs is expected to decay with a folding time similar to the lifetime of H<sub>2</sub>. Quantitatively, this is estimated to be 2.5 years for an observed H<sub>2</sub> burden of 182 megaton [Mt] and a global sink strength of 74.4 Mt/year; <sup>2</sup>For an estimated H<sub>2</sub> production capacity of 2,500 Mt/year, its global-warming potential is estimated to be equivalent to 150 Mt CO<sub>2</sub>/year.; Source: Tromp et al. (2003);<sup>4</sup>Derwent (2006); <sup>5</sup>based on Schultz et al. (2003).

# Land use for H<sub>2</sub>-based solutions is low compared with the footprint of wind and PV installations

Deploying H<sub>2</sub>-based storage solutions alongside wind or solar farms would require increased land use for these renewable technologies. Because of the immaturity of H<sub>2</sub> technologies; the multitude issues concerning H<sub>2</sub> operating pressure and temperature; and the nature of electrolysis and stackable fuel cells, **it is hard to assess accurately whether land-occupation of H<sub>2</sub>-based solutions would raise significant concerns.**

Land footprint can be estimated based on existing facilities commercialized by manufacturers, such as Hydrogenics, NEL, Areva or McPhy. Most offer stand-alone modules, composed of: an alkaline electrolysis skid (including the cells and the balance of plants); a storage device (usually compressed tanks at 350 bar, or solid metal hydride); and a fuel cell. **The land footprint varies minimally between producers – typically around 75 m<sup>2</sup>/MW of hydrogen capacity (figure 258).** Future **PEM electrolyzers will have a smaller footprint, however, using 16.7 m<sup>2</sup>/MW, although producing on a smaller scale.**

As shown by figure 257, H<sub>2</sub>-solution land use compared with a wind farm is 75% lower than the land occupied by the turbine pads alone. The maximum instantaneous excess of renewable capacity in Germany is estimated at 48 GW by 2050 (see Section 3.2, business case No. 9); only 3.6 km<sup>2</sup> of land would be needed for this amount with current H<sub>2</sub>-storage modules installed in parallel. So, **land use is very unlikely to be a constraint on H<sub>2</sub>-based storage solutions alone; although a fully renewable system could face challenges to the land use of renewable-energy production.**

**Figure 257: Illustrative land-use comparison to produce an average of 1 GW of renewable electricity**

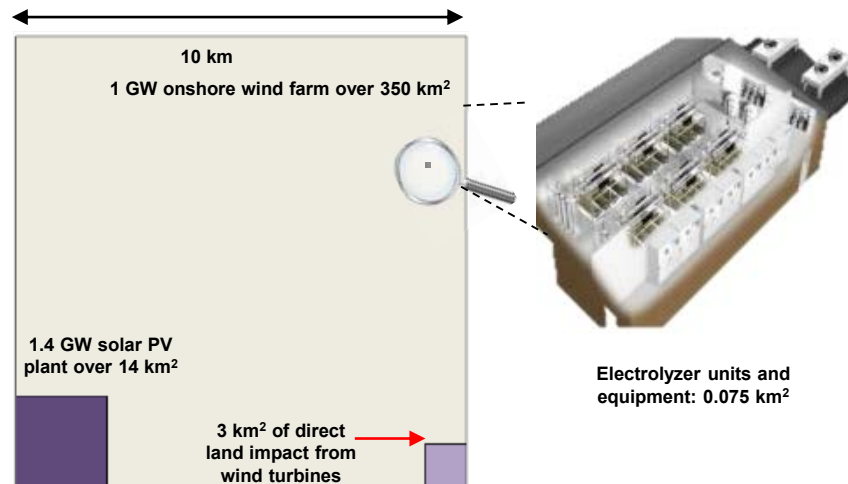

**Figure 258: Examples of land requirements of technologies m<sup>2</sup>/MW**

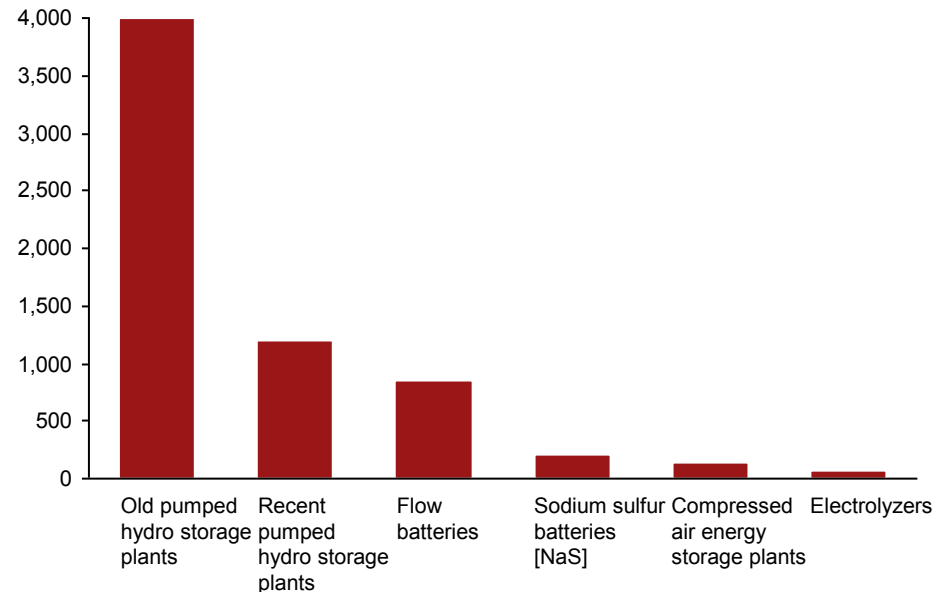

# The net water consumption of electrolysis is relatively low thanks to recycling systems

**The water requirement of electrolysis is an important factor to consider in an environmental-impact assessment of H<sub>2</sub> solutions.** Electrolysis consists of splitting water (H<sub>2</sub>O) into its constituent elements, Hydrogen (H<sub>2</sub>) and Oxygen (O<sub>2</sub>), using energy from an electric current. Whether we can afford to dedicate enough water (a valuable resource) to electrolysis has been raised by several opponents, such as Ulf Bossel in Germany.

**In the course of H<sub>2</sub> production, water is required as a feedstock and for cooling** (figure 260):

- *Direct:* pure water is mixed with an electrolyte, from which H<sub>2</sub> is extracted. Feedstock water will not be recovered in the process. Research is investigating the use of seawater for electrolysis, but its prospects are uncertain. Nearly all water consumed in the process can be recovered through inverse electrolysis or direct combustion – fuel cells, for example, would make it a near water-neutral system; and
- *Indirect:* water is used to produce the electricity needed for electrolysis, but also for purifying the water feedstock that is to be used in electrolysis (e.g. deionizers and reverse osmosis equipment<sup>1</sup>). According to the US Geological Survey, in 2000, nearly all of the water used by these plants was returned to the source (although at a higher temperature and with a different quality). By utilizing evaporation towers, a closed-loop circuit can limit water withdrawal. Renewable-power sources, such as wind or solar, do not require a coolant. Water may also be used in a closed loop for cooling the electrolyzer – heat is generated by resistance in the electrode during the electrolytic reaction.

**Despite these uses, net water consumption remains relatively low** (figure 259). Studies of commercialized alkaline electrolyzers show a typical water feed of 250-560 L/MWh of H<sub>2</sub> produced. Most of the water circulated is used for cooling – around 70,000 L/MWh – but this requirement can be virtually eliminated by using a closed-loop circuit. Water consumption is also a function of the efficiency of the electrolysis plant. **When combined with electricity produced from wind and solar, total water consumption is still lower than alternative low-carbon power-generation technologies**, such as hydropower, geothermal, or coal with carbon capture and storage. Additionally, re-electrification in fuel cells (or reverse electrolysis) produces water.

**Figure 259: Net water consumption<sup>2</sup>, electrolysis vs. power plants** L/MWh<sub>e</sub> for power plant vs. MWh<sub>ch</sub> for electrolysis

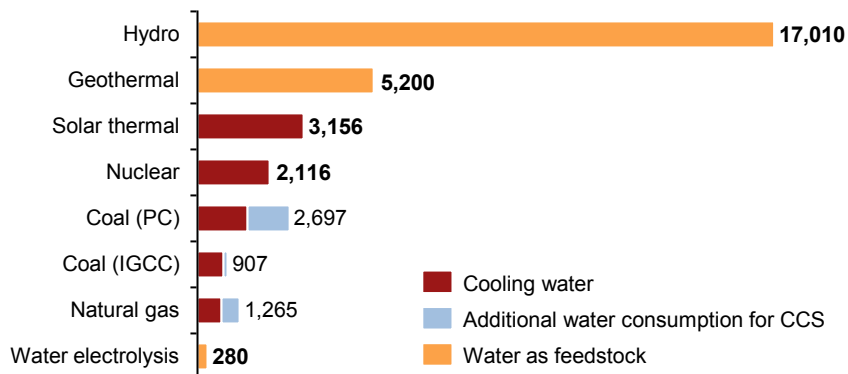

**Figure 260: Flow chart of a typical commercial electrolyzer Electrogenics model<sup>3</sup>**

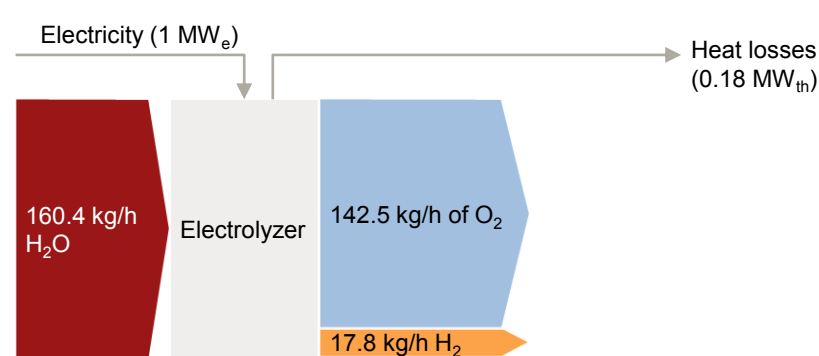

1. Purifying units recover only a limited portion of the water entering the system. The remainder is discharged as waste water; 2Water consumption refers to water that is used (for crop irrigation, for example), as opposed to water withdrawal, which refers to water extracted for a given use, but returned to source. Thermal power plants and water electrolysis in this dataset use closed-loop cooling systems with evaporating cooling towers. Electrolysis is a 2 MW alkaline electrolyzer unit; 3A.T. Kearney Energy Transition Institute analysis, based on Hydrogenics; Mielke et al. (2010); DoE; Bossel (2006).

## Sources: section 4.1

- Bossel (2006), “*Does an hydrogen economy makes sense?*”, Proceeding of the Institute of Electrical and Electronics Engineers Vol. 94, pp. 1826-1837
- Colella et al. (2005), “*Switching to a US hydrogen fuel cell vehicle fleet: The resultant change in emissions, energy use, and greenhouse gases*”, Withney Colella, Mark Jacobson, David Golden, Journal of Power Sources, vol. 150, pp. 150–181
- Denholm et al (2004), “*Life cycle energy requirements and greenhouse gas emissions from large scale energy storage systems*”, Paul Denholm, Gerald Kulcinski, Energy Conversion and Management, vol. 45, pp. 2153–2172
- Derwent (2006), “*Global environmental impacts of the hydrogen economy*”, Richard Derwent, International Journal of Nuclear Hydrogen Production and Application, vol. 1
- Dincer et al. (2012), “*Comparative life cycle assessment of hydrogen and other selected fuels*”, Ibrahim Dincer, Kevork Hacetoglu, Marc A. Rosen, Faculty of Engineering and Applied Science, University of Ontario Institute of Technology, International Journal of Hydrogen Energy, vol. 37
- Dincer et al.(2011), “*A comparative life cycle analysis of hydrogen production via thermochemical water splitting using a Cu-Cl cycle*”, Ibrahim Dincer, Marc A. Rosen, Ahmet Ozbilen, International Journal of Hydrogen Energy, vol. 36
- Dincer et al. (2006), “*Environmental and economic aspects of hydrogen production and utilization in fuel cell vehicles*”, Ibrahim Dincer, Marc A. Rosen, Mikhail Granovskii, Journal of Power Sources, vol. 157, pp. 411-421
- Hydrogenics (2012), “*Hystat hydrogen generators*”
- Mielke et al. (2010), “*Water consumption of energy resource extraction, processing, and conversion*”, Erik Mielke, Laura Diaz Anadon, Venkatesh Narayanamurti, Energy Technology Innovation Policy Research Group, Harvard Kennedy School
- NEL Hydrogen, “*NEL P-60 pressurized electrolyzers*”
- Schultz et al. (2003), “*Air pollution and climate-forcing impacts of a global hydrogen economy*”, Martin Schultz, Thomas Diehl, Guy Brasseur, Werner Zittel, Science, New Series, vol. 302, pp. 624-627
- Tromp et al. (2003), “*Potential environmental impact of a hydrogen economy on the stratosphere*”, Tracey Tromp, Run-Lie Shia, Mark Allen, John Eiler, Y.L. Yung, Science, New Series, vol. 300, pp. 1740-1742
- Webber (2007), “*The water intensity of the transitional hydrogen economy*”, Michael E Webber, Environmental Research Letters, vol. 2

## 4.2 - Safety: risk & mitigation options



# Safety issues arise from hydrogen’s small and light molecular composition, and flammable, explosive nature

Hydrogen is a versatile fuel with a history of safe industrial use. But it has a reputation as a dangerous substance to a general public that once dubbed it flammable air.

All fuels can be hazardous and hydrogen is neither an exception, nor intrinsically more dangerous – by understanding its behavior, we know how to handle it. Although hydrogen’s particularities are well understood, more research is needed to fully comprehend its interaction with other substances and the extent of potential effects. This is particularly true in the case of underground storage, where hydrogen may encounter and react with substances in ways that we can only learn to anticipate and control.

H<sub>2</sub> molecules are very small and light, allowing them to infiltrate materials and damage their internal structure. This can lead to gas escaping and accumulating. Because hydrogen is highly flammable under certain conditions, this can give rise to potentially hazardous situations. But all fuels are combustible and all pose safety threats – it is simply a matter of applying sufficient safety protocols. Safety sensors are continuously improving; while codes and standards to ensure the safe operation of hydrogen systems are already in place, and continue to develop.

Figure 261: Summary of safety issues associated with hydrogen use

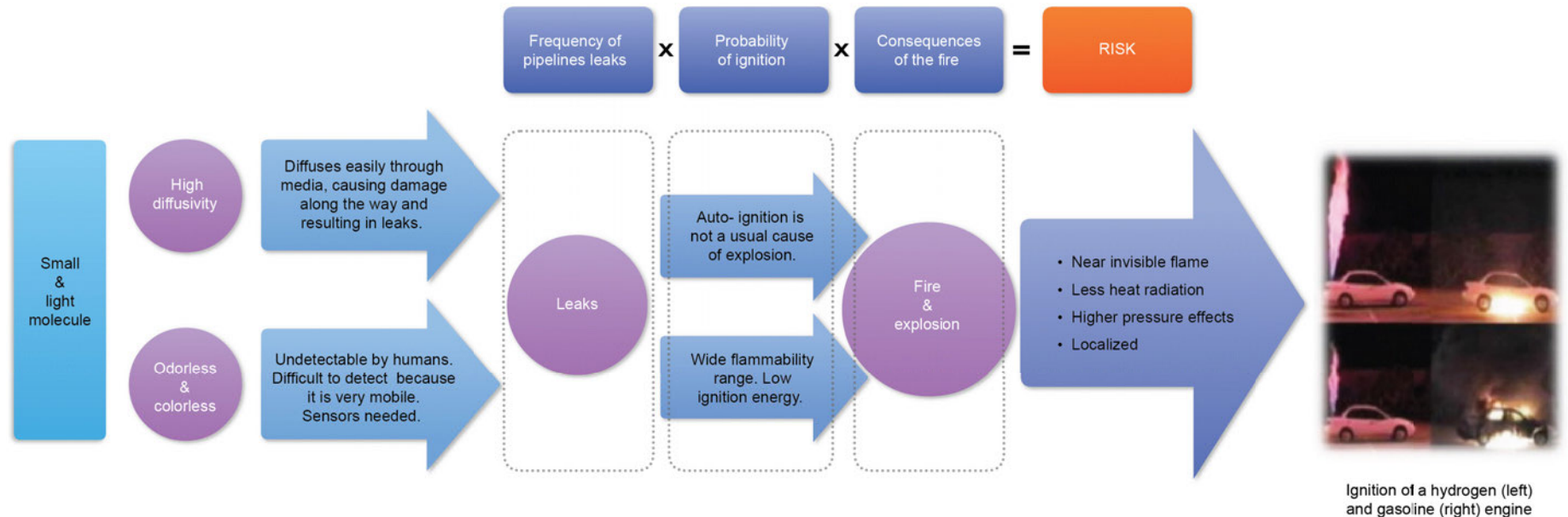

# Atomic hydrogen can penetrate the microstructure of materials, reducing their ability to deform under stress, and ultimately leading to fractures at much lower stresses than anticipated

**Because of their very small size, exposure to hydrogen molecules can damage materials used to handle them.** In theory, all materials<sup>1</sup> can be subject to embrittlement, but this issue is particularly prominent in steels and alloys. Hydrogen can cause many types of degradation, but the industry focus is on embrittlement resulting from exposure to gaseous hydrogen: the creation of internal defects through blistering; hydrogen attack; and hydride embrittlement<sup>2</sup>.

- **Blistering** (figure 263): Hydrogen molecules dissociate into atoms on the surface of the metal. Hydrogen atoms are much smaller than an iron crystal lattice, so diffuse readily into the metal. Once inside, they exploit micro-cracks and defects in the structure by accumulating, then seeking to recombine into molecules. This creates a rise in pressure and the formation of internal cracks parallel to the external surface, causing **blistering**. The magnitude of the hydrogen-induced decrease in ductility increases with strength of pipeline material; therefore, very little plastic deformation occurs in very high-strength alloys, leading to cracking rather than blistering – also known as **hydrogen-induced cracking**;
- **Hydrogen attack**: Exposure of certain materials to high-pressure hydrogen at high temperature causes absorbed hydrogen to react with alloying elements; resulting in the formation of a gas that forces the grains of the material apart; increasing pressure and resulting in cracking. Steel and copper are the two prominent targets for hydrogen attack. Hydrogen reacts with carbides in steel to produce methane, which has the double effect of reducing the strength of steel, through decarbonization, and causing cracking because of internal pressure. In copper alloys, hydrogen reacts with copper oxide to produce steam, resulting in cracking from pressure effects; and
- **Hydride embrittlement** (figure 262): In hydride-forming metals, absorbed hydrogen can precipitate as hydrides, which are themselves brittle and degrade the ductility of the alloy. This leads to cracks that propagate through the material, with more hydride progressively precipitating at the crack tip, leading to severe embrittlement.

**Although their dynamics are not perfectly understood, industry has managed to prevent these phenomena occurring in chemical and petrochemical use of hydrogen.**

**Figure 262: Schematic of the process of H<sub>2</sub> embrittlement through absorption<sup>3</sup>**

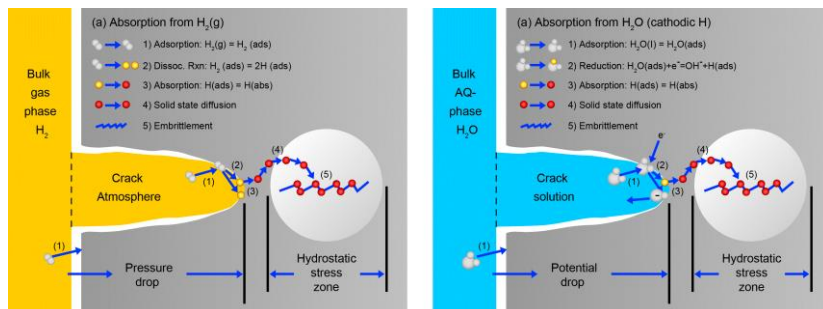

**Figure 263: Illustration of different types of steel damage**

<sup>4</sup>Hydrogen blisters in the wall of a steel container (Left); and, <sup>5</sup> Hydrogen diffusivity inside the material, forming hydrides (Right)

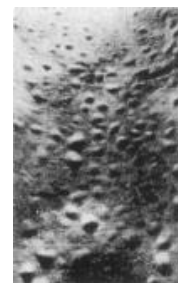

Hydrogen embrittlement occurs at points of stress concentration (hard spots, such as joints) and is expected to be a risk only for high-strength steel (superior to 100 ksi yield strength). Fracture resulting from hydrogen damage happens suddenly without any visible warning signs, and typically affects 2-3% of components

1. Pure hydrogen gas will not cause degradation of polymers; <sup>2</sup>Internal hydrogen embrittlement, resulting from hydrogen introduction during metals manufacture is not discussed here.

Source: Herring (2010);<sup>4</sup>Mostert et al (2005);<sup>5</sup>Azkarate (2010); The Fastener Engineer & Research Association (2006); EERE (2007); Louthan (2008).

# Hydrogen blending into an existing gas network may be constrained for safety reasons, but no significant risk to pipelines has been identified for concentrations below 20vol.%

The risk of damage to, and leaks from, new dedicated pipelines carrying pure hydrogen can be easily prevented. But blending hydrogen into existing natural gas pipelines is more challenging and is case-specific. Consequently, risks must be assessed locally and include field experiments. Studies in the US (for the Gas Technology Institute) and Europe (in the framework of the NaturalHy project) concluded that the extent of hydrogen damage varies according to: the pipeline system (high-pressure transmission, or low-pressure distribution); pipeline-material type; hydrogen-blending concentration; and exposure time. The blending ratios stated below refer to pipeline network safety only, and that much stricter constraints are likely to apply for end-use equipment.

- **Blending concentration.** The greater the hydrogen concentration, the lower the critical stress at which failure may occur – but this does not mean that hydrogen damage will not occur at low concentrations. The failure frequency of pipelines is thought to be unchanged, compared with that of pure natural gas pipelines, with up to 50vol.% hydrogen blending, when an appropriate integrity-management system is in place. Blending up to a 20vol.% would not necessitate modification, nor would it increase the risk of ignition or the effect on end-use systems significantly.
- **Pipeline material and system operating pressure:**
  - **Steel pipes** used in today's natural gas systems are most commonly made of low-strength steels (52 and 60 ksi), which can be seamless or welded. These are not particularly at risk of embrittlement (if the pipe is seamless, even less so, because it presents fewer hard spots). However, crack growth from existing defects may be enhanced by the presence of hydrogen and resulting pressure fluctuations in the pipeline; and
  - **Polymer** distribution pipelines allow gas permeation, which increases with pressure: low-pressure service pipelines suffer less leakage through permeation than high-pressure distribution mains. In both instances, leaks are negligible and non-hazardous.
- **Integrity and age.** Older pipeline networks can develop defects resulting from prolonged use and lower-quality manufacturing, which can be targets for embrittlement. Regular pipeline inspection is recommended to assess any potential damage.

Existing natural gas transmission pipes can carry hydrogen concentrations of up to 50% after minor adaptations to the integrity-management programs, which place emphasis on corrosion defects rather than cracks. But hydrogen concentration may need to be lower for distribution pipelines because, although these operate at lower pressure, they are closer to population concentrations where a pipeline accident could harm the public.

**Figure 264: E.ON's Falkenhagen power-to-gas pilot, Germany**

Key: parameters:

- 2 MW<sub>el</sub>
- Fed into the local gas grid (ONTRAS)

Goals:

- Gain experience in technology, costs, consent process;
- Optimize operational concepts; and
- Demonstration of the process chain.

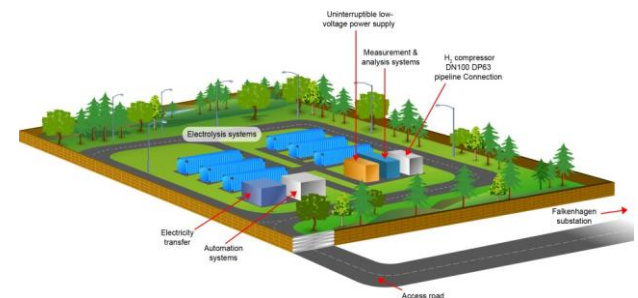

# Salt caverns are, for now, the only safe solution for storing hydrogen gas on a large scale, although the feasibility of using aquifers and depleted oil and gas reservoirs is being investigated.

The safe storage of gas in underground geological formations has long been practiced with natural gas. The industry also has some experience of storage of H<sub>2</sub> using salt caverns (figure 265) – notably in Teesside in the UK, where this has been practiced for decades. Fortunately, much of the experience with natural gas is directly applicable to H<sub>2</sub>. But H<sub>2</sub> is a small, light molecule that reacts with other elements and steel at high pressures and temperatures, and these characteristics may raise geological, geomechanical, and operational issues<sup>1</sup>.

The main uncertainty concerns H<sub>2</sub>'s reaction with the geological formation identified for storage. H<sub>2</sub> could theoretically be stored in three main geological structures (see Section 2.2): man-made salt domes; deep aquifers; and depleted oil and gas reservoirs. **But only salt caverns are known and proved as a safe storage solution** because: they are extremely gas-tight, which makes them an excellent means of storing fugacious H<sub>2</sub> (theoretical leakage rate of 0.01% a year); and crystalline salt is inert with H<sub>2</sub>. Although research continues to improve understanding of the impact of stress and operating pressure on the permeability of rock salt caverns, no significant safety risks have yet become apparent.

Unfortunately, salt formations are not always in areas where electricity-storage facilities are needed. To overcome this limitation, projects such as HyUnder and H<sub>2</sub>STORE are assessing the feasibility of using depleted hydrocarbon reservoirs and deep aquifers as storage sites. Geological mapping technology is improving understanding of the reactions and leaks that may occur.

**Figure 265: Anatomy of a salt dome<sup>2</sup>**

The size of a salt cavern is largely customizable, typically reaching 500 m in height and 50-100 m in diameter; and typically up to 700,000 m<sup>3</sup> in volume, with a maximum operating pressure of 20 megapascal [MPa].

A blow-out is the worst problem that can affect the facility. To prevent significant damage to the cavern head, safety shut-off valves – which close automatically if there is a risk of a blow-out – are installed around 50 m below the surface.

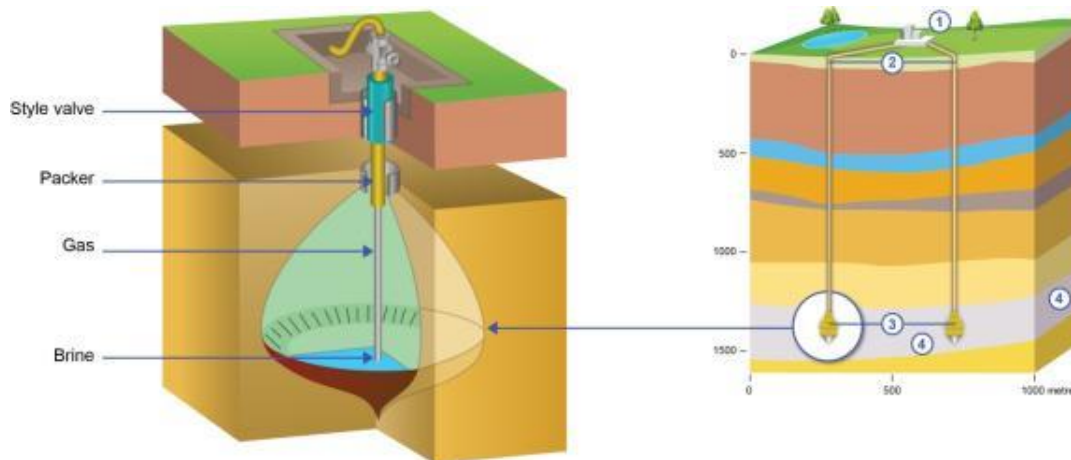

The risk of explosion is very low, however, because operating cavern pressure is always below the pressure of the encompassing formation. Furthermore, the caverns are deep underground (500-2,000 m) and the walls are extremely thick (10-100 m), providing a natural barrier to the oxygen necessary for combustion, as well as to any potential man-made damage (fire, or sabotage for example).

Compared with depleted oil and gas reservoirs, and deep aquifers, salt deposits allow higher injection and withdrawal rates, and require a lower volume of cushion gas.

1. Embrittlement of steel may pose problems to operational equipment (see Section 2.4).  
Source: Lord (2009); Crotagino et al. (2010); Image courtesy of: <sup>2</sup>Intragaz.

# Aquifers and depleted oil and gas reservoirs present some unresolved issues for H<sub>2</sub> storage

Although depleted oil and gas fields have long been used to store natural gas, and procedures are established to assess an aquifer's suitability for storage, H<sub>2</sub>'s highly reactive and diffusive properties raise significant challenges. Projects such as Hychico, in the Argentinian province of Chubut, and H<sub>2</sub>STORE in Germany and France, are testing for leaks and reactivity with the host rock by injecting H<sub>2</sub> into depleted gas fields.

So far, bacterial reactions have been observed in both aquifers and depleted oil and gas fields (figure 266), and other chemical interactions with H<sub>2</sub> may yet be discovered. Furthermore, there is concern that depleted hydrocarbons fields will initially produce severe contamination of the H<sub>2</sub>, from residual chemical elements that could give rise to impurities or further reactions. The risks of potential reactions are not well known, but the processes would result in the depletion of hydrogen. Methanogenic activity has been shown to reduce gas volume. If this persists until the formation pressure drops below the caprock threshold, leakage could occur.

The mobility of H<sub>2</sub> is twice that of natural gas, so the potential for leaks is higher. Concerns lie mainly with aquifer storage, because H<sub>2</sub> may penetrate surrounding water layers, or strata, which may present insufficient impermeability. Moreover, concerns regarding leaking in depleted oil and gas fields have been raised, and projects such as Hychico are setting up tests for potential leaks.

Further work is needed to determine possible risks before aquifers and depleted oil and gas fields can be judged safe for H<sub>2</sub> storage.

Figure 266: Heterogeneity of gases, resulting from bacterial methanogenesis<sup>1</sup>

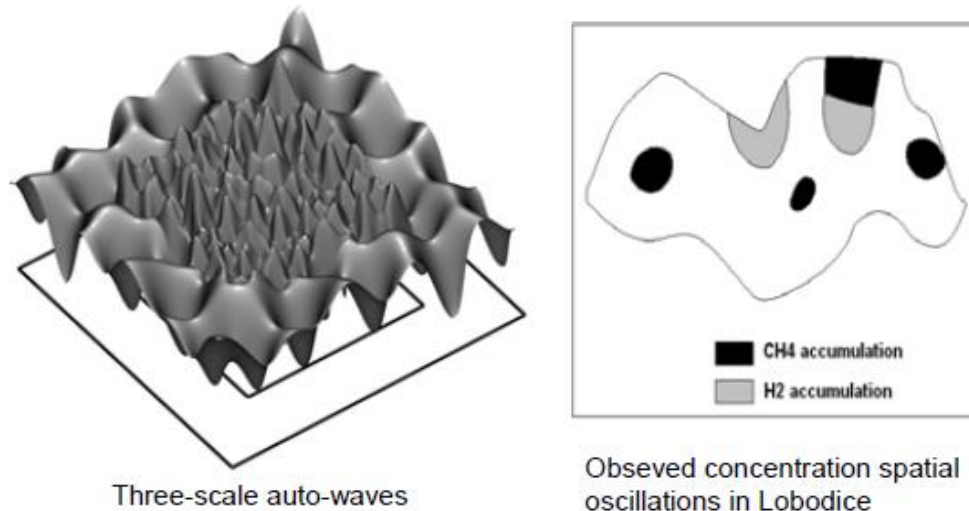

Methanogenic bacteria in water held within porous rocks feed off hydrogen (H<sub>2</sub>), carbon dioxide (CO<sub>2</sub>) and formate to produce methane (CH<sub>4</sub>) and water (H<sub>2</sub>O), effectively acting as a chemical reactor.

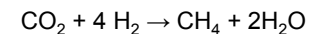

Mathematical modeling of the reactions shows stationary waves (left) that correspond to the alternations of zones rich in CH<sub>4</sub> or CO<sub>2</sub>. This result predicts the effect of a natural *in situ* separation of gases (right).

# Material damage and leaks are safety issues because of H<sub>2</sub>'s flammable, explosive nature

**Hydrogen is non-toxic and non-poisonous, does not create fumes and has low water solubility, so it will not contaminate groundwater. But like methane or gasoline vapor, hydrogen gas is flammable:** in the presence of an oxidizing agent and an inflammation source, it ignites. But its chemical properties make it different from other flammable gases, regarding: the conditions under which it explodes or ignites; and its behavior following ignition and the impact of ignition figure 267).

- **Conditions:** H<sub>2</sub> requires a very high concentration in air (up to 75%, almost 10 times more than gasoline) for ignition, but low energy input to ignite (figure 267). This means highly concentrated H<sub>2</sub> (clouds created by a leak in a confined space) could ignite with 10-times less energy (a spark, flame or blast wave) than methane. Finally, unlike most gases, which generally cool when they expand, hydrogen compressed at ambient temperature heats up when it expands to atmospheric pressure (Joule-Thomson Effect). On its own, this is unlikely to lead to spontaneous ignition, but has to be borne in mind due to its possible combination with other effects;
- **Behavior and impact:** in gaseous form, H<sub>2</sub> is very light and diffuses more rapidly than any other element. This reduces the risk of an explosion in open-air conditions, where H<sub>2</sub> rises and dilutes quickly into a non-flammable concentration. In confined spaces, however, it may create a concentration at the top of an installation, increasing explosion risk. A hydrogen flame is barely visible in daylight, because no CO<sub>2</sub> is released during combustion, necessitating fire-detection sensors; but the flame emits less heat radiation than that of hydrocarbons, limiting the risk of secondary fires.

**To summarize, all fuels can be hazardous and hydrogen is neither an exception, nor intrinsically more dangerous.** The risks are proportional to the safe management of its handling environment.

**Figure 267: Selective physical properties and risks in air of hydrogen, methane and gasoline**

Properties in air	Hydrogen	Gasoline vapor	Methane
<b>Flammability limits<sup>1</sup></b>	4 - 75%	1 - 7.8%	5.3 - 15%
<b>Ignition energy (mJ)<sup>2</sup></b>	0.02	0.24	0.29
<b>Explosion limits<sup>3</sup></b>	18 - 59%	1.1 - 3.3%	6.3 - 13.5%
<b>Flame temperature (°C)</b>	2'045	2'197	1'875

**H<sub>2</sub> is flammable over a wide range of concentrations and requires very low energy to ignite. But this energy requirement varies, depending on concentration: under 10%, ignition requires more energy, making it harder to ignite. Inversely, high concentrations, tending towards the stoichiometric<sup>4</sup> mixture, require increasingly low ignition energy.**

**Auto-ignition is unusual in vessels containing pure H<sub>2</sub>. Hydrogen explosions are yet more severe than those of other fuels (although explosions of hydrocarbon fuels carry more energy).**

**A hydrogen flame is as hot as a hydrocarbon flame, but emits less heat radiation, limiting the risk of secondary fires and reducing danger for the public and rescue workers. Hydrogen fires are vertical and localized, and the by-products of combustion are non-toxic.**

<sup>1</sup>% of H<sub>2</sub> required in a mixture for it to ignite. Below 4.1%, or above 75% concentration it cannot ignite. <sup>2</sup>Energy required to ignite a mixture of H<sub>2</sub>. <sup>3</sup>% of H<sub>2</sub> required in a mixture for it to explode. <sup>4</sup>Optimum % of H<sub>2</sub> required in a mixture for it to ignite (29%, 2% and 9%, for hydrogen, gasoline and natural gas respectively).

Source: Health and Safety Laboratory (2008); Bennaceur et al. (2005); Ricci (2005); The Fuel cell and Hydrogen energy association.

# Because H<sub>2</sub> leaks are difficult to detect, the use of sensors is crucial in preventing incidents. The limitations of existing detection technologies could delay deployment of hydrogen infrastructure

H<sub>2</sub> leaks are difficult to detect because the gas is colorless and odorless, and its flames are nearly invisible. Sensors are crucial to detect leaks, but H<sub>2</sub> molecules are so light that once they escape their container, they disperse immediately. To prepare for all potential leaks, sensors can be placed at an array of locations, based on modeled gas-cloud dispersion, to ensure the gas is detected quickly.

Although gas chromatography and mass spectrometry techniques are widely used for H<sub>2</sub> detection in laboratories, these methods are very bulky and expensive, making them impractical on an industrial scale. Commercial sensors can provide repeatable and accurate results (figure 268 and 269); but, often, these sensors are not ideally suited to H<sub>2</sub> and have a history of faulty signals, both negative and positive. Furthermore, they tend to be application-specific and have a short lifespan. Research is continuing and sensor technology is constantly improving. Testing, such as that of the NREL H<sub>2</sub>-safety sensor-test facility, strives to ensure that performance specifications are met.

Non-sensor safety measures include spark plugs. Placed in leak-prone areas, they ignite leaking gas to prevent build-up, which may otherwise lead to an explosion. Although sensors are important safety measures, they are not a replacement for standards of good practice.

**Figure 268: Hydrogen sensors and their properties**

Sensor types	Notable properties
Electrochemical; electrochemical reaction with H <sub>2</sub> produces an electrical signal proportional to the gas concentration	Repeatable over a broad range; Selectivity issues; Response time limitations; Short life; and Environmentally affected
Metal oxide; H <sub>2</sub> diffuses into the porous structure and reacts with the sensor to lower the surface concentration of oxygen, decreasing resistance	Selectivity issues; Environmentally affected; and High power requirements
Pellistor; coated surface catalyzes a surface combustion when exposed to H <sub>2</sub> , creating a temperature change that affects the sensor's conductivity	Selectivity issues; High power requirements; and Short life
Thermal conductivity - see pellistor	Selectivity issues; Good response time; and Sensitive to environmental drift
Palladium; conduction varies with H <sub>2</sub> concentration	Good selectivity; and Response-time limitations
Optical devices; optical properties of sensor platforms change when exposed to H <sub>2</sub> .	Good selectivity; and Poor repeatability and response time

**Figure 269: Example of a hydrogen fiber-optic sensor<sup>1</sup> (left), and colorimetric indicator (right), showing black exposed coating**

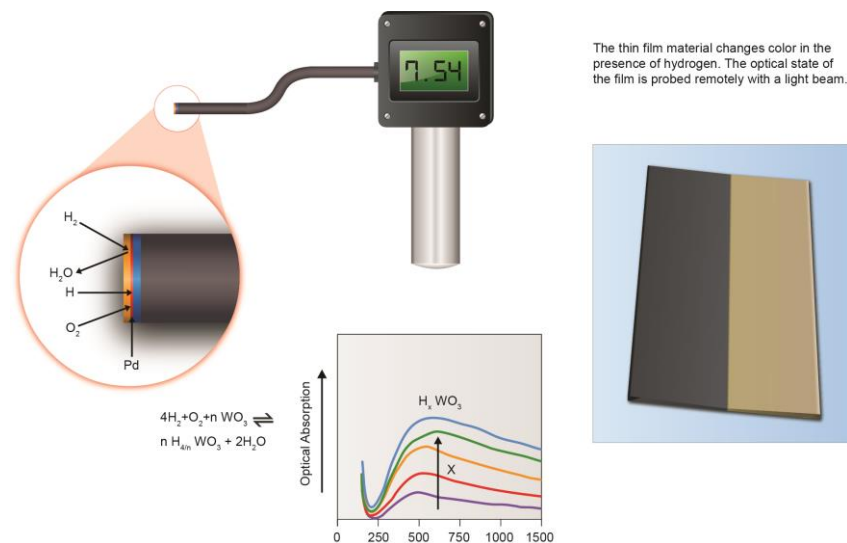

# Safety regulation, codes and standards for H<sub>2</sub> applications are being developed

The industrial use of H<sub>2</sub> is well established as a chemical feedstock, where it is handled by trained personnel. But its large-scale, commercial use as an energy carrier is undeveloped and will raise safety issues requiring new regulations, codes and standards [RCS] (figure 270). Partnerships such as Advancing the Transition to Hydrogen, collaborate with governments and hydrogen associations, such as the European Hydrogen Association, to establish consensus on RCS and facilitate transition to new systems. But international competitiveness and licensing issues make this work challenging.

Approaches to H<sub>2</sub> safety and RCS are based on existing practices. But the immaturity of the sector means there is a limited amount of data concerning the safety of systems, which inhibits policy development. Incident databases (such as HySafe and H<sub>2</sub> Incidents) gather experience from research and industrial trials. Also, various organizations and professionals are collaborating to produce handbooks, codes and standards to prevent mistakes from being repeated. And websites such as the ANSI Hydrogen Codes and Standards Portal gather codes and standards in one readily available, accessible place.

While some codes and standards for H<sub>2</sub> systems already exist, they do not fully address the growing range of systems available, which results in varying safety levels according to the field of use, leading to inhomogeneous RCS. For example: while stringent protocols are observed concerning pure H<sub>2</sub> operations, in sectors where hydrogen usage is just one part of a larger operation, the specific safety issues of H<sub>2</sub> may not be accounted for (such as embrittlement).

Figure 270: European Union Initiative Group – RCS Action plan

## Objectives:

- Facilitate the creation and adoption of RCS in stationary, residential and transportation applications;
- Harmonize the technical requirements of regulations, international codes and standards; and
- Integrate codes and standards from R&D to commercialization

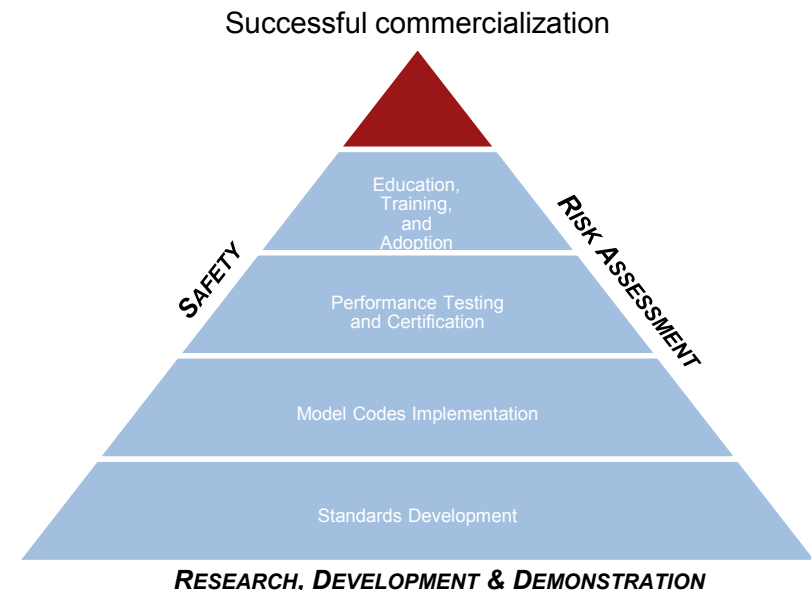

## Sources: section 4.2

Azkarate (2010), *“Materials and hydrogen”*

Bennaceur et al (2005), *“Hydrogen: a future energy carrier?”*, Kamel Bennaceur, Brian Clark, Franklin M. Orr Jr., Claude Roulet, Ellen Stout, Oilfield Review, vol. 17, pp 30-41

Brosha et al. (2012), *“FY 2010 annual progress report”*, Eric L. Brosha, Fernando H. Garzon, Robert S. Glass, US DoE Hydrogen Program, p1319

Buttner et al. (2012), *“An overview of hydrogen safety sensors and requirements”*, William J. Buttner, Matthew B. Prost, Robert Burgess, Carl Rivkin, International Journal of Hydrogen Energy, vol. 36, pp. 2462-2470

Crotogino et al. (2010), *“Large-scale hydrogen underground storage for securing future energy supplies”*, Fritz Crotogino, Sabine Donade, Ulrich Bunger, Hubert Landinger, Proceedings of the 18<sup>th</sup> World Hydrogen Energy Conference [WHEC] 2010

Energy Efficiency and Renewable Energy – EERE (2007), *“Fuel cell technologies office multi-year research, development and demonstration plan”*, The Fuel Cell Technologies Office

E.ON (2013), *“H<sub>2</sub> in the economy - The strongest link in the energy chain?”*, European Commission Workshop Proceedings, [http://ec.europa.eu/energy/technology/events/20130426\\_h2\\_in\\_the\\_economy\\_en.html](http://ec.europa.eu/energy/technology/events/20130426_h2_in_the_economy_en.html)

European Hydrogen & Fuel Cell Technology Platform (2005), *“Current status & action plan for implementing hydrogen regulations, codes & standards in the EU”*

Health and Safety Laboratory (2008), *“Spontaneous ignition of hydrogen – Literature Review”*

Herring (2010), *“Hydrogen embrittlement”*, Daniel H. Herring

Institut Franais du Ptrole Energies Nouvelles – IFP EN (2012), *“L’hydrogne, carburant de l’aprs-ptrole?”*

Intragaz, [http://www.intragaz.com/en/images/image\\_1-1-2-3\\_full.jpg](http://www.intragaz.com/en/images/image_1-1-2-3_full.jpg)

Kane (2008), *“Permeability, solubility, and Interaction of hydrogen in polymers- an assessment of materials for hydrogen transport”*, Marie Kane

Lord (2009), *“Overview of geologic storage of natural gas with an emphasis on assessing the feasibility of storing hydrogen”*, Anna S. Lord, Peter H. Kobos, Geoffrey T. Klise, David J. Borns, Sandia National Laboratories

Louthan (2008), *“Hydrogen embrittlement of metals: a primer for the failure analyst”*, MacIntyre R. Louthan

Melaina et al. (2013), *“Blending hydrogen into natural gas pipeline networks: A review of key issues”*, Marc Melaina, Olga Antonia, Michael Penev, National Renewable Energy Laboratory [NREL]

Mostert et al (2005), *“Low-temperature hydrogen damage assessment in the gas and refining industries”*, Roelf Mostertn, William R Sharp

NaturalHy (2004), *“Preparing for the hydrogen economy by using the existing natural gas system as a catalyst”*

Panfilov (2010), *“Underground storage of hydrogen: in situ self-organisation and methane generation”*, Mikhail Panfilov

Ricci (2005), *“Experts’ assessments and representations of risks associated with hydrogen”*, Miriam Ricci, UK Sustainable Hydrogen Energy Consortium.

Roads2HyCom (2008), *“Large hydrogen underground storage”*

Srensen (2008), *“Underground hydrogen storage in geological formation and comparison with other storage solutions”*, Bent Srensen, Roskilde University

The Fastener Engineer and Research Association (2006), *“Hydrogen embrittlement”*

The Fuel cell & Hydrogen Energy Association – FCHEA, *“Hydrogen safety factsheet”*; <http://www.fchea.org/index.php?id=50>

## 4.3 - Social acceptance



# The success of the deployment of an H<sub>2</sub> solution depends heavily on public support

**The use of hydrogen as an energy carrier is a relatively new concept and may be vulnerable to inaccurate public perception.**

**Social acceptance is crucial to the successful deployment of any new technology:** a survey by the US DoE shows that the public attach the utmost importance to safety. Hydrogen will not develop until it has been demonstrated to the public that the safety risks can be managed reliably and that hydrogen can deliver economic and environmental advantages (figure 271). To achieve this, the public's concerns must be acknowledged and analyzed, and information provided to improve their understanding – through projects such as AcceptH<sub>2</sub>. Addressing concerns inappropriately can lead to opposition and, potentially, the blocking of projects – for example, Vattenfall's abandoned carbon capture and storage facility, in Germany (figure 272).

**Although H<sub>2</sub> offers significant benefits over other fuels** (no pollution at the re-electrification site), **the public has expressed fear of hydrogen's explosive nature.** The Hindenburg disaster of 1937 and the association of the word hydrogen with the H bomb (which, incidentally, used the fusion of atomic cores and had nothing to do with hydrogen's chemical heating value), has negative connotations for hydrogen as a fuel, even today. In reality, it has a good safety record, with relatively few incidents.

Figure 271: Photograph of the Hindenburg disaster<sup>1</sup>



Figure 272: Why Vattenfall's CCS project was cancelled

With its development of post-combustion carbon-capture technologies, Vattenfall's Jämschwalde power plant, in Germany, was the EU's most advanced CCS demonstration plant. But progress ground to halt in December 2011. Strong public opposition undermined the political will needed to provide legislation for underground CO<sub>2</sub> storage in Germany.

The Eurobarometer 364 report indicated that people were worried about possible health effects of CO<sub>2</sub> leaks, but that they were not opposed to the concept of CO<sub>2</sub> storage as an environmental-protection strategy if proved safe. In the case of hydrogen, people are in favor of a technology that benefits the environment, but are concerned about safety issues.

# Social acceptance can be achieved with greater awareness of the risks and benefits of H<sub>2</sub> technologies

**Stakeholders in the H<sub>2</sub>-storage business must address non-technical barriers to acceptance.** The involvement of all affected parties early in the technology-implementation stage will ensure their participation in decision-making (figure 273).

**This can be achieved through:**

- **Education:** outreach programs to educate the public, project developers and other interested parties (education and training programs), increase safety awareness and support. Trust in hydrogen technologies can be built by demonstrating the safety not only of large demonstration projects, such as HyFleet CUTE [Clean Urban Transport for Europe], but also through awareness initiatives such as targeted workshops, presentations, web information and providing direct project support where effective;
- **Providing information on safety:** the industry has developed safety equipment to adapt to hydrogen's properties and behavior, which differ from conventional fuels. Leak-detection technology can play a big role in the battle for public acceptance and future implementation of hydrogen technology. If hydrogen is to be a mainstream energy carrier, the development and promulgation of codes and standards are essential (see Section 4.2). Regulators and safety officials must understand hydrogen technologies to facilitate permitting processes; emergency services must know how to handle incidents; and the public must be aware that there are reliable safety precautions in place; and
- **Emphasizing the environmental advantages of H<sub>2</sub> as a fuel:** the public must be informed of the environmental benefits of choosing hydrogen and fuel-cell technologies over traditional power systems.

**Figure 273: Steps to a socially accepted technology system**



**Figure 274: Advertising a hydrogen bus<sup>1</sup>**



## Sources: section 4.3

Buhr (2010), *“Public awareness and acceptance of CCS”*, Katarina Buhr, Center for Climate Science and Policy Research

CCS Network (2012), *“Lessons learned from the Jämschwalde project”*, The European CCS demonstration project network

European Commission - Directorate-General for Research (2006), *“Introducing hydrogen as an energy carrier: safety, regulatory and public acceptance issues”*

Stayapal (2013), *“Hydrogen & Fuel Cells - Program Overview”*, Sunita Satyapal, United States Department of Energy [US DoE]

van Bree et al. (2010), *“Social acceptance of hydrogen demonstration projects”*, Bas van Bree, Ingo Bunzeck, Energy research Centre of the Netherlands [ECN]

## Section 5 – Outlook



## The value of hydrogen-based solutions lies more in conversion than in storage Hydrogen can take full advantage of the green value of renewable power, while making use of existing infrastructure

The value of hydrogen-based storage solutions is usually assumed to lie in their unrivalled storage capabilities, which are derived from the hydrogen molecule's volumetric density<sup>1</sup> (or methane for power to gas concepts) and their ability to make use of existing gas infrastructure. **But, with a few exceptions** (e.g. off-grid, back-up applications that place a high value on the reliability of fuel-cell technology and islanded systems with a high penetration rate of variable renewables), **the value of hydrogen solutions lies predominantly in their ability to convert renewable power into green chemical carriers – hydrogen, methane, methanol and ammonia.**

In other words, the hydrogen's value lies mainly in its versatility. **More than just an energy carrier, hydrogen can act as a bridge between different branches of the energy-supply system** – optimizing the use of green energy generated from (excess) renewable power at the energy-system level while also utilizing chemicals infrastructure. In the context of the power system, hydrogen solutions will therefore – at least in the near term – be surplus- and transmission-driven, instead of deficit- and generation-driven.

**In many ways, the role of wind power + hydrogen or solar power + hydrogen can be compared to bioenergy** – the only renewable source of chemical energy. Similarly to bioenergy, hydrogen can be used in all forms of energy carrier (gaseous, liquid, thermal and electric). And, as with bioenergy, hydrogen can leverage infrastructure developed for hydrocarbons (pipelines, internal combustion engines, thermal power plants and storage facilities). As a result, like bioenergy, it is also an attractive intermediate solution as it can be blended with natural gas or gasoline. Indeed, the similarities between bioenergy and hydrogen make them complementary elements of power-to-gas systems (see Section 2.4), in which electrolytic hydrogen can increase biogas output by recycling excess carbon dioxide generated during the P2G process.

**Its ability to use heritage infrastructure gives hydrogen a powerful competitive edge.** As Lord John Browne says: “to give up or release yourself from your heritage is a really difficult thing to do [...] legacy – what happened in the past – anchors the future”<sup>2</sup>.

**Figure 275: Illustrative role of electrolytic hydrogen as a bridge between electron and molecular-based energy<sup>3</sup>**  
**W = H, Black = C, Red = Oxygen and Yellow for electrons**

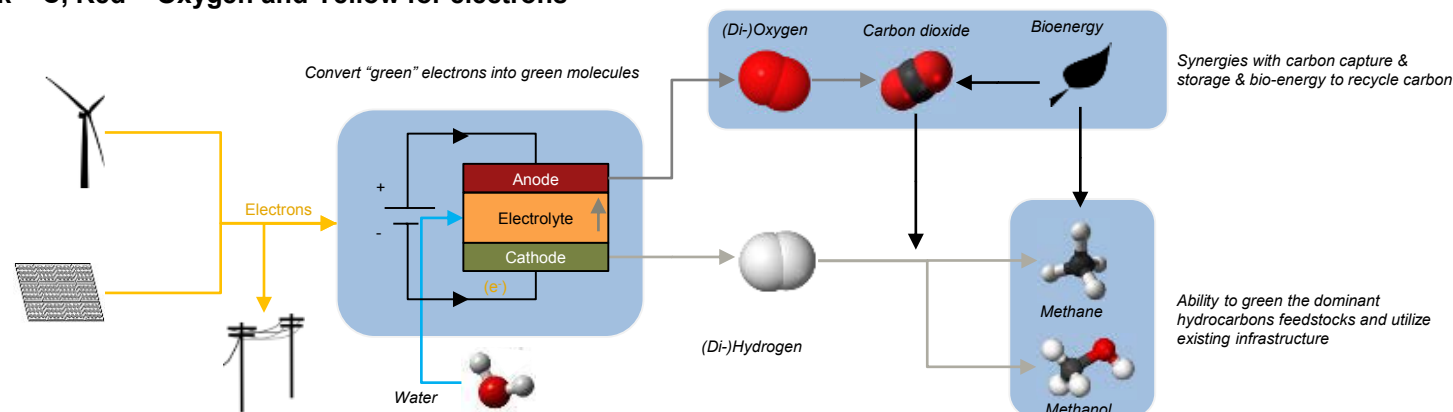

1. The volumetric energy density of hydrogen (kWh/l) is inferior to those of hydrocarbons, but superior to those of other bulk storage technologies, such as pumped hydro storage; 3the illustration is not comprehensive.

Source: 2Energy Perspectives 2012.

# There is no silver bullet for hydrogen-based storage solutions End-use requirements must be matched with the features of individual energy systems

There is no one-size-fits-all solution for hydrogen-based technologies. Hydrogen conversion enables the capture of the green value of variable renewables at the system level; its application, therefore, is, in essence, system-specific. For instance, hydrogen and gas blending may be worth considering in Argentina. The country has extensive wind resources, a highly-developed gas network and a high market penetration of natural gas vehicles, but domestic gas production is in decline. In California, which has an ambitious fuel-cell-vehicles program, direct use of hydrogen as a fuel may be more relevant. A simplified matrix is proposed below.

Figure 276: Simplified matrix of key energy-system factors, organized by hydrogen-solutions – illustrative only

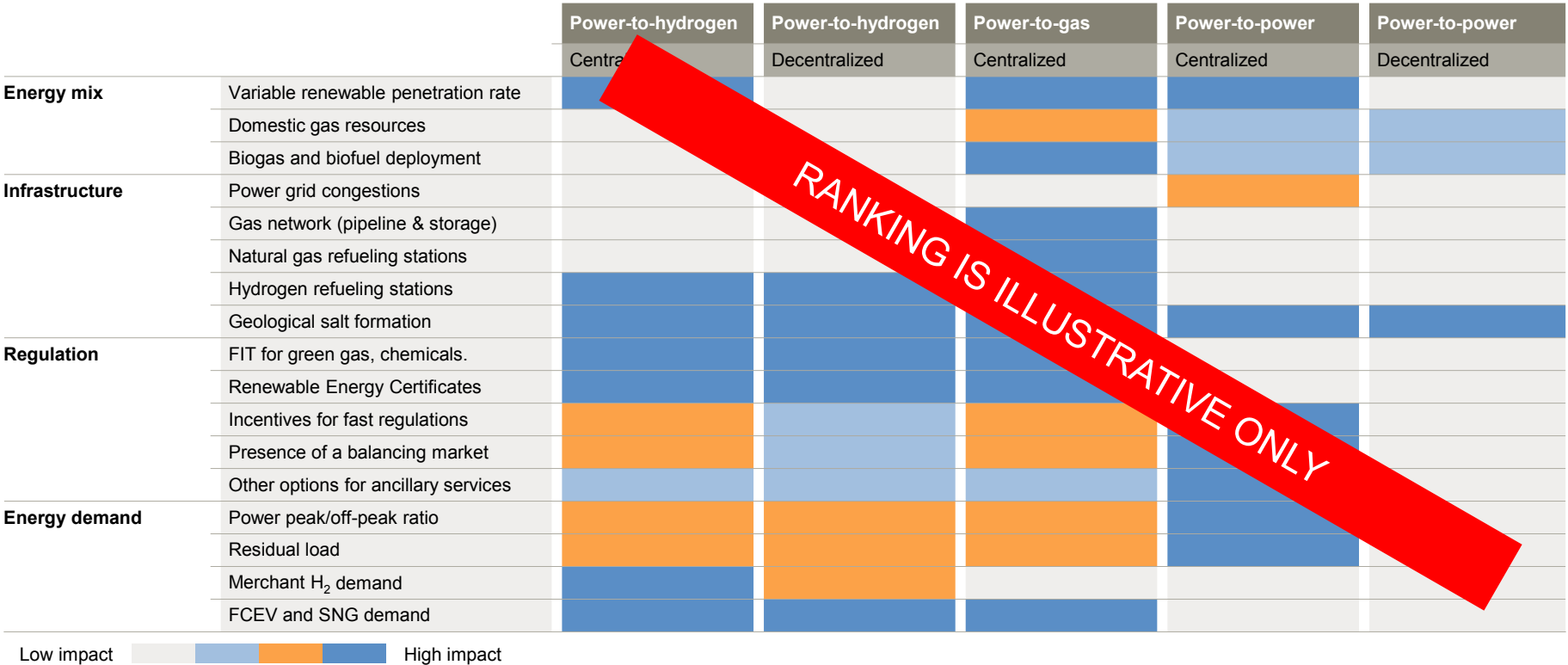

# The hydrogen landscape encompasses numerous stakeholders with conflicting interests

As hydrogen solutions act as bridges between energy sub-sectors, the hydrogen landscape brings together numerous stakeholders from across the energy world and allows new players to participate in renewable energy. These include large industrial gas merchants, small and medium-sized pure hydrogen companies, established power and gas utilities, automotive firms, oil and gas companies and equipment manufacturers. Differences in the way companies intend to utilize hydrogen and in their positioning within the electrical and chemicals industries have yielded a variety of hydrogen strategies.

The main division seems to be between (1) incumbent H<sub>2</sub> players (i.e. industrial gas merchants and car manufacturers) developing fuel-cell electric vehicles and (2) newcomers from the natural gas industry (e.g. gas network operators, gas suppliers, gas caverns constructors) favoring power-to-gas.

Traditional power and renewables companies tend to be more reluctant to embrace hydrogen technology because it competes with electricity as an energy carrier. They often react defensively to regulatory measures that may be introduced to foster the development of hydrogen systems<sup>1</sup>.

In addition, stakeholders in the oil and gas industry are starting to reassess their view of hydrogen. Hydrogen's place at the nexus of chemical energy and renewable power could, in many ways, complement their existing strategies for mobility (biofuels, fuel cell electric vehicles, gas transportation); they would also be able to harness their extensive experience of hydrogen use in downstream processes.

The hydrogen-equipment manufacturing sector is restructuring as this framework of interests evolves. New companies are becoming involved in the industry, mainly small innovative firms and a few multinationals<sup>2</sup>. These companies usually cover the full value chain, from electrolytic production to end-uses. In the field of electrolysis, the diversification of two alkaline-focused companies into PEM<sup>3</sup> electrolysis and power-to-gas technology has generated significant interest. However, so far, large manufacturers of alkaline electrolysis<sup>4</sup> have generally revealed little about their views of these new areas. It remains highly uncertain whether it will be possible to identify competitive electrolysis solutions and whether the learning curve will yield cost reductions. However, large investments by Siemens could change the perception of the attractiveness of PEM electrolysis, especially if other industrial firms with experience of mass-producing engineering products (such as those in automotive sector) follow suit and compete with established manufacturers.

Electrolysis <sup>5</sup>	Storage & transport <sup>5</sup>	Power-to-power <sup>5</sup>	Power-to-gas <sup>5</sup>	Power-to-mobility <sup>5</sup>
<ul style="list-style-type: none"> <li>Acta</li> <li>Areva (Helion)</li> <li>Axane</li> <li>Ceram Hyd</li> <li>CETH<sub>2</sub></li> <li>FuelCell Energy Solutions</li> <li>H<sub>2</sub>Nitidor</li> <li>Hydrogenics</li> <li>ITM Power</li> <li>Linde</li> <li>McPhy</li> <li>NEL Hydrogen</li> <li>Proton OnSite</li> <li>Siemens</li> <li>Sunfire</li> </ul>	<ul style="list-style-type: none"> <li>Air Liquide</li> <li>Air Products</li> <li>AzkoNobel</li> <li>Cella Energy</li> <li>Deep Underground</li> <li>Hychico</li> <li>Hydrexia</li> <li>IVG Caverns</li> <li>KBB Underground</li> <li>Linde</li> <li>MaHyTec</li> <li>McPhy</li> <li>Praxair</li> <li>Proton OnSite</li> <li>UGS</li> </ul>	<ul style="list-style-type: none"> <li>Air Liquide</li> <li>Air Products</li> <li>Areva</li> <li>Ballard</li> <li>Bosh</li> <li>Ceramic Fuel Cells</li> <li>FuelCellEnergy</li> <li>H2Nitidor</li> <li>Heliocentris</li> <li>Hydrogenics</li> <li>ITM Power</li> <li>Linde</li> <li>NEC</li> <li>Plug Power</li> <li>NEC</li> <li>Plug Power</li> <li>Praxair</li> <li>Proton OnSite</li> <li>Quantum Fuel Systems</li> <li>Serenergy</li> <li>SFC Energy</li> <li>Siemens</li> <li>Sunfire</li> <li>Teledyne Technologies</li> <li>Topsoe</li> <li>Viessmann</li> </ul>	<ul style="list-style-type: none"> <li>E.ON</li> <li>Electrochaea</li> <li>Energinet.dk</li> <li>Etogas</li> <li>Fluxys</li> <li>Gasunie</li> <li>GDF Suez</li> <li>GP Joule</li> <li>GrDF</li> <li>GRTgaz</li> <li>H2Nitidor</li> <li>Hydrogenics</li> <li>ITM Power</li> <li>IVG Caverns</li> <li>KBB Underground</li> <li>Krajete</li> <li>Linde</li> <li>Maersk Oil</li> <li>McPhy</li> <li>MicrobEnergy</li> <li>National Grid</li> <li>RWE</li> <li>Sunfire</li> <li>UGS</li> <li>Vaillant</li> <li>Viessmann</li> </ul>	<ul style="list-style-type: none"> <li>Air Liquide</li> <li>Air Products</li> <li>BMW</li> <li>Bosh</li> <li>BP</li> <li>Cella Energy</li> <li>Daimler</li> <li>Ford</li> <li>General Motors</li> <li>H2Nitidor</li> <li>Hitachi</li> <li>Hydrogenics</li> <li>Honda</li> <li>Hyundai</li> <li>ITM Power</li> <li>LG Chem</li> <li>Linde</li> <li>NEC</li> <li>OMV</li> <li>Plug Power</li> <li>Praxair</li> <li>Proton OnSite</li> <li>Quantum Fuel Systems</li> <li>Shell</li> <li>Siemens</li> <li>Symbio FCell</li> <li>Toshiba</li> <li>Total</li> <li>Toyota</li> </ul>

1. For example, rules that may oblige renewable-energy producers to convert excess energy into hydrogen, rather than curtailing production; 2including Areva and Siemens; 3PEM: proton exchange membrane; 4such as NEL Hydrogen, Teledyne Technologies and SFC Energy; 5Non exhaustive list.

Source: A.T. Kearney Energy Transition Institute analysis, based on interviews.

## In all cases, the deployment of hydrogen systems requires cost reductions and public support

Whatever the end-use and the energy system, hydrogen-based solutions development is subject to three pre-requisites: (1) a greater penetration of variable renewables in the power mix; (2) the reduction in the cost of electrolysis; and (3) strong support from public authorities in the near and medium terms.

Beyond these general conditions, forecasts for growth in the hydrogen sector are too speculative to be of practical use. They must be system specific. A tentative roadmap is proposed in figure 277 for Europe, based on interviews with various stakeholders. It highlights the bridging role that gas blending may play between nascent power-to-power markets and future markets using hydrogen for mobility, produced either by fuel cells or by greening gas (blended or synthetic).

Figure 277: Illustrative roadmap for hydrogen-based energy storage solutions in Europe

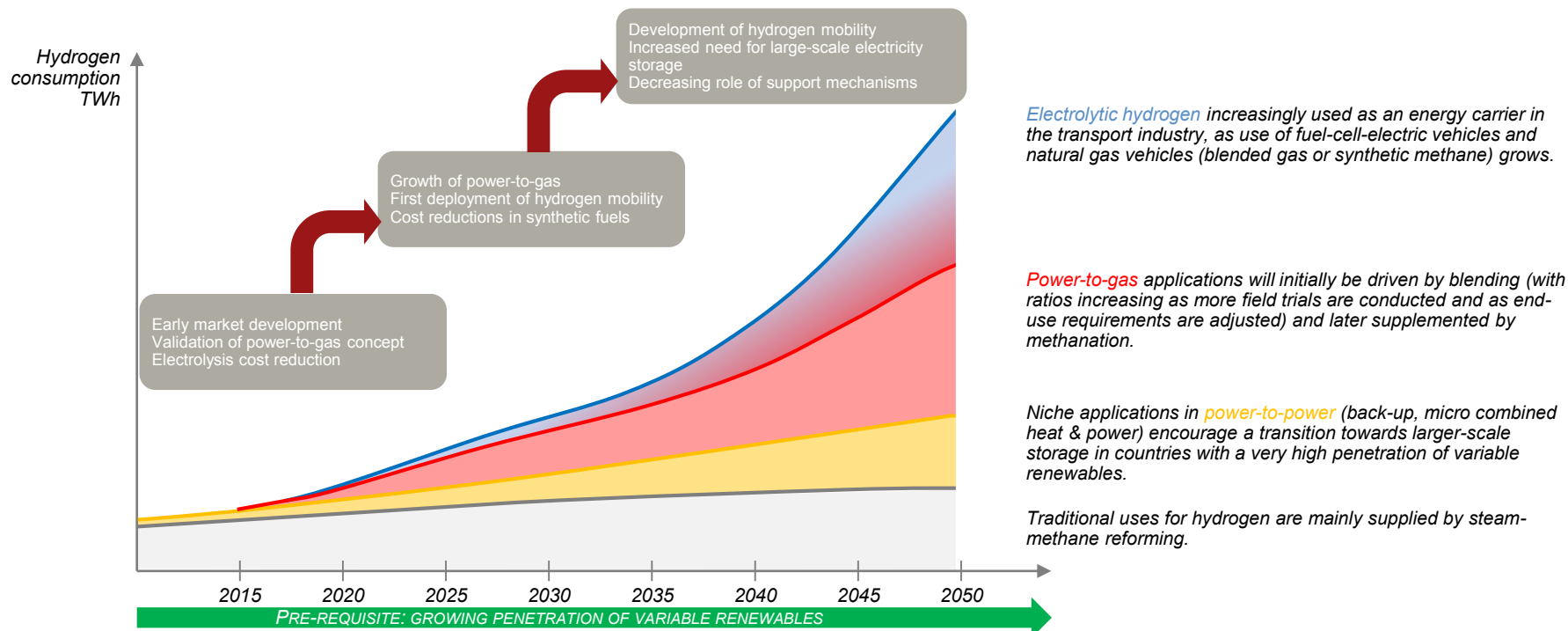

# Many individual, hydrogen-related technologies are technologically mature, but conversion processes between electricity, hydrogen and light synfuels are in the valley of death

The horizontal axis of (figure 278) ranks the main hydrogen-related technologies\* by technological maturity. The vertical axis ranks the effort needed to get individual technologies closer to maturity (in terms both of capital investment and risk). Technologies in the first three stages (R,D&D) are not yet proved, nor commercialized. Also, although risks are high, costs are relatively low because development is restricted to lab work. The most important stage is near the end of the demonstration stage (also called the valley of death), where technology is both expensive to demonstrate at full scale and its feasibility/profitability remain uncertain; this accounts for the curve's bell shape. Technologies in the Deployment and Mature stages are commercialized, and ranked according their remaining potential for optimization (the margin for improving techno-economic performance).

**Figure 278: Technological maturity curve of hydrogen-related technologies**

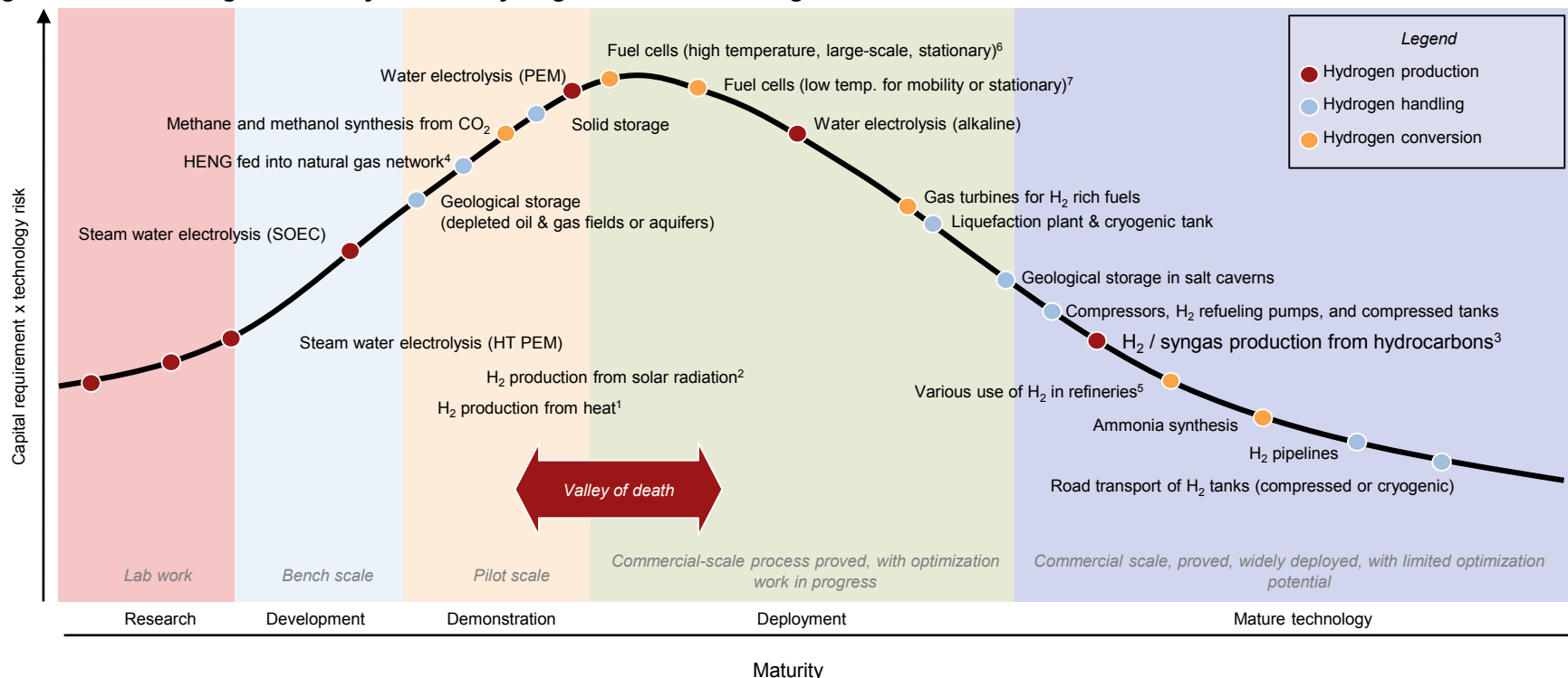

Note: \*Excluding nuclear-related technologies; 1Nuclear or solar thermochemical water splitting; 2Photolysis, photo-electrolysis or photo-biological water-splitting; 3By thermochemical processes, principally: methane reforming, the cracking of petroleum fractions, and coal or biomass gasification; 4HENG: Hydrogen-enriched natural gas; 5Includes the upgrading of heavy/sour oil and the synthesis of synfuels from syngas (methanol, DME, MtG etc); 6Includes SOFC, PAFC and MCFC; 7Includes PEMFC and AFC.

# Hydrogen-based energy-storage projects are still a long way from commercial deployment

Contrary to the maturity curve depicted in the previous slide, **figure 279** ranks integrated hydrogen-based projects (instead of individual technologies) by business maturity (as opposed to technological maturity). It illustrates how far projects are from commercial success at present<sup>1</sup>. Projects also follow a bell-shaped curve, reflecting the high cost and risks of turning concept plants into businesses.

**Most integrated projects using electrolytic hydrogen are in the early demonstration phase** and are entering the valley of death. Here, the lack of guaranteed revenues often means external funding is required to demonstrate that an individual technology can be efficiently integrated and utilized at a large scale. Some projects may be able to move out of the valley of death and find commercial applications. Their ability to derive value from the learning curve (improving competitiveness while still being rolled out) will improve their chances of eventually being widely deployed. Their utilization rate will also be essential in helping their business case.

**Figure 279: Commercial maturity curve of integrated hydrogen projects**

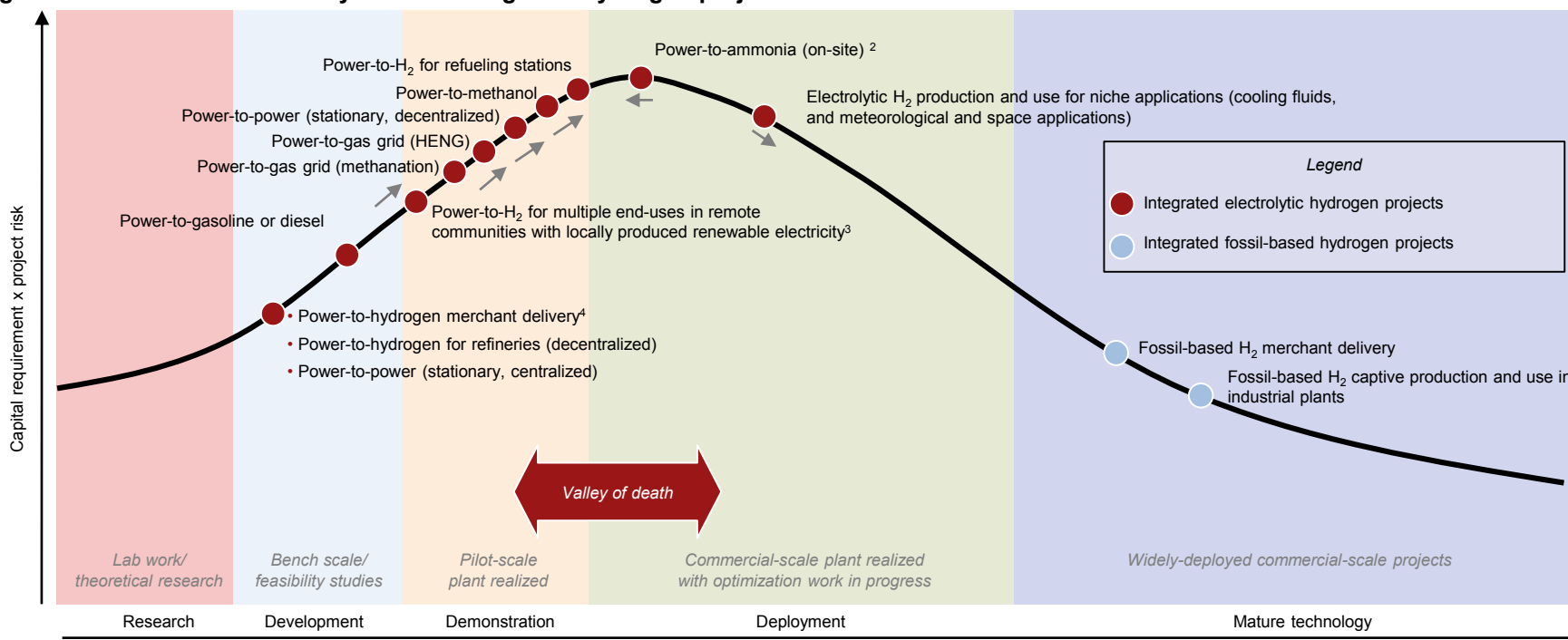

1. The ranking is an estimate, based on the number of plants installed and their total capacity; in the case of the R,D&D stage, it is based on the size of the largest demonstration project relative to that of a commercial-scale plant. The grey arrows illustrate the dynamics of these projects over time; <sup>2</sup>Only three plants are still in operation, and are being replaced by coal or methane-based hydrogen; <sup>3</sup>Niche applications require electrolytic hydrogen for its purity.

# The main priority for R,D&D is improving conversion technologies between electricity and hydrogen

**Electrolyzers and fuel cells [FCs] are reverse processes that share technological know-how and face similar hurdles. Yet, contrary to the approach adopted so far, efforts should focus on electrolyzers rather than FCs**, because they are the initial step common to all hydrogen-based energy-storage projects. There remains a critical need to develop flexible and pressurized (>30 bar) electrolyzers capable of withstanding variable load – features missing from first-generation alkaline electrolyzers. Secondly, R,D&D investments should focus on improving conversion between H<sub>2</sub> and syngas. Better economic models should be developed in parallel, taking into account the varied contributions hydrogen could make to future energy systems. R&D is no longer the bottleneck in the case of hydrogen mobility, where cost reductions are now expected from market development.

R,D&D axis	Objective	Means
Hydrogen/ electricity conversion	Realize cost reduction potential of proton exchange membranes [PEM] (of both electrolyzers and fuel cells)	<ul style="list-style-type: none"> <li>✓ Leaner batch process for mass manufacturing</li> <li>✓ Reduce or replace noble metal catalysts</li> <li>✓ Develop wider and thinner polymer membranes just as resistant to degradation</li> <li>✓ Develop MW-scale stack concepts</li> <li>✓ Recycle PEM electrolyzers and fuel cells to recover platinum</li> </ul>
	Overcome technological hurdles facing solid oxide technological hurdles	<ul style="list-style-type: none"> <li>✓ Reduce stack performance degradation by improving membrane electrode assembly lifetime</li> <li>✓ Reduce the rate of mechanical failures of the cell at manufacturing</li> </ul>
	Improve flexibility, operational pressure and O&M costs of alkaline electrolyzers	<ul style="list-style-type: none"> <li>✓ Test new cell designed to avoiding electrolyte circulation costs (ex: Gas diffusion electrode)</li> <li>✓ Develop materials resistant to higher temperatures</li> </ul>
Hydrogen/ syngas conversion	Evaluate the impact of H <sub>2</sub> blending	<ul style="list-style-type: none"> <li>✓ Carry out field tests of pipeline safety and integrity when transporting hydrogen-enriched natural gas</li> <li>✓ Model the H<sub>2</sub> concentration diffusion into the gas grid</li> <li>✓ Test and improve the performance of end-use applications under a range of H<sub>2</sub> concentrations</li> </ul>
	Demonstrate power-to-methane and power-to-methanol concepts	<ul style="list-style-type: none"> <li>✓ Demonstrate the operating stability and flexibility of an integrated plant at a large scale</li> <li>✓ Map potential CO<sub>2</sub> sources. Focus on electrolysis-assisted biofuels/biomethane plants</li> <li>✓ Explore the potential of bacteriological catalysis as an alternative to the thermochemical Sabatier Reaction</li> <li>✓ Develop direct methanol solid oxide electrolyzer cells</li> </ul>
Hydrogen handling	Pave the way for underground hydrogen storage	<ul style="list-style-type: none"> <li>✓ Map suitable geological sites, in particular salt formations suitable for mining caverns</li> <li>✓ Study contamination of H<sub>2</sub> of components (rocks, fluids, microorganisms) in aquifers or oil &amp; gas reservoirs</li> <li>✓ Test H<sub>2</sub> recovery rate related to pressure losses in aquifers or depleted oil &amp; gas reservoirs</li> </ul>
	Bring metal hydride (solid state) hydrogen storage to market	<ul style="list-style-type: none"> <li>✓ Reduce charging/discharging times, improve cycling lifetime</li> <li>✓ Reduce cost of heat-recovery system</li> </ul>
Economic models	Provide policymakers with clearer guidance	<ul style="list-style-type: none"> <li>✓ Improve system-wide cost/benefit analysis of electricity storage solutions (power-to-power)</li> <li>✓ Model the benefits of the versatility of electrolytic hydrogen end-use beyond re-electrification (power-to-anything)</li> </ul>

## Public and corporate funding are needed to help hydrogen solutions move from field demonstration to large-scale deployment and must focus more on electrolysis and power-to-synfuel

**Individual hydrogen-based technologies are now sufficiently proved to enable the establishment of large, integrated demonstration projects. These, however, are still largely locked in the investment valley-of-death, even though mid-scale demonstration projects exist in Europe, such as Enertrag Hybrid Power-Plants, in Germany, and the UK's planned Ecoland project.**

**The usual sources of financing are unlikely to be able to overcome barriers to financing for the time being:** venture capital and private-equity funding will not bear the risk of these projects, and banks are only granting loan against existing cash-flow. As a result, public and corporate funding remains essential.

**Public-private partnerships at the national or transnational level** – such as Europe's Fuel Cell and Hydrogen Joint Undertaking [FCH JU]<sup>1</sup> or the recently launched H<sub>2</sub>USA<sup>2</sup> venture – **have demonstrated their ability to fund the journey from research lab to large-scale deployment.** However, as a legacy of the push in the 2000s to introduce hydrogen as a fuel for mobility, most financing structures are driven by the demand side, especially fuel-cell-electric vehicles and residential combined heat and power [CHP] fuel cells. These partnerships may gain by investigating electrolysis and new end-uses for hydrogen, such as power-to-gas and power-to-liquids, while maintaining their traditional areas of focus – mobility and residential CHP.

**Figure 280: Examples of technology-push and market-pull policy instruments from IEA ETP 2012<sup>5</sup>**

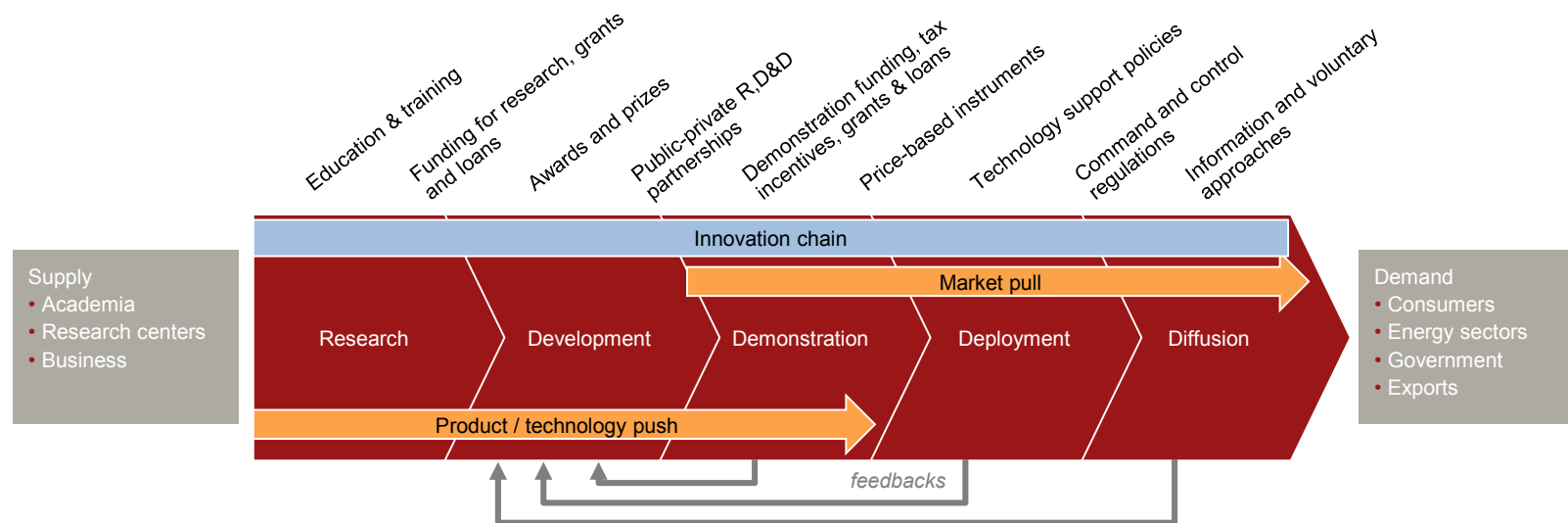

# Pull measures, including green value monetization and regulatory incentives, could assist a transition to self-sustaining commercial activity

In addition to R,D&D funding, public authorities have a wide variety of temporary incentives at their disposal that could transform hydrogen-based solutions into self-sustaining commercial activities, and compensate for their lower external costs<sup>1</sup>. The most common support mechanisms applicable to renewable electrolytic hydrogen are: (i) feed-in tariffs; (ii) grid-fee exemptions; (iii) tax exemptions; and (iv) quotas and mandatory targets.

The choice is primarily a political decision. However, as there is no one-size-fits-all solution, the choice of mechanism also depends on the particular features of a given system and its expected applications (e.g. grid exemptions are relevant in grid-connected power-to-gas projects but irrelevant in decentralized hydrogen production supplying a refueling station). The questions of who should be incentivized and, consequently, who should bear the cost must also eventually be answered. An important question concerning electrolytic hydrogen is whether variable renewable power producers should be obliged to avoid wasting temporary excesses energy or receive bonus payments for avoiding wastage. At present, they are usually paid to shut down<sup>2</sup>.

## Feed-in-tariffs



Feed-in-tariffs are the first tool in the box and can be used directly to monetize the green value of renewable electrolytic hydrogen and its derivatives (e.g. blended gas, synthetic methane). Several tariffs are already in place for renewables and could be extended to cover hydrogen and synthetic fuels (e.g. €45 to €125 /MWh in France for biogas, depending on plant size). In Germany, meanwhile, the Energy Economy Act [EnWG] has expanded the definition of biogas and determined that at least 80% of the power used in the electrolysis stage must come from renewable sources<sup>3</sup>.

## Exemptions: grid & connection fees



The second method involves reducing grid and connection fees. Grid-connected hydrogen producers are theoretically paying twice as much as they should for power that would have otherwise been curtailed: to withdraw power and to inject the final product (power in case of re-electrification, gas for power-to-gas). Grid fees could be reduced or even removed for plants erected upstream of congestion points or close to natural gas grids. In the case of power-to-gas, grid-connection costs may also be reduced and shared with gas-grid operators. In Germany, the Gas Grid Access Ordinance requires the grid operator to bear 75% of connection costs<sup>3</sup>.

## Exemptions: tax



The third approach is tax exemption and is commonly used in the mobility sector, where hydrogen and renewable fuels or vehicles tend to be fully exempted from the tax burden. This makes them competitive with gasoline prices (e.g. Germany Renewable Energy Act [EEG]<sup>3</sup>) and conventional internal combustion engine vehicles. However, large-scale tax exemptions are likely to be problematic from a state budget perspective: fuel taxes tend to generate large tax revenues in most Western countries.

## Quotas & mandatory targets



Finally, quotas and mandatory targets are the usual alternative (or complement) to subsidies and exemptions. The key for hydrogen-based solution is to be eligible to take advantages of the mechanisms that are put in place. For example, synthetic fuels and blended gas based on renewable hydrogen should be allowed to contribute to the EU target of powering 10% of transport with renewable energy by 2020. Sector-specific targets may also be investigated (e.g. a share of green flexibility resources for balancing).

1. As mentioned by the Strategic Energy Technology Plan - EC (2011), fuel cell & hydrogen must compete with incumbent technologies that incur a higher external cost (e.g. pollution) not included in their overall costing. In other words, their societal benefits are not taken into account; 2According to The Telegraph (2013), £15 million have been paid on April 29th 2013 to Scottish wind farm; 3Gottwald (2012).

## For hydrogen-based solutions to be successful, renewable-energy certificates must be integrated across all energy sectors

**In parallel with feed-in tariffs and tax exemptions – monetary expressions of political support – renewable-energy certificates are needed for traceability and proof of origination.** There is no sense in promoting power-to-gas or power-to-chemical if no attention is paid to the primary energy source and the carbon footprint.

**In fact, unlike feed-in tariffs, which follow regulatory mechanisms, certificates are market-oriented devices.** They can be sold to customers or operators willing to pay a premium for a green product. Certificates could become the currency of green-energy markets, creating new trading floors on gas and power exchanges (e.g. a Green-EEX<sup>1</sup>).

**However, schemes of this nature would have to be devised at the system level in order to prevent sectorial regulations from obstructing cross-sector synergies<sup>2</sup>.** Since the benefit of renewable electrolytic hydrogen lies in its ability to decompartmentalize the energy system<sup>2</sup>, an integrated structure for all renewables certificates is required, irrespective of their carrier (figure 281). This means the process of converting a certificate from one energy carrier to another must be clearly defined and agreed by all participants.

As advocated by Energinet.dk, the Danish power and gas system operator, the ideal way forward would be “an integrated energy market for natural and renewable gas on top of a parallel certificate market to trade the green value of electricity, gas, hydrogen and other fuels”<sup>2</sup>. Without such a market design, system integration is likely to remain wishful thinking.

**Figure 281: Simplified scheme for renewable-certificate exchange within an integrated energy market<sup>3</sup>**

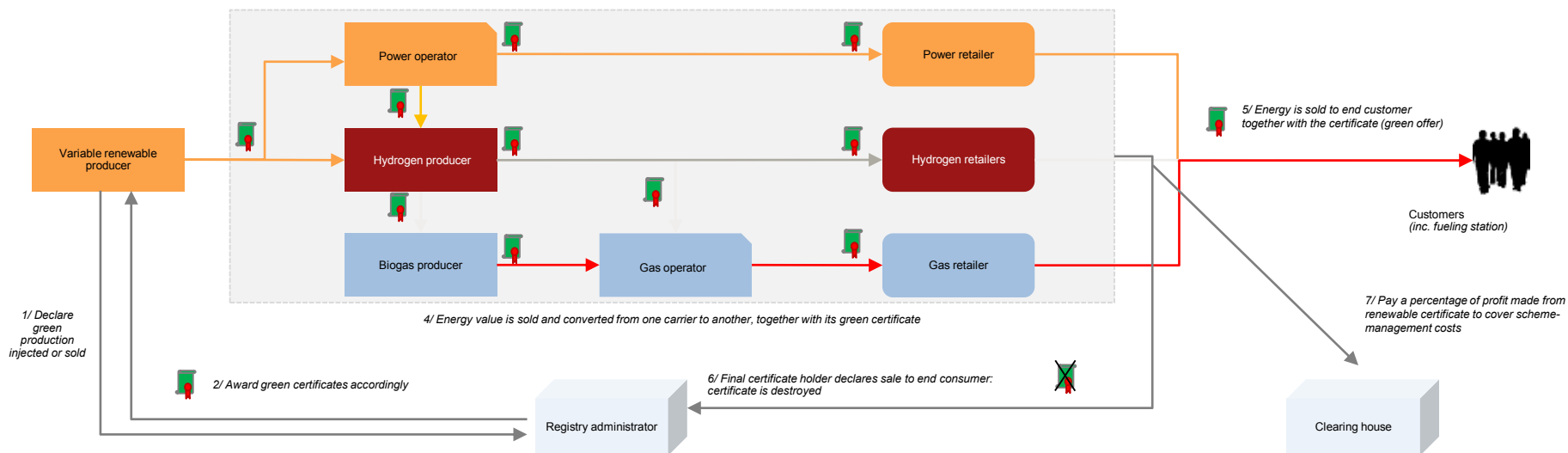

# Regulations, codes and standards must be harmonized and adapted to enable growth in the hydrogen industry

**Public support in the form of financing structures and suitable regulation is also essential to encourage the deployment of hydrogen solutions in the near term.** It is just as important to address public acceptance and perception.

## Regulatory framework for natural gas blending



It is necessary to introduce regulations governing: blending ratios (varying according to injection points, end-uses and pipeline materials); operating ranges (variation change and variation speed); and operating rules (pressure of injection, flow rate). Due to the importance assigned to the quality of gas and inter-operability, some international cooperation is necessary, although regulation will be largely system specific and based on local conditions. Several projects and initiatives have been launched in recent years (NaturalHy, in the late 2000s, as well as projects undertaken by the European Gas Research Group [GERG] and, more recently in the US, by the Gas Technology Institute<sup>1</sup>). But more field trials are needed to create a regulatory framework. Regulation is urgently required for gas blending to serve as a solution in the short-to-medium term.

## Participation of storage in ancillary services



The conditions under which energy-storage solutions participate in ancillary services must also be reviewed and adjusted, as energy storage is a new infrastructure element. In addition to grid-fee exemptions, the lower-access threshold – *i.e.* the minimum power capacity needed for a market participant to be eligible to balancing market – must be reduced to enable storage to play a role<sup>2</sup>. The conditions regarding conversion and re-conversion for hydrogen-solutions to be considered as storage should also be clarified<sup>3</sup>.

## Safety protocols



Regulations, codes and standards [RCS] are essential to ensure the safe handling of hydrogen (see Section 4.2). There is, at present, no uniform set of standards; there are very stringent rules for small-scale merchant hydrogen consumers, but few codes have been specifically created for large petrochemicals facilities, which are experienced at handling flammable gases<sup>4</sup>. A balance must be found if hydrogen is to become widely used. RCS are particularly needed in the case of power-to-gas and power-to-mobility applications, and need to be harmonized across countries (e.g. International Standard Organization [ISO] standards).

## Social acceptance & education



The engagement of various groups of stakeholders is also fundamental to the success of commercial hydrogen projects (see Section 4.3 on Public Acceptance). For this reason, public consultation and effective communication with local communities are essential. A robust academic curriculum to train and educate hydrogen professionals is also an important step in deploying hydrogen commercially. The US's DoE, for instance, has developed 25 university courses and curriculum modules at five universities, and disseminated hydrogen and fuel-cell course materials to over 8,000 teachers. It has also launched a public information program, "Increase Your H2IQ"<sup>5</sup>.

## Sources: section 5

Air Liquide (2012), “*Financing hydrogen projects – business cases and political support?*”, Proceeding of the IPHE Conference in November 16<sup>th</sup> Sevilla Workshop

Lord John Browne of Madingley (2012), “*The challenge of transition*”, An interview with Lord John Browne of Madingley by Antoine Rostand,  
[http://www.A.T.KearneyEnergyTransitionInstitute.slb.com/Our\\_Ideas/Energy\\_Perspectives/Winter12\\_Content/Winter12\\_Interview\\_John.aspx](http://www.A.T.KearneyEnergyTransitionInstitute.slb.com/Our_Ideas/Energy_Perspectives/Winter12_Content/Winter12_Interview_John.aspx)

Energinet.dk (2013), “*Perspectives on hydrogen from an integrated energy system perspective*”, Proceeding of the European Commission workshop in April 26<sup>th</sup> Brussels

European Commission (2011), “*Strategic Energy Technology Plan (SET-Plan)*”, Proceeding of the European Commission workshop in April 26<sup>th</sup> Brussels

European Gas Research Group (GERG) – (2013) a, “*Adapting the Natural Gas Network for Hydrogen*”, Proceeding of the European Commission workshop in April 26<sup>th</sup> Brussels

Dr. Thorsten Gottwald (2012), “*Power-to-gas*”, Proceeding of the IRES Conference in November 15<sup>th</sup> Berlin

Hydrogenics (2013) a, “*H<sub>2</sub> in the economy - from research to business cases*”, Proceeding of the European Commission workshop in April 26<sup>th</sup> Brussels

Institut Français du Pétrole Energies Nouvelles – IFP EN (2012), “*Hydrogène, carburant de l’après-pétrole?*”

National Renewable Energy Laboratory – NREL (2013), “*Blending hydrogen into natural gas pipeline networks: A review of key issues*”

The Telegraph (2013), “*Scottish wind farms paid £1 million to shut down one day*”, 5<sup>th</sup> May 2013,  
<http://www.telegraph.co.uk/news/uknews/scotland/10038598/Scottish-wind-farms-paid-1-million-to-shut-down-one-day.html?fb>

United States Department of Energy (2011), “*The department of energy hydrogen and fuel cells program plan*”

# Appendix



# Glossary

**Adsorption** - The adhesion of a substance's molecules to the surface of the solids, or liquids with which they are in contact.

**Alkali** - A chemical base that dissolves in water.

**Anode** - The electrode at which oxidation takes place.

**API gravity** - The scale developed by the American Petroleum Institute to measure the relative density of petroleum liquids, in degrees.

**Battery** - An energy-storage device that produces electricity by means of chemical action.

**BoP** - Balance of plant is the auxiliary equipment required to ensure a system operates reliably.

**British thermal unit (Btu)** - The quantity of heat required to raise 1 pound of water by 1°F.

**Catalyst** - A chemical substance that increases the rate of a reaction without being consumed.

**Cathode** - The electrode at which reduction occurs.

**Combustion** - The fire produced by a combination of fuel, heat and oxygen.

**Distributed generation** - The production of electrical power close to the end user.

**Electrode** - A conductor through which electrons enter or leave an electrolyte.

**Electrolysis** - A process that uses electricity, passing through a medium, to cause a reaction that breaks chemical bonds.

**Electrolyte** - A substance that conducts charged ions from one electrode to another.

**Endothermic** - A chemical reaction that absorbs, or requires energy, usually heat (opposite of exothermic).

**Greenhouse effect** - The warming of the Earth's atmosphere resulting from the release of greenhouse gases. These gases allow solar radiation (visible, ultraviolet) to reach the Earth's atmosphere, but prevent emitted infrared radiation from passing back out of the Earth's atmosphere.

**Higher heating value (HHV)** - The value of the heat resulting from a fuel's combustion, measured by reducing all of the products of combustion back to their original temperature and condensing all water vapor formed by combustion. This value takes into account the heat generated by water vaporization.

**Hydrogen economy** - A scenario under which the world uses hydrogen as the primary energy carrier in place of fossil fuels.

**Load following** - A load-following device generates variable amounts of electrical power depending on the requirements of the devices it is powering.

**Lower heating value (LHV)** - The value of the heat resulting from a fuel's combustion, measured by allowing all products of combustion to remain in the gaseous state. This measurement does not account for the heat required for water vaporization.

**Nafion®** - Sulfonic acid in a solid polymer form. Usually the electrolyte of PEM fuel cells.

**Natural gas** - Mixtures of hydrocarbon gases, consisting principally of methane.

**Oxidant** - A chemical that consumes electrons in an electrochemical reaction.

**Polymer** - Compound composed of repeated links of simple molecules.

**Renewable energy** - A form of energy that is never exhausted because it is renewed by nature within short time scales.

**Wt.%** - Abbreviation for weight percent; denotes the amount of hydrogen stored on a weight basis.

## Accronyms – (1/2)

<b>AC/DC</b>	Alternating/Direct current	<b>HENG</b>	Hydrogen enriched natural gas
<b>AFC</b>	Alkaline fuel cell	<b>H-Gas</b>	High calorific gas
<b>API</b>	American Petroleum Institute	<b>HHV</b>	Higher heating value
<b>B</b>	Biomass	<b>HT</b>	High temperature
<b>BM</b>	Balancing market	<b>ICE</b>	Internal combustion engine
<b>BoP</b>	Balance of plant	<b>IEA</b>	International Energy Agency
<b>BTS</b>	Base transceiver stations	<b>IER</b>	Institute of Energy Economics and the Rationale Use of Energy
<b>BTU</b>	British thermal unit (Btu)	<b>IPCC</b>	Intergovernmental Panel on Climate Change
<b>BEV</b>	Battery electric vehicle	<b>IRR</b>	Internal rate of return
<b>CAES</b>	Compressed air energy storage	<b>K</b>	Kelvin (unit of measurement for temperature)
<b>CAGR</b>	Compound annual growth rate	<b>LCA</b>	Life cycle analysis
<b>CAPEX</b>	Capital expenditure	<b>LCOE</b>	Levelized cost of electricity
<b>CCS</b>	Carbon capture & storage	<b>LCOH</b>	Levelized cost of hydrogen
<b>CHP</b>	Combined heat and power	<b>LDV</b>	Light duty vehicle
<b>CIGRE</b>	International Council on Large Electric Systems	<b>L-Gas</b>	Low calorific gas
<b>CNG</b>	Compressed natural gas	<b>LHV</b>	Lower heating value
<b>CRI</b>	Carbon Recycling International	<b>LOHC</b>	Liquid organic hydrogen carrier
<b>CUTE</b>	Clean Urban Transport for Europe	<b>LPG</b>	Liquefied petroleum gas
<b>DENA</b>	German Energy Agency	<b>MCFC</b>	Molten carbonate fuel cell
<b>DH</b>	District heating	<b>MEA</b>	Membrane electrode assembly
<b>DME</b>	Dimethyl ether	<b>MtG</b>	Methanol-to-gas
<b>DS</b>	Degree scenario	<b>NASA</b>	National Aeronautics and Space Administration
<b>DSO</b>	Distribution system operator	<b>NG</b>	Natural gas
<b>E</b>	Electricity	<b>NIP</b>	National Hydrogen and Fuel Cell Technology Innovation Program
<b>EEX</b>	European Energy Exchange	<b>NOW</b>	Nationale Organisation Wasserstoff- und Brennstoffzellen technologie
<b>EPEX</b>	European Power Exchange	<b>NPV</b>	Net present value
<b>FC</b>	Fuel cell	<b>NREL</b>	National Renewable Energy Laboratory
<b>FCEV</b>	Fuel cell electric vehicle	<b>O&amp;G</b>	Oil and gas
<b>FCHJU</b>	Fuel Cell and Hydrogen Joint Undertaking	<b>O&amp;M</b>	Operation and maintenance
<b>FIT</b>	Feed-in tariff	<b>OMEL</b>	Operador del Mercado Ibérico de Energia
<b>GHG</b>	Greenhouse gas	<b>OPEX</b>	Operating expenditure
<b>H2ICE</b>	Hydrogen internal-combustion-engine vehicle	<b>Pa</b>	Pascal (Unit of measurement for pressure)
<b>HDS</b>	Hydrodesulfurization	<b>P2G</b>	Power-to-gas

## Accronyms – (2/2)

<b>P2S</b>	Power-to-synfuel
<b>PAFC</b>	Phosphoric acid fuel cell
<b>PATH</b>	Partnership for Advancing the Transition to Hydrogen
<b>PCM</b>	Phase change material
<b>PEM</b>	Proton exchange membrane
<b>PES</b>	Primary energy source
<b>PGM</b>	Platinum group metal
<b>PHS</b>	Pumped-hydro Storage
<b>PURE</b>	Promoting Unst Renewable Energy
<b>PV</b>	Solar photovoltaic
<b>R&amp;D</b>	Research and development
<b>RCS</b>	Regulations, codes and standard
<b>RE</b>	Renewables
<b>REC</b>	Renewable energy certificate
<b>RES</b>	Renewable electricity source
<b>RMFC</b>	Reformed-methanol fuel cell
<b>SMES</b>	Super-conducting magnetic energy storage
<b>SMR</b>	Steam methane reforming
<b>SNG</b>	Synthetic natural gas
<b>SOEC</b>	Solid oxide electrolyzer cell
<b>SOFC</b>	Solid oxide fuel cell
<b>STES</b>	Seasonal thermal energy storage
<b>T&amp;P</b>	Temperature and pressure
<b>T&amp;D</b>	Transmission and distribution
<b>TCM</b>	Thermo-chemical material
<b>TCNG</b>	Turbocharged natural gas
<b>TEPS</b>	Total primary energy supply
<b>TSO</b>	Transmission system operator
<b>URFC</b>	Unitized regenerative fuel cell
<b>USDOE</b>	US Department of Energy
<b>VRB</b>	Vanadium redox batteries
<b>WVTA</b>	Whole vehicle type approval
<b>ZES</b>	Zentrum für Energieforschung Stuttgart (Energy Research Center, Stuttgart)

# List of chemical formulae

<b>2CH<sub>3</sub>OH</b>	Methanol	<b>PtCo</b>	Platinum cobalt
<b>C</b>	Carbon	<b>PtN</b>	Platinum nitride
<b>C<sub>6</sub>(H<sub>2</sub>O)<sub>5</sub></b>	Cellulose	<b>SO<sub>2</sub></b>	Sulfur dioxide
<b>C<sub>2</sub>F<sub>4</sub></b>	Nafion	<b>Ru</b>	Ruthenium
<b>CH<sub>3</sub>OCH<sub>3</sub></b>	Dimethyl ether	<b>Zn Br</b>	Zinc Bromine
<b>CH<sub>4</sub></b>	Methane		
<b>CO</b>	Carbon monoxide		
<b>CO<sub>2</sub></b>	Carbon dioxide		
<b>H</b>	Hydrogen		
<b>H<sub>2</sub>O</b>	Water		
<b>H<sub>2</sub>S</b>	Hydrogen sulfide		
<b>HC</b>	Hydrocarbon		
<b>HCOOH</b>	Formic acid		
<b>KOH</b>	Potassium hydroxide		
<b>Li-ion</b>	Lithium-ion		
<b>Mg</b>	Magnesium		
<b>MgH</b>	Magnesium hydride		
<b>N<sub>2</sub></b>	Nitrogen		
<b>NaBH<sub>4</sub></b>	Sodium borohydride		
<b>NaBO<sub>2</sub></b>	Sodium borate		
<b>NaNO<sub>3</sub></b>	Sodium nitrate		
<b>NaS</b>	Sodium sulfur		
<b>NH<sub>3</sub></b>	Ammonia		
<b>Ni</b>	Nickel		
<b>NiCd</b>	Nickel cadmium		
<b>NiMH</b>	Nickel metal hydride		
<b>No</b>	Nitric oxide		
<b>NO<sub>x</sub></b>	Nitrogen oxides		
<b>O<sub>2</sub></b>	Oxygen		
<b>OH</b>	Hydroxide		
<b>Pt</b>	Platinum		

# List of figures – Section 1

1. IEA CO2 emissions and energy supply evolution, plus development pathways
2. The global energy system 2010
3. Wind & solar PV technologies lifting off (estimates for 2012-2017)
4. Key technologies to reduce CO2 emissions in the power sector in the 2DS, relative to the 4DS
5. Wind & PV intermittency: 1st-7th of January 2011, northern Germany
6. Wind resources and densely populated hubs in the US
7. Daily load curve on 5th January 2013 in France
8. Weekly load curve in winter vs. summer in northern Germany
9. Categorization of ancillary services used to ensure grid stability
10. Price and load duration curves, Sweden, 2011
11. Wind & solar photovoltaic generation vs. demand in northern Germany
12. Capacity credit of wind in 2035
13. Illustrative impact of growing variable renewable penetration on load duration curve & residual load duration curve
14. Flexibility resources and flexibility needs in the power system
15. Energy storage technologies categorizations
16. Energy storage in the US power sector in 2011
17. Electricity energy storage installed capacities by technology
18. Storage systems schematic representation
19. Applications depending on discharge time and capacity
20. Applications depending on grid location
21. Irish market projections for 2030 based on weather patterns from January 2000
22. Electricity storage application requirements
23. Electricity storage technologies' features
24. German residual basic load for 2050, based on 2009 data
25. Hydrogen production by technology
26. Hydrogen consumption by end use
27. H2 - history of use
28. Hydrogen-based storage system - schematic representation
29. Comparison between hydrogen and conventional storage
30. Hydrogen-based energy transport routes
31. Energy carrier distribution by end-use, 2009 and 2050 (IEA's 2DS scenario)
32. Simplified value chain of hydrogen-based energy storage solutions

## List of figures – Section 2 (1/5)

33. History of water electrolysis
34. Schematic principle of a water electrolysis cell
35. Cell efficiency and H<sub>2</sub> production rate as a function of the cell voltage at ambient conditions (illustrative figures)
36. Schematic of electrolyzer stack
37. Schematic of an electrolyzer plant
38. Thermodynamic performances (voltage vs. current density), at different operating pressures and temperatures for a given cell
39. Qualitative effects of operating conditions on electrolyzer performance
40. Typical thermodynamic performances of electrolyzers
41. Comparative performance of alkaline, proton exchange membrane and solid oxide electrolyzer cells
42. Alkaline cell schematic (left) and real 2.7 MWch stack (right)
43. Alkaline electrolyzer characteristics
44. PEM cell schematic (left) and real 1 kW PEM stack (right)
45. Proton exchange membrane electrolyzer characteristics
46. SOEC cell schematic and principle
47. Solid oxide electrolyzer cell characteristics
48. Electrochemical performance of electrolyzer systems
49. Alkaline cell design R&D
50. PEM cell design R&D
51. Evolution of PEM stack and system costs
52. Comparative advantages and drawbacks of electrolyzer types
53. Levelized cost of hydrogen's impacting factors
54. LCOH breakdown of an electrolyzer plant as a function of its annual load factor, for a fixed electricity price of \$65 /MWh
55. Range of LCOH for an electrolyzer utilized at full load, without compression, storage or delivery, as a function of feedstock electricity price
56. Illustrative electricity spot market price over one year
57. Resulting LCOH as a function of the annual load factor
58. Electricity spot price duration curves (France & Germany, 2012)
59. LCOH of a grid-connected electrolysis plant (Germany, 2012)
60. Hydrogen storage and transport act as buffers between production and end-uses
61. Hydrogen 'packaging' between production and end-use: conditioning, storage and transport options
62. Comparative table of hydrogen storage technical characteristics
63. Levelized added cost of hydrogen storage – literature's ranges
64. Energy lost in processing and storage
65. Optimal hydrogen storage technology as a function of the desired cycling rate
66. Phase diagram of hydrogen

## List of figures – Section 2 (2/5)

67. Levelized cost of storage against storage duration with fixed production rate
68. Levelized cost of storage against storage duration with fixed production rate
69. Illustration of a salt cavern
70. Existing H<sub>2</sub>-Caverns in salt domes
71. Principle of metal hydride hydrogen storage (left), and McPhy's metal hydride H<sub>2</sub> storage system (right)
72. Levelized cost of storage depending on the size of the liquefaction plant
73. Single-walled carbon nanotubes
74. Clathrate hydrates
75. Metal-organic frameworks
76. Salt formations
77. Potential locations for salt caverns in the US
78. Qualitative comparison of the three H<sub>2</sub> underground storage options
79. Levelized cost of hydrogen transported
80. Lowest-cost H<sub>2</sub> transport option according to distance and throughput
81. Levelized cost of compressed hydrogen transported by road trailers
82. Key facts about hydrogen transport in compressed tanks on road trailers
83. Levelized cost of liquid hydrogen transported by road trailers
84. Key figures for hydrogen transport in cryogenic tanks on road trailers
85. Levelized cost of hydrogen transported by pipeline
86. Key figures for pipeline transport of hydrogen
87. Levelized cost of hydrogen delivery (processing, storage and transport) to 50 end-use sites of 1 MWch each - four different layouts compared.
88. Energy forms in the two re-electrifications pathways
89. Power range and applications of hydrogen re-electrification
90. Comparison table between fuel cells and hydrogen turbines
91. Losses along the stored hydrogen re-electrification value chain
92. Example of a solid oxide fuel cell plant with CHP and combined-cycle
93. Timeline for the development of fuel cells
94. Annual sales of fuel cells by usage
95. Annual sales of fuel cells by type
96. Annual sales of fuel cells by region
97. Schematic diagram of a proton exchange membrane fuel cell
98. Schematic of a fuel cell plant
99. Typical fuel cell current density, operating voltage, efficiency and power density curve
100. Fuel cell efficiency, operating voltage and power density according to the temperature, for different current densities

## List of figures – Section 2 (3/5)

101. Difference in the fuel cell operating voltage at different pressures
102. Comparison of hydrogen storage characteristics
103. Schematic of a PEMFC (left) and stack interconnection (right)
104. Key figures for stationary PEMFC system
105. Schematic of SOFC cell (left) and stack (right)
106. Key figures for a SOFC with CHP system
107. Schema of a hydrogen turbine (left) and illustration of a hydrogen turbine (right)
108. Enel's Fusina hydrogen pilot power plant
109. Pathways between energy carriers
110. Pathways between energy grids
111. Integrated power-to-gas pilot projects passed final investment decision, as of May 2013
112. Principle of hydrogen blending into natural gas grid
113. Metal cracking resulting from hydrogen embrittlement
114. Typical natural gas network (French case)
115. Effects of increasing hydrogen content on a 10 GW gas pipeline
116. Pipeline hydraulics explained
117. Wobbe index of hydrogen enriched natural gas
118. Natural gas vs. hydrogen flame combustion
119. Limit of H<sub>2</sub> blending along the natural gas infrastructure
120. Typical biomethane connection installation
121. Annual gas demand pattern in a medium-pressure (16 bar) distribution pipeline in the French GrDF network
122. Maximal continuous biomethane injection authorized in France's regional transport network, and estimated equivalent possible H<sub>2</sub> injection rate
123. Intra-day fluctuation of the French "H-gas" grid during a typical winter weekday with constant gas supply equaling daily average demand
124. Order of magnitude of German HENG potential at 5vol.% blending
125. Power-to-methane process
126. Mass flow chart of a 1 MWe power-to-methane process with pure CO<sub>2</sub> feed
127. Energy flow chart of a 1 MWe power-to-methane process with pure CO<sub>2</sub> feed scrubbed from air
128. Mass flow chart of electrolysis-assisted biomethane plant
129. Energy flow chart of electrolysis-assisted biomethane plant
130. Electrolysis-assisted biomass plant layouts
131. Wind turbines near a new biogas plant in the German state of Lower Saxony
132. Land used for corn cultivation in Germany
133. Coal power plant with integrated power-to-methane plant
134. Physical flows of a coal oxy-combustion plant coupled with a P2G plant recycling 100% of CO<sub>2</sub> emitted

## List of figures – Section 2 (4/5)

135. Methanation methods compared
136. Thermochemical methanation reactor with surface catalysis
137. Sabatier reaction conversion yield under atmospheric conditions, after the gases pass through the reactor
138. *M. smithii* methanogenic archaea
139. Electrochaea's 250 kW biological methanation reactor for the Foulum project (Danish Biogas Demonstration project)
140. Targeted capital-cost reductions of power-to-methane plant
141. Levelized costs of SNG from power-to-methane plant in 2020
142. Power-to-synfuels pathways for H-C-O synfuels production
143. C-H-O model
144. Energy density comparison of transportation fuels
145. Chemical composition of some C-H-O synfuels
146. CO hydrogenation reactor for methanol synthesis
147. George Olah renewable methanol plant, Svartsengi, Iceland
148. Liquid fuel prices per energy content
149. SASOL-Chevron Fischer-Tropsch reactor
150. Synthetic liquid hydrocarbon pathways
151. SOEC in co-electrolysis mode
152. Thermodynamics of SOEC in co-electrolysis mode:
153. Direct synfuel SOEC stack
154. Direct methanol SOEC coupled with first generation bioethanol plant for land use optimization
155. The role of hydrogen in mobility
156. Timeline for hydrogen in the transportation sector
157. Public R&D in fuel cells, 2000-2010
158. Operational number of H2 fueling stations, as of April 2013
159. From left to right, Honda FCX clarity (FCEV), BMW Hydrogen 7 (H2ICE) and HCNG dispenser fuelling a HCNG Bus
160. Well-to-wheel energy efficiency & lifecycle CO2 emissions comparison for different type of engines
161. Comparison of weight and volume of energy storage tanks for a 500 km range personal vehicle
162. Hydrogen-filled hollow glass microsphere
163. Basic circuits in a fuel-cell electric vehicle
164. Hyundai ix35 fuel-cell electric vehicle
165. Mobile proton exchange membrane lifetime
166. Mobile fuel cell system costs: target at a production rate of 500,000 units per year
167. Schematic of the PEMFC cell and its membrane electrode assembly
168. Proton exchange membrane platinum-based catalyst

## List of figures – Section 2 (5/5)

169. Summary of fuel cell electric buses performance compared to U.S. Department of Energy & Federal Transit Administration targets
170. BMW Hydrogen 7, able to run on either liquid H<sub>2</sub> or gasoline with the same internal combustion engine
171. Main R&D axis for H<sub>2</sub>ICE
172. Comparative performances of different blends when running the motor at constant full load
173. Annual worldwide hydrogen consumption
174. Estimated US hydrogen production capacity
175. Schematic of refining operations
176. Typical hydrogen net consumption by refining process
177. Catalytic reforming illustration
178. Global sulfur limits & hydrogen need for differing levels of removal
179. Average hydrogen-to-carbon ratio (H/C) of crudes
180. Distribution of oil fractions and average H/C ratio
181. Net hydrogen balance by typical refining schemes
182. Using wind energy to upgrade bitumen from Alberta's oil sands (model from B. Olateju and A. Kumar)
183. Ammonia - Consumption by end use
184. Ammonia - Top 10 producing countries
185. Feedstock distribution for ammonia production
186. Greenfield fertilizer plant of Sorfert Algeria built by Orascom Construction Group
187. Simplified integrated steam methane reforming flow diagram
188. Freedom Fertilizer wind-to-ammonia process
189. Proton Venture mini wind-to-hydrogen plant design
190. Non-refueling station project capacity per year
191. Non-refueling station project capacity per end-product
192. Realized electrolytic H<sub>2</sub> fueling stations
193. Realized and planned electrolytic H<sub>2</sub> fueling station
194. Schematic layouts of integrated projects
195. Key parameters influencing choice of plant configuration and determining project economics
196. Economics of two stationary storage systems of similar round-trip efficiency, and similar specific capital costs of components
197. Order of magnitude of achievable efficiencies and levelized costs of synfuels for various integrated projects, operated continuously from the German power grid
198. Enertrag Hybridkraftwerk project layout
199. Enertrag Hybridkraftwerk plant
200. Thüga Group power-to-gas electrolyzer plant (left) and layout (right)
201. Audi e-gas pilot project

## List of figures – Section 3 (1/2)

- 202. End-markets of electrolytic hydrogen
- 203. Examples of direct revenue streams from the conversion of intermittent-source electricity into hydrogen
- 204. End-market prices for hydrogen feedstock in Germany vs. natural gas
- 205. Illustration of electrolysis operation as control power
- 206. Operating characteristics for hydrogen production with and without participation in the balancing market
- 207. The role of the hydrogen energy carrier in the Ecoland project, Isle of Wight (UK)
- 208. Simplified stakeholder interactions in power-to-gas pathways in Germany
- 209. Illustration of energy system layout from single-source single-product to multiple-source multiple-product
- 210. Power system and application factors influencing hydrogen business cases
- 211. Project layout
- 212. Intermittent power penetration rate
- 213. Hourly variability in 2012
- 214. Spot market price range and mean value
- 215. LCOH for continuous and fluctuating operations
- 216. LCOH and load factor with balancing market strategies
- 217. Sensitivity analysis results, for the scenario spot cont. & BM
- 218. Spot market and balancing market flowchart
- 219. Price/volume curve for each hourly period
- 220. Project layout
- 221. Estimated lowest obtainable average spot price for purchasing power during a given number of hours in Denmark
- 222. Levelized cost of hydrogen fed into the gas grid as a function of electrolyzer operating hours per year for different wind penetrations
- 223. Average contribution of non-wind power sources as a function of electrolyzer operating hours for four different wind-penetration scenarios
- 224. Levelized cost of injected hydrogen and feed-in tariffs
- 225. Schematic of renewable energy certificates
- 226. Project layout
- 227. Capital costs breakdown (Total = \$675 million)
- 228. Breakdown of the levelized cost of delivered hydrogen
- 229. Fuel-cycle greenhouse gas emissions
- 230. Project layout
- 231. Capital cost breakdown
- 232. Breakdown of annualized cost of ownership in the base case
- 233. Price duration curve of spot electricity price in 2011 in Sweden, and break-even electricity price as a function of operating hours
- 234. Simplified project layouts
- 235. Levelized cost of methanol as a function of the price of electricity

## List of figures – Section 3 (2/2)

- 236. Breakdown of levelized cost of methanol for electricity price at €40 /MWh (base case)
- 237. Lessons learned from operating pilot projects of hydrogen-based back-up power systems for remote or island locations
- 238. Simplified project layouts
- 239. Variation of critical fuel cost with seasonal solar energy difference (schematic)
- 240. Variation of critical fuel cost required for PV/H2 system to compete with PV/diesel system (2011, for various countries)
- 241. Variation of critical fuel cost in India for various H2-system configurations (2015)
- 242. Diesel engine powering a telecoms tower in India
- 243. PV-powered telecoms tower in India
- 244. Layout of H2-based storage system
- 245. Evolution of H2 stored in a week
- 246. Range of levelized cost of output electricity from storage
- 247. Electricity price sensitivity vs. round-trip storage efficiency
- 248. Installed capacity in four scenarios, excluding storage
- 249. Annual electricity generation
- 250. Typical annual demand and residual load pattern
- 251. Forecasted effect of high renewable penetration the German electricity system
- 252. Levelized cost of electricity output for monthly storage systems
- 253. Potential for electricity storage system in Germany

# List of figures – Section 4 & Section 5

## SECTION 4

- 254. Summary of environmental impacts of hydrogen-based storage of intermittent renewable electricity
- 255. Comparative life-cycle carbon emissions (left) and acidification potential (right) of hydrogen-production technologies
- 256. Atmospheric reactions resulting from hydrogen release
- 257. Illustrative land-use comparison to produce an average of 1 GW of renewable electricity
- 258. Examples of land requirements of technologies
- 259. Net water consumption<sup>1</sup>, electrolysis vs. power plants
- 260. Flow chart of a typical commercial electrolyzer Electrogenics model<sup>2</sup>
- 261. Summary of safety issues associated with hydrogen use
- 262. Schematic of the process of hydrogen embrittlement through absorption
- 263. Illustration of different types of steel damage
- 264. E.ON's Falkenhagen power-to-gas pilot, Germany
- 265. Anatomy of a salt dome
- 266. Heterogeneity of gases, resulting from bacterial methanogenesis
- 267. Selective physical properties and risks in air of hydrogen, methane and gasoline
- 268. Hydrogen sensors and their properties
- 269. Example of a hydrogen fiber-optic sensor (left), and colorimetric indicator (right), showing black exposed coating
- 270. European Union Initiative Group – RCS Action plan
- 271. Photograph of the Hindenburg incident
- 272. Why Vattenfall's CCS project was cancelled?
- 273. Steps to a socially accepted technology system
- 274. Advertising a hydrogen bus

## SECTION 5

- 275. Illustrative role of electrolytic hydrogen as a bridge between electron and molecular-based energy
- 276. Simplified matrix of key energy-system factors, organized by hydrogen-solutions – illustrative only
- 277. Illustrative roadmap for hydrogen-based energy storage solutions in Europe
- 278. Technological maturity curve of hydrogen-related technologies
- 279. Commercial maturity curve of integrated hydrogen projects
- 280. Examples of technology-push and market-pull policy instruments from IEA ETP 2012
- 281. Simplified scheme for renewable-certificate exchange within an integrated energy market<sup>3</sup>

## List of boxes

- Box 1**          Energy system
- Box 2**          Energy storage technologies
- Box 3**          Hydrogen basics
- Box 4**          Energy units
- Box 5**          Suitable caverns for underground hydrogen storage
- Box 6**          Fischer-Tropsch vs. methanol-to-gasoline processes for liquid synfuel production
- Box 7**          Refining operations
- Box 8**          Ammonia Basics
- Box 9**          Electricity markets
- Box 10**        Renewable energy certificates

## Picture credits

- Slide 14:** Wind turbines from the West Wind Project, New Zealand, Siemens
- Slide 17:** Solar photovoltaic panel
- Slide 22:** Bizkaia Energia 755 MW combined cycle gas turbine, Spain, ESB International
- Slide 28:** Seneca 435 MW pumped hydro storage plant in Pennsylvania, USA, FirstEnergy
- Slide 40:** Hydrogen storage tank, Linde
- Slide 45:** 2 MW electrolysis plant from E.ON's Falkenhagen power-to-gas pilot plant (H<sub>2</sub> injection into the local gas grid), Germany, Hydrogenics
- Slide 46:** HFuel electrolysis unit displayed at the 4th World Hydrogen Technologies Conference, United Kingdom, ITM Power
- Slide 64:** Hydrogen storage & refueling facility in Whistler, Canada, Air Liquide
- Slide 84:** Fusina 16 MW Hydrogen pilot power plant, Italy, Enel
- Slide 101:** Audi 6.3 MWe e-gas pilot project (methanation) in Werlthe, Germany, Audi
- Slide 125:** Bio-Methanol plant at Industriepark Schwarze Pumpe, Germany, Deutsche BioMethanol
- Slide 136:** Hyundai Tucson fuel cell electric vehicle at Shell hydrogen refueling dispenser in California, United States, Hyundai Motor
- Slide 152:** Sorfert steam methane reforming fertilizer plant (2,200 t/d ammonia and 3,400 t/d urea), Algeria, Orascom Construction Group
- Slide 152:** 1 MW Power-to-Gas System from Hydrogenics located in Grapzow 140 MW Wind Park, Germany, Hydrogenics
- Slide 176:** Hybrid power plant including 500 kW electrolyzer, Germany, Enertrag
- Slide 177:** CUTE hydrogen station to refuel fuel cell buses in Hamburg, Germany, Vattenfall
- Slide 188:** Mobile tower powered by solar photovoltaic cells, India, Vihaan Network Limited
- Slide 226:** The Earth as seen from space
- Slide 229:** Digester tank from the Werlthe biogas plant, Germany, EWE Biogas GmbH & Co.
- Slide 236:** Chemical & hazardous materials sign legend
- Slide 246:** Protests against a CO<sub>2</sub> carbon capture and storage project, Germany
- Slide 250:** MYRTE energy-storage platform including a 560 kWc solar field, and integrated hydrogen module, France, Areva
- Slide 263:** San Jose 500 kW fuel cells eBay installation, US, Bloom Energy

The A.T. Kearney Energy Transition Institute is a nonprofit organization. It provides leading insights on global trends in energy transition, technologies, and strategic implications for private sector businesses and public sector institutions. The Institute is dedicated to combining objective technological insights with economical perspectives to define the consequences and opportunities for decision makers in a rapidly changing energy landscape. The independence of the Institute fosters unbiased primary insights and the ability to co-create new ideas with interested sponsors and relevant stakeholders.

For further information about the A.T. Kearney Energy Transition Institute and possible ways of collaboration, please visit [www.energy-transition-institute.com](http://www.energy-transition-institute.com), or contact us at [contact@energy-transition-institute.com](mailto:contact@energy-transition-institute.com).

Permission is hereby granted to reproduce and distribute copies of this work for personal or nonprofit educational purposes. Any copy or extract has to refer to the copyright of the A.T. Kearney Energy Transition Institute.